

STAR WARS

Black Ice

An Adventure for use with *Star Wars: The Roleplaying Game*

PLUS
StarWorriors
MINI-CAMPAIGN

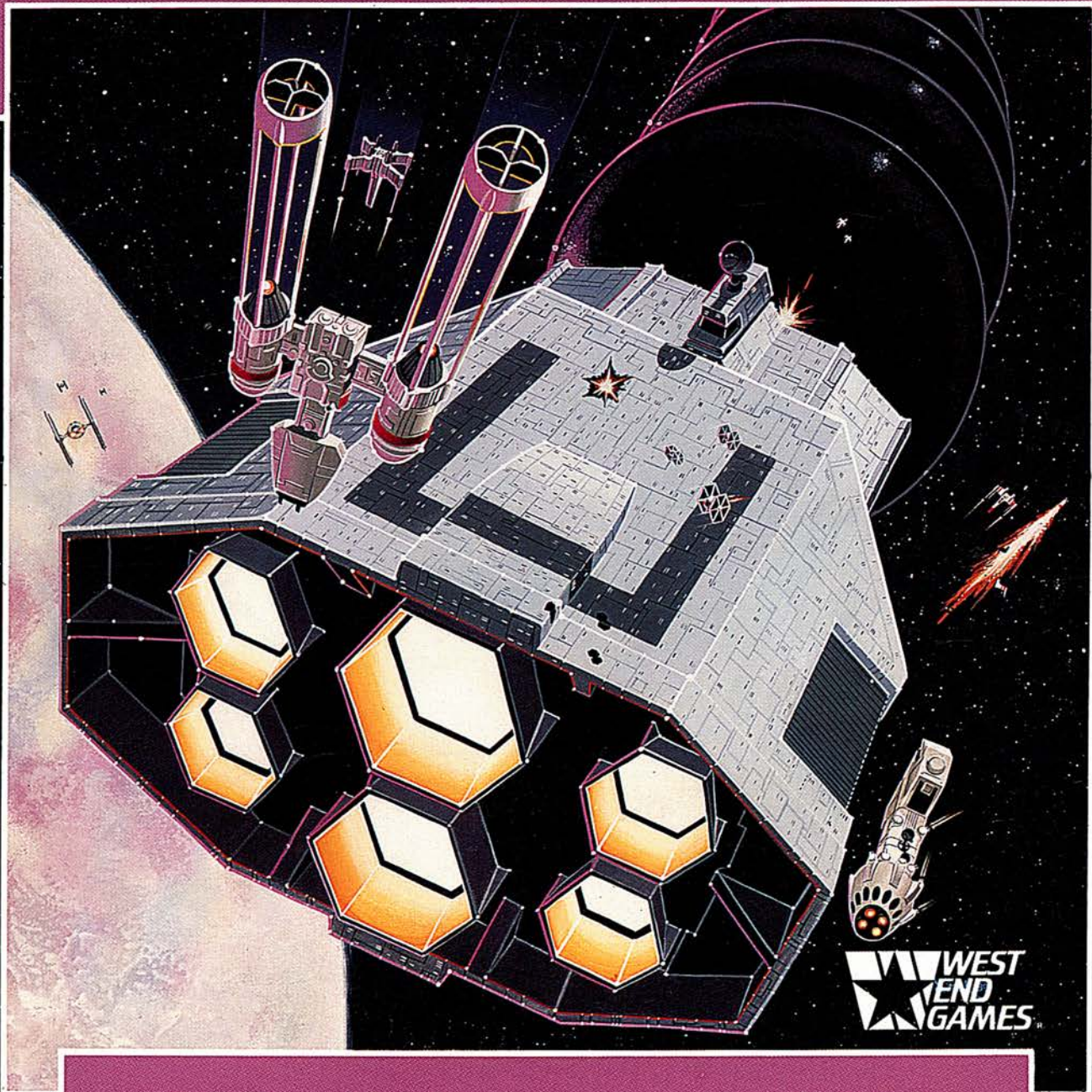

WEST
END
GAMES

Rebel heroes lead the attack against an Imperial Fleet!
The prize: the Empire's biggest cargo
vessel — the *Black Ice*!

STAR WARS®

Black Ice

by Paul Murphy and Bill Slavicsek



Development and Editing: **Bill Slavicsek**
Graphics: **Jacqueline M. Evans** • Cover Art: **David Deitrick**
Interior Art: **Bob Dvorak** • Maps: **Rosaria J. Baldari**

Publisher: **Daniel Scott Palter** • Associate Publisher: **Richard Hawran** • Assistant Publisher: **Denise D. Palter**
Editorial Director: **Bill Slavicsek** • Associate Editors: **Greg Gorden, Douglas Kaufman, Paul Murphy**
Editors: **Jonatha Ariadne Caspian, Michael Stern, C. J. Tramontana** • Art Director: **Stephen Crane**
Graphic Artists: **Rosaria J. Baldari, Bernadette G. Cahill, Jacqueline M. Evans, Cathleen Hunter, Sharon Wyckoff**
Production Manager: **Steve Porpora** • Sales Director: **Martin Wixted** • Sales Manager: **Fitzroy Bonterre**
Sales Assistants: **Tony DeCosmo, Maria Kammeier** • Special Projects Manager: **Ronald Seiden** • Treasurer: **Janet Riccio**



RD3 Box 2345
Honesdale, PA 18431

I ntroduction

This adventure is for use with *Star Wars: The Roleplaying Game*. It is designed for up to six player characters and a gamemaster. If you want to run a player character, stop reading now. The information in this book is for the gamemaster only; he should read it entirely before play.

In this Adventure ...

... Rebels agents take on a mission that builds from a simple job — to infiltrate an Imperial tech outpost and steal data on an Imperial replenishment fleet — and grows increasingly more impossible. The Alliance desperately needs fuel to power its own fleet, and the information that the Rebels acquire points them to a great source — the container train *Black Ice*.

Now all the Rebels have to do is survive a head-on assault with the vessel, break in, and take over the ship. But complications arise, as they always do, and the Rebels must repel an Imperial attack on Alliance Sector HQ before the Empire captures or destroys the important Rebel base.

Adventure Materials

In addition to the adventure, the pullout section (including script, character templates, data handouts, maps of the tech outpost and *Black Ice*) and the *Star Warriors* counter strip, you also need *Star Wars: The Roleplaying Game*, *The Star Wars Rules Companion*, pencils, paper, and lots of six-sided dice.

The Star Wars Sourcebook, *Imperial Sourcebook*, *Star Warriors* starfighter combat game, and *Star Wars* miniatures sets are recommended but are not necessary for play.

The Adventure

You cannot fight a war without supplies. That is the hard fact that the Rebel Alliance is learning every day. Ships, weapons, ammo, clothing, food, fuel, and a host of incidental necessities must be procured constantly to stave off the better-equipped Empire.

The Alliance survives on the generosity of unknown benefactors, on the ingenuity of its members, and on the booty from countless raids against Imperial ships. But it is getting harder to catch these ships unaware and unprotected.

That's where the Rebel heroes come in.

They are sent to a nearby Imperial tech outpost to procure information concerning Imperial replenishment fleet activity. If they can discover a hole in Imperial security, a time when the lightly-armed cargo transports are unprotected, then a raid will have a higher chance of success.

Eventually, the Rebels board the container train *Black Ice*, wherein they are forced to deal with some unexpected developments. Then, when they think they have safely moved the vessel to Sector HQ, the last surprise is revealed: the Empire has followed them back to their lair!

Can the Rebels defeat Imperial soldiers, zero G stormtroopers, and a fully-armed torpedo sphere before the base is demolished? Let's find out ...

The Main NPCs

QT-7: This computer access Droid helps the Rebels break into the computer files at the tech outpost in episode one, assists them in cracking the coded data in episode two, and should be around to communicate with *Black Ice* in episodes three and six. With its carrying handle, QT-7 looks like a high-tech suitcase. Its face is covered with blinking lights, screens of various sizes, and input and output jacks. It is cheerful, friendly, and enjoys a good game of sabacc.

Major Lawra Mers: Mers has quickly risen to the post of field mission commander for the Alliance. She coordinates dozens of Rebel strike teams and agent groups at a time, keeping these small but effective forces moving from assignment to assignment. The Rebel heroes in this adventure have been assigned to Major Mers because of their past successes and because Mers specifically requested them after viewing Alliance High Command holoreports on the group. She appears in episodes two, five and six.

Chief Engineer Skolos: Skolos is a hard, dedicated man who cherishes his beloved ship, *Black Ice*. While he isn't extremely pro-Empire, he sees the Rebels as pirates who have dared invade his ship. He decides to battle the "pirates" and win back *Black Ice* by using what he knows best — he turns the ship itself against the Rebels, using every automated threat to push back the invaders. He confronts the Rebels in episode four.

E pisode One Mission: Impossible

Summary

As the adventure opens, the Rebel heroes are inside an Imperial Intelligence Analysis Bureau, Technical Branch Outpost (tech post, for short). They are using a sophisticated, but quirky, computer access Droid named QT-7 to tap into the outpost's computer system. They are searching for information concerning Imperial replenishment fleet activity. The first tap yields them the information they seek — but it is in code!

The Rebels must work their way deeper into the post to tap the computers in the high security section to find the key to breaking the code. Then they must slip (or fight their way) out of the post and across several hundred kilometers of unpleasant swamp to get the information safely back to Sector HQ.

R ead Aloud

A long time ago, in a galaxy far, far away ...

In the bitter struggle against the Empire, not all battles are fought with blasters.

Sometimes it is more useful to know what the enemy is up to than it is to destroy him. The right piece of information, discovered at the right time, is sometimes more valuable than a hundred starfighters.

But sometimes not.

Sometimes knowing too much is a bad thing. Sometimes it just gets you into trouble. The espionage game is like that — as a group of Alliance Counterintelligence Specialists (spies, that is), in the middle of a dangerous infiltration mission, are about to discover ...

Start the Adventure

Locate the script in the pullout section. Assign each player a part, from "1st" through "6th" Rebel. Assign multiple parts as necessary, if you have fewer than six players.

The script starts the player characters right in the middle of a situation and when it is finished being read, the adventure is underway!

First Things First

The players are probably going to have a number of questions — "where are we?" or "what's our cover story?" or "how come we don't have any guns?" Don't give them a chance to worry too much about these admittedly important questions right now. They can figure it all out after they deal with the immediate problem. Read:

The technician is gaping in shock at QT-7. He's about to speak — if you want to do something about it, it had better be quick.

Give each of the Rebels five seconds to announce an action, reminding them that they are completely unarmed. If a Rebel hesitates when his turn comes up, skip him and immediately go on to another. Once all have announced an action (or have taken too long thinking one up), read:

The technician says, with awe in his voice, "Wow! That's a QueTee model, isn't it? Where'd you get it? Can I look at it?"

After hearing this, some of the Rebels may wish to reconsider their actions, particularly if they were homicidal in nature. Allow these Rebels to make Easy *Dexterity* rolls, success indicating that the Rebel smoothly converted his punch into a friendly slap on the back, missed with his kick, or the like, and failure indicating that the action was too far progressed to stop before semi-violent physical contact took place.

If the technician was hit but wasn't actually wounded, it takes a Moderate *con* roll to convince him that the attack was an accident.

If the tech was wounded, he's going to begin making a lot of noise real soon. The Rebels have one round to either finish him off or gag him and lock him in a closet somewhere. If they fail, immediately go to "The Chase."

Once this incident is resolved or there is a break in the action, read the sidebar entitled "How Did the Rebels Get into this Mess?"

How Did the Rebels Get into this Mess?

Read the following to the players, or paraphrase it, at a suitable lull in the action:

You are currently assigned as counterintelligence agents — that is, spies — to Mortex Sector HQ. Your commanding officer, Major Lawra Mers, volunteered you for a special mission to infiltrate an Imperial Intelligence, Technical Services Branch outpost located deep in the swamps on a planet called Lotide. Your mission is to access the outpost's computers for information concerning the Imperial replenishment fleet, with a secondary assignment to learn all you can about research at the outpost.

You were equipped with forged identitags, describing you as a group of scientists newly posted to the base, plus regulation scientist-style lab coats, pocket computers, and other suitable gear. You had to leave your blasters and other weapons behind, as they would set off alarms and blow your cover.

One of you was given charge of QT-7, a small, rectangular computer access Droid with simulated banthaskin exterior and a handle on top. With sensor receptors and computer access port retracted, QT-7 does a credible imitation of a suitcase — if he can remember to keep his mouth shut.

You entered the planet openly, taking low passage on a tramp freighter. Once on the planet, you arranged repulsorlift transport from the spaceport to the outpost.

The outpost is a large, dismal building in the middle of a large, dismal swamp several hundred kilometers from the city. Entering the building, you presented your credentials and then passed through an elaborate security scan, which made you happy that you had left your weapons off-planet. QT-7 was given a cursory glance but nothing more.

A different security guard escorted you upstairs to the chief scientist's office, telling you that Dr. Benkin would be along momentarily. He ordered you not to touch anything and then left. Ignoring his instructions, you accessed the chief's computer terminal.

- **What's Our Cover?** You are scientists transferred from Dakot Seven (a small, academically-oriented planet on the other side of the sector) because of political unreliability, or incompetence, or both. You have been thoroughly briefed on Dakot Seven and the tech post there (+1D to *con* rolls when answering questions about background).

- **How Do We Get Off this Planet, Anyway?** All of the scientists go back to the city in a repulsorlift transport at the end of the work day. Once in the city, you have the name and address of a Rebel sympathizer who will get you off-planet, plus an alternate contact, if the first one fails.

- **What Do They Do Here?** That's what you're here to find out.

- **Other Questions?** You're on your own.

About this Information ...

After the Rebels have finished with the technician (or sometime during the ensuing chase scene if they didn't silence him quickly enough), QT-7 informs them about one tiny problem. Read:

"Hey, guys," QT-7 chirps cheerfully, "you know that information I retrieved? There's a slight problem that you should probably know about." (Pause so that the Rebels can ask the obvious questions.) **"I downloaded all of the files pertaining to the replenishment fleet's flight plan and ... well, see for yourself."**

With that, QT-7 flashes information across one of his many display screens.

Give the players the handout titled "QT-7's Display Screen." It shows the pertinent selection from the data files, but it's all in code! QT-7

cannot break the code (he's tried), but he has found out where the key is located.

"Access to the code key is blocked from this level. In order to get at it I have to plug into one of the high-clearance security computers."

QT-7 calls up a map of the outpost (show the players the "Tech Post Floorplans" from the pull-out) and highlights rooms 30, 32 and 33.

Running the Rest of this Episode

Essentially, the rest of this episode is a journey through the outpost. The post is occupied by incompetent scientists, playing with forces they barely comprehend, and a number of disgusted, low-morale Intelligence Security Personnel. There is danger here, but not a lot of it. Though the

Rebels may end up in a fight, chase, or both, unless things go very wrong they should emerge unscathed. Try to keep the tone of the episode light-hearted. (Things *will* get a good deal tenser later in the adventure, believe us!)

The Rebels have only a few specific things they must accomplish: they must recover the information necessary to break the code on the fleet data; they must find out as much as possible about what research is being pursued at the tech post; they must safely get the fleet data back to Sector HQ.

The remainder of the episode is divided into three parts. The first part, "The Outpost and Denizens," describes the outpost and the personnel within it. The second part, "Events," describes some things which may happen while the Rebels are wandering about. The third part, "The Chase," gives you some tips on running a battle in and around the outpost, as well as describing the Rebels' escape through the swamp.

Outpost Characters

There are three types of characters in the outpost — bureaucrats, scientists, and security guards. In general, they are standard human specialists, with 2D in all attributes and with +1D to +4D training in up to four skills, as listed below. Feel free to alter individuals for variety.

Bureaucrats: The tech post is not a particularly exciting or rewarding place to work for bureaucrats: it's in the middle of a swamp, there's little or no room for advancement, the scientists are weird, and it doesn't seem as if anybody in the galaxy knows (or cares) what goes on here. Thus, the bureaucrats are more than a little demoralized, surly, and indifferent. *Skills:* *bureaucracy* 3D+2.

Scientists: In general, the scientists like it here: they are well-funded, and nobody seems to care whether they produce anything or not. Most of them were sent here because they were too quirky, too odd or, in some cases, too brilliant to fit in at the standard, highly-regulated Imperial research facilities. *Skills:* Biologists: *alien races, medicine*, 2D-5D; Computer programmers: *technology, computer programming and repair*, 3D-6D; Physicists: *blaster, dodge, grenade, heavy weapons*, 2D+2; *technology* 3D-5D; Technicians: *computer repair, weapons repair, Droid repair, repulsorlift repair* 3D-6D.

Security Guards: Most of the security guards at the outpost are natives of the planet — police, military men, and the like — specifically recruited by Intelligence Internal Security for this post. They don't have the training of standard IntSec

career officers, though Captain Hawra has done a credible job of whipping them into shape.

- **Standard Outpost Trooper:** A youngish man, none too thrilled about being posted to the middle of a swamp, but quite happy about the pay.

DEX 2D, blaster 3D+1, dodge 2D+2; KNO 2D; MEC 2D, repulsorlift operation 3D+1; PER 2D, search 2D+1; STR 2D, brawling 3D+2; TEC 2D, security 2D+2.

- **Lieutenant Pora, Second in Command:** A cold, calculating, absolutely dedicated killer. Actually an IntSec captain, Pora is here undercover, investigating charges of corruption against Captain Hawra. If they are substantiated, Pora won't even bother with a trial — Hawra will simply be found one day, floating in the swamp.

DEX 2D+1, blaster 3D+2, dodge 3D, melee 3D; KNO 2D+2, bureaucracy 3D+2, streetwise 4D; MEC 3D, repulsorlift operation 4D; PER 3D+1, command 4D+1, con 3D+2, search 4D; STR 3D+1, brawling 4D; TEC 3D+1, security 5D.

- **Captain Hawra, Commander, Security:** A cheerful, outgoing man, Hawra rose to his present position on the backs of those who underestimated his ruthlessness. Competent, but highly corrupt. Suspects that Lieutenant Pora is out to get him; Lieutenant Pora is shortly going to suffer an unfortunate "accident" in the weapons lab.

DEX 2D+2, blaster 3D, dodge 3D+1, melee 3D+1; KNO 3D+2, bureaucracy 4D, streetwise 4D; MEC 2D, repulsorlift operation 3D; PER 3D, command 4D, con 4D; STR 3D, brawling 3D+2; TEC 3D+2, security 4D+1.



The Outpost and Its Denizens

Below is the key to the map of the tech post, followed by brief descriptions of the personnel within. The map itself is located in the pullout.

Tech Post Map Key

Rooms 1-20: Research and Design

There are 20 scientists here, working in three areas of research: biotechnology, physics (mainly weaponry and vehicular improvement), and computer programming and design. The biology section in the northeast corner smells like wet bantha. The physics labs sound as if there is a running gunfight going on within (though the more dangerous research takes place in well-shielded areas on the lower floor). The computer room is filled with the cackle of programmers.

1. Surgery. Microsurgery, modified bacta tanks, an ominous-looking drain in the middle of the floor, and an MD-5 series medical Droid, are here.

2. Cage Room. This room is filled with cages of chittering, bleating, mewling animals, ranging in size from the mouselike greeper, to one large cage in the corner occupied by a sickly bantha. There are two technicians here.

3. Office. The office of Dr. Lagg, head of the physics lab, contains a sophisticated overhead holoprojection system. Dr. Lagg keeps a very low-intensity blaster in his desk; when he's bored, he shoots at targets flashed on the walls by the holo unit. He's at it when Rebels enter and mistakes one Rebel for a holoprojection. (Blaster 2D+2; damage 2D.)

4. Office. Physicist Dr. Makim's office is currently empty. There is a disassembled blaster pistol scattered across the desktop (Moderate *Technology* roll, 10 minutes' time to re-assemble).

5. Bio Lab. This large, open area filled with lab tables, has various high-tech equipment scattered about. Four scientists work here, performing various nasty experiments involving living subjects.

6. Physics Lab. The room is filled with a sophisticated computer system, wherein the scientists create models of new weapons and vehicles; all of the actual testing takes place in the labs on the first floor. Currently the room is pitch black, and the Rebels may be surprised to see a beachball-sized Death Star hovering in the air before them.

A second look confirms that it is a holoprojection; if they look carefully, the Rebels can see microscopic TIE fighters and X-wings swirling through the air around them. Several seconds pass, and then the Death Star explodes.

Two scientists are arguing about the destruction of the Death Star. One says that the Rebel X-wings must have found a weakness in the Star's defenses; the other that the Star must have been sabotaged from within. He appeals to the Rebels for support.

"Surely, there's no way those puny ships could have hurt something that powerful, that well-designed." He coughs modestly. "I, myself, had a small hand in the creation of the Death Star. I was part of the team which designed the thermal exhaust ports, you know ..."

7. Office. The office of Dr. Endus, head of Bio lab. Various unpleasant-looking dead animals adorn this otherwise standard office. Dr. Endus talks incessantly about biology in arcane polysyllabic terms, and cannot be understood by anyone with less than 5D in *medicine* and *technology*.

8. Washroom. Standard.

9. Lunch Room. Standard.

10. Office. Dr. Euritarina's office. Dr. Euritarina can usually be found in the weapons testing lab (room 21). A locked display case contains 10 antique blasters. Moderate *security* roll to break into, failure sets off alarm. (Blasters damage 3D+1; they have no power packs.)

11. First Aid Room. Fully-equipped emergency surgery, complete with medpacs (five in a cabinet), bacta tank, various drugs, and a Too-Onebee surgical Droid.

12. Office. Standard.

13. Office. Office of Dr. Gordal, one of the very young geniuses working in the computer labs. Office is incredibly messy; walls are covered with old food and posters of local holostars and sports heroes. A Very Difficult *search* through the computer paraphernalia discovers the prototype of a new memory chip, which, when completed, will increase Droid memory capacity by 48 percent.

14. Security Post. Two security officers are stationed here. They loathe the scientists, fear their experiments, and won't come out except under extreme provocation. There are two blaster power packs in a locked desk drawer (Easy *security* roll). See below for the guards' statistics.

15. Computer Room. Five scruffy young people pounding studiously away at keypads. Despite their nerdy appearance, these are the only scientists sharp enough to see through the Rebels' cover story. If any Rebel attempts to pass himself off as a computer expert, let him make an opposed roll of his *computer programming* skill versus the scientist's skill of 5D+1. If the Rebel wins, the scientist sulks, but is impressed. If the scientist wins by a simple majority, he simply smirks; if, however, he rolls twice as high as the Rebel does, he decides the Rebel is a phony and pleads to be taken along when they make their break.

16. Lounge. Bugged by Security Office and monitored by Communication Center (room 41).

17. Empty Office. Rebels are assigned here temporarily, until permanent offices can be arranged. Desk, chairs, nothing more. The office is bugged and monitored by Communication Center (room 41). If Rebels make friends with any of the computer scientists, they'll warn them about the bug.

18. Office. See room 13; no computer chip.

19. Office. See room 13; no computer chip.

20. Chief Scientist's Office. The room is almost completely bare, consisting of a desk, one chair, and a computer console. Script opens here.

Rooms 21-24: Testing and Storage Area

Captain Hawra sends patrols of two security guards through here every hour.

21. Weapons Testing Lab. This large, well-shielded room consists of two main sections — the machinist's shop and the firing range, separated by 10 inches of warship-grade transparisteel. (Note: an alarm sounds whenever anybody enters or leaves the testing lab with a blaster power pack. The security guards on patrol carry a disabler which overrides the alarm, so it doesn't go off every time they pass through.)

The machinist's shop contains some of the finest weapons repair and construction machinery in the sector, in which six technicians and 12 second-degree engineering Droids build new weapons under the direct supervision of Dr. Euritarina. There are dozens of power packs in a cabinet, and at least 50 blaster pistols, 10 blaster rifles, and three repeating blasters scattered about in various states of disrepair. There are a number of other oddities here too, including a complete AT-AT Walker's heavy blaster lying in the corner, and a fully-powered lightsaber hanging on a wall.

22. Vehicle Testing Bay. A well-equipped garage where several grease-covered scientists and Droids are working on four speeder bikes, one repulsortank, and a tracked device which resembles a bulldozer. The repulsortank is inoperable, the other vehicles more or less so (see "The Chase," below).

23. Storage Area. Door is locked (Moderate *security* roll to open; alarm sounds on failure). Inside, the Rebels find banks of spare machinery, work clothing, chairs, hydrospanners, Droid shells but no weapons.

24. Electronics Lab. Scientific equipment.

Rooms 25-33: Power and Security Quarters

The people in charge thought it would be a good idea if the scientists couldn't get at the power and environmental control area without going through the security quarters.

Over 30 security guards live here, under the command of Captain Hawra. Scientists are *not* welcome in this part of the building — unless they are under arrest.

25. Power and Environmental Controls. One security guard stays in this room, mostly sleeping or playing solitaire holochess. The outpost draws its power from a Verrtog reactor. It's an Easy *Mechanical* roll to shut down the reactor, but it takes a Very Difficult *Mechanical* roll to get the reactor to expire violently.

26. Living Quarters. Fifteen bunkbeds in a special sound- and light-damping field against one wall, and a dozen tables, chairs, couches, etc. scattered throughout the rest of the room. The troopers in this room are unarmed; their weapons rest in neat racks along the wall.

27. Detention Cell. A single, large room. Moderate *security* roll to open from the outside without a cylinder key of the appropriate rank, and Very Difficult to open from the inside; failure sets off an alarm. Captain Hawra and Lieutenant Pora have the proper rank cylinders.

28. Mess. A long, table, seating up to 20 men, is all that is here. A food processor is in the alcove.

29. Armory. Locked. Difficult *security* roll to break into;

failure sets off an alarm. The room contains three dozen blaster pistols, one dozen blaster rifles, 200-odd power packs, and a case of 48 thermal detonators, plus several cartons of broken weaponry awaiting repair.

30. Lieutenant Pora's Office. A bare, almost spartan cell, containing a desk, chair, and cot. Lieutenant Pora's heavy blaster pistol hangs from a hook on the wall when he is in; he has a heavy blaster concealed under his desk, pointing directly at the door. His computer contains the code key the Rebels need.

31. Vehicle Storage and Maintenance. Six speeder bikes, a personnel-carrying repulsorcraft and blaster-equipped speeder are stored here. All are functional, though the speeder bikes' and speeder's weapons have no power packs (they are kept in a locked cabinet until needed). There are four troopers here at all times.

32. Captain Hawra's Quarters. In contrast to other quarters, these are luxurious, almost decadent. Plush carpeting, soothing subsonics, the latest in null-gee sleeping plates. His computer contains the code key the Rebels need. This room is bugged by Lieutenant Pora.

33. Captain Hawra's Office. This room is much less opulent than Captain Hawra's living quarters, containing the standard desk, chairs, and computer terminals. The only things of interest here are several outlandish weapons mounted on the walls, including a Wookiee bowcaster (complete with ammo for 24 shots), gaderffi stick, and force pike. His computer contains the code key the Rebels need. This room is bugged by Lieutenant Pora.

Rooms 34-48: Bureaucratic Level

About 15 civil servants and secretaries inhabit this area, along with two security officers stationed in room 36, and two in room 44.

34. Office. The Project Head's assistant.

35. Project Head's Office. A cluttered office.

36. Lounge. Two security guards are here, keeping track of the scientists going to and from the testing areas.

37. First Aid Room. Identical to room 11.

38. Reception. A small, open room containing a young woman and a data pad. There are two buttons under her desk: one opens the doors into and from room 40, the other sounds a silent alarm in Hawra's and Pora's offices.

39. Conference Room. Big room with oval table and comlink. Bugged by Captain Hawra.

40. Entrance. This area is constructed of thin transparisteel (*Strength* 4D).

41. Communication Center. A young woman controls communications into and out of the post from here. She's IntSec, reporting to Lieutenant Pora, and listens to all calls.

42. Office. Random bureaucrat.

43. Supply Cabinet. Locked, Moderate *security* roll to open. Contains office supplies.

44. Lounge. Same as room 36, except that the troopers are here to keep the scientists out of the security section of the building.

45-48. Offices. Standard.

Events

Following are several events which might take place while the Rebels are in the outpost. You can run as many or as few as you like; just remember that this episode is meant to be light-hearted in tone, so don't get too bogged down in detail.

If any of the events lead to violence or a chase, go to "The Chase;" otherwise, once the action begins to lag, have the day end and the transport repulsorcraft arrive to take everyone (except the security guards, of course) back to the city. Go to episode two.

Event One: Meet Dr. Benkin

Shortly after the Rebels finish accessing his computer and dealing with the technician who interrupted them, Dr. Benkin returns to his office. A remarkably old man, Dr. Benkin teeters on the verge of senility and hasn't the foggiest idea who the Rebels are or why they are here. Once they explain, he is even more confused.

"I'm sure I didn't *request* any additional staff," he says, dubiously. "We're overstuffed as it is — I *think* we are. Aren't we? I have no idea where I'm going to put you all. There must be some mistake. I had better get in contact with Personnel Routing at Market City. Er, what did you say your names were again?"

The Rebels may attempt to talk Dr. Benkin out of contacting Personnel Routing; it takes an Easy *con* roll to sufficiently befuddle the old man. If not, in four hours Personnel Routing sends a priority message to Captain Hawra, telling him to place the Rebels in custody until they figure out who they are.

Event Two: The Tour

As soon as possible, Dr. Benkin turns the Rebels over to another scientist and instructs him to take them first to their office (room 17) and then on a tour of the facilities. The scientist will not take the Rebels into the security offices or the power room; both are off-limits to scientists.

Use the map provided, and let the Rebels encounter the rather odd characters and situations described in the map key, above.

Event Three: A Few Routine Questions

After the Rebels have had a chance to look around, Captain Hawra sends an officer to "invite" them to have a chat. The officer takes them to the conference room (room 39), and then escorts them, one at a time, into Captain Hawra's office (take the player out of the room and conduct the interview with his character away from the other players).

Hawra asks the Rebel a few routine questions about his or her previous posting on Dakot (Moderate *con* roll — remember that the Rebels

get a +1D to their *con* skill). Whether or not the Rebel makes the roll, Hawra then hits him or her with a nasty surprise. Pick one of the following bits. After the interview, send the player into another room; don't let him or her talk with any of the other players until all the interviews are over.

1. "I suppose you know my brother, Messtin, the assistant security chief at Dakot Tech. How's he doing, anyway? *The Rebels' briefing didn't mention an assistant security chief at all. There isn't one, and Hawra doesn't have a brother. Rebels who reply that they never had the pleasure are fine; those who try to pretend they met Messtin are in trouble.*

2. "Very interesting — but a complete pack of lies. I'm afraid that your comrade already confessed to everything — in exchange for his pitiful, worthless life. I suggest you do the same." *If the Rebel protests his innocence, he's fine.*

3. "Hmmm. Would you mind placing your hand on this and repeating the answers?" Hawra takes out a portable truth meter and puts it on the desk. *The truth meter isn't very accurate; If the Rebel passes a Moderate con roll, he's fine.*

4. "You're lying. You are a Rebel spy. I will now kill you if you do not name your contacts on this planet. I shall count to three." Hawra takes out his blaster, points it directly at the Rebel's head, and begins counting. *Protesting innocence, cringing, running away, etc., are all acceptable responses.*

After each Rebel is questioned, he is taken into the mess (room 28), where several security officers keep an eye on him until all the others have been questioned. If any of the Rebels fail the test, they are placed in the detention cell (room 27).

Event Four: Breaking the Code

If the Rebels try to sneak into either Hawra's or Pora's private offices (rooms 30, 32 and 33) to access the unrestricted computers, here's what happens.

Let any reasonable plan get them into the office, just as long as they have not been forced into a chase scene. If they have given themselves away, they'll have to do some fighting or expert sneaking to get at the unrestricted computers.

Otherwise, either a subtle *con* job (dressing as security guards, cleaning people, etc.) or a good diversion (exploding one of the labs, taking the project head hostage, simulating an attack on the post) can get them to the computers.

While QT-7 is busy downloading the proper files, have Hawra or Pora enter so that you can finish with a big chase. Do this especially if the Rebels have had an easy time of it during this



episode. After a few minutes, QT-7 blurts out cheerfully, "All done! I've got the code key! But the files have been programmed to self-destruct if you try to run them together. You'll have to decipher the information manually. Sorry, guys." With that, the Droid displays "The Key Code" on one of his screens. Show the players the handout from the pullout.

Ending the Episode

It is possible, though not entirely likely, that the Rebels will finish their mission without getting into a fight or chase. If so, you have two choices:

- You can simply let them get off scot-free. At the end of the workshift, a large multi-passenger repulsorcraft arrives, and all of the scientists pile into it. It heads back into town, wherein the Rebels slip away, get in touch with their contact, and head off-planet.
- You can blow their cover sky-high. Just as the Rebels are feeling safe, they are tripped up by one of those unfortunate accidents which happen to even the best operatives. Dr. Benkin shows up with another recent transfer from Dakot (who doesn't know the Rebels), Hawra (or Pora) arrives just as QT-7 finishes with the computer download and demands to know what is going on, or one of the secretaries turns out to be an old friend of one of the Rebels from pre-Rebellion days and innocently asks when he or she became a scientist. Now go to "The Chase."

The Chase

The outpost is a medium-security facility, built more to repel external attackers than to keep them inside. Determined Rebels should be able to escape with relative ease if they are forced to fight or flee. Following are the main components of the post's security system.

Security Doors: When the alarm sounds, all the external doors and the internal security bulkheads slam shut and lock; however, the Rebels can take a rank cylinder off of any of the security guards, or off of Dr. Benkin. These can open the doors. Otherwise, they must make a Moderate *security* roll to open each door they encounter. If they think to ask QueTee, the Droid can do it automatically from any computer terminal.

Stun Fence: The outpost is surrounded by a three-meter-high meshed fence. When anyone touches it, powerful energy shoots through his body, stunning him (6D stun damage).

Unfortunately, when the field is engaged, the power surge shorts out the post's communications system, cutting the outpost off from the rest of the world until the comlink can be repaired (in three hours).

The stun fence can be shut off only from the reception desk (room 38), or through the computer system (Difficult *computer programming* roll — QueTee can do it automatically). Alternatively, the Rebels can shoot out a transformer with their blasters (Difficult target to hit; the transformer has a *Strength* of 3D); or, more primi-

tively, simply drive one of the large repulsorcraft straight through the fence.

The Minefield: Outside the fence is a belt of electronic mines, 30 meters in width. Since installed, an average of five mines per day have exploded on contact with the denizens of the swamp, and the security personnel have gotten tired of replacing them. Thus, the mines are deactivated until needed. When the Rebels make their break, the guards activate the minefield.

It takes six rounds to pass carefully through the minefield. Roll a die each round that a Rebel is in the minefield: a roll of 6 indicates that he or she is approaching a mine. If the Rebel makes an Easy *Perception* roll, he spots the mine and can avoid it; otherwise, the Rebel blunders into it, taking 3D damage. Note that if the Rebels walk one behind the other, only the first in line is at risk. The mines are ineffective against repulsorcraft.

Here's the Plan

Once the fighting begins, the Rebels have three choices: they can stay inside and attempt to defeat all 30-odd security guards; they can break out of the post and enter the swamp on foot; or they can steal one or more of the vehicles in either room 22 or room 31.

- *If they attempt to defeat all of the security guards:* Good luck to them. The first few rounds of combat will probably go their way — as the guards are surprised and disorganized — and they will no doubt take care of the first few with ease.

Soon, however, Captain Hawra gets things under control. He sends six men to harass the Rebels, while all of the guards on patrol outside the building move to cover the exits and the off-duty guards in room 24 get kitted-up. Once they are ready (eight to 12 rounds), he sends them in to overwhelm the Rebels.

Meanwhile, the weapons testing and research scientists will be thrilled to have a chance to test their weaponry in a live combat, and they begin showing up and firing off dangerous, untested weapons, doing little damage but scaring the living daylights out of everybody. Each round, roll a die: on a 1, they get off a lucky shot, hitting a Rebel; on a 6, they hit a security guard (variable blaster damage, from 1D to 6D); on any other roll, they merely make a lot of noise.

If the Rebels manage to kill or wound 20 of the security guards, the remainder retreat into the security section, despite all Captain Hawra's entreaties. The Rebels have an hour to make their escape before 50 stormtroopers show up in military transports.

- *If the Rebels break out of the post and escape on foot:* Again, best of luck to them. Getting outside

the post isn't that big a problem. The Rebels should be able get through the doors, beat up the guards, and negotiate the stun fence and minefield with relative ease. However, they may have a little more trouble making their way through several dozen kilometers of virgin swamp while hundreds of security troopers and stormtroopers from the city are looking for them.

The trip will take a minimum of 24 hours. Each hour, roll a die to determine the encounter:

1. Patrol: Consisting of 10 stormtroopers or security officers on speeder bikes. Moderate hide/sneak roll to evade; otherwise, they will send in their position via comlink, and then attack. An additional 10 troopers will arrive in 10 rounds, and every 10 rounds thereafter until the Rebels escape or are captured.

2-4. Nothing.

5-6. Natural Hazard: Alligator-like creatures (DEX 2D+1; PER 2D+1; STR 4D; bite damage 4D+2), quicksand (Moderate survival roll to avoid), poisonous snakes (DEX 3D; PER 2D; STR 2D; damage 3D+2), carnivorous plants (DEX 2D; PER 1D; STR 3D; damage 5D), etc.

- *If the Rebels steal speeder bikes and escape:* The security guards' bikes are standard Aratech 74-Z military speeder bikes; the scientists' bikes have been modified. If the Rebels take the security guards' bikes, then the security guards get to enjoy the scientists' modifications; otherwise, the Rebels do. If the Rebels take the scientists' speeder bikes, the guards give chase in a number of minutes equal to the roll of a die; if they take the guards' bikes, they get a lead of twice as many minutes.

After they have lost or destroyed all of their pursuers, the Rebels' journey to the city is uneventful (though you may wish to throw a natural hazard at them if they have had too easy a time).

Speeder Bikes: Speed code 4D (2D); maneuverability 3D+2 (1D+2); body strength 2D. Weapons: laser cannon: fire control 2D; damage 3D (5D). The parenthetical codes refer to the scientists' modified bikes. Use these codes for two rounds following a round in which the modified bike's laser is used.

Accidents Will Happen

If the Rebels are captured, they are taken into the city and thrown in prison. If you are feeling inventive, you can extemporize a prison-break scenario; otherwise, you can have the Rebels' contact in the city get them (and QT-7) out of jail. (Remember to reduce the skill points awarded at the end of the adventure by two if they were captured here.) Go to the next episode.

E

pisode Two

The Plan

Summary

The Rebels return to Alliance Sector Headquarters and, with the datafiles stored in QT-7, help Major Lawra Mers plan a daring raid against the Imperial replenishment fleet.

Unless something truly unusual occurs, there is no overt action in this episode. The Rebels meet with their superior officers, get healed if necessary, and get ready for the big attack coming up in the next episode.

This episode is important, however — it serves to advance the plot, introduce new characters, and signals a major tone change in the adventure — but there's no action in it.

Debriefing

The Rebels' contact on Lotide smuggles them off-planet and sets course for Fangol (see sidebar), the planet hiding the secret Alliance Sector Headquarters. Read the following aloud:

Your return voyage to Sector HQ is uneventful. The descent into the sensor-jamming mists shrouding the planet Fangol is, as always, quite unnerving, but the captain makes a near-perfect eyeball landing. Then, he ushers you off of his vessel, and roars back into space.

Your reception committee, six Alliance soldiers with drawn blasters, scans you thoroughly and escorts you into a shielded conference room where you await the arrival of your field mission commander, Major Lawra Mers.

As usual, Mers keeps you waiting for almost an hour. She bustles in, looks you over, then nods at the escort, saying formally, "I vouch for these people. They are true friends of Liberty." The guards return your weapons and depart.

The major sighs and plugs QT-7 into a computer jack. Satisfied that the hook-up is working, she slouches down into a chair, closes her eyes, and says, "All right. Report."

Let the Rebels make their report. Don't have them go into exacting detail, but give them the opportunity to present the highlights for Lawra's approval. After they finish, read:

The Mists of Fangol

The Rebels are aware of all of the following information.

Alliance Sector HQ is located on Fangol, a small, cold planet on the very edge of Mortex Sector. Totally shrouded in pure white mist which reflects all but a small fraction of the sun's light, Fangol shines like a candle in the empty blackness of space.

Thrown up by ice volcanoes scattered across the planet's face, the mist is composed of water vapor contaminated by a heavy concentration of metals and other elements. The metal-rich mist makes sensor scans of the surface all but impossible, rendering the base beneath it virtually invisible (and making flying into or out of the planet somewhat unnerving).

Of course, the base cannot see up out of the mist, either. The base's communications and sensors are contained in a small, artificial moon in geosynchronous orbit above the base. In addition to the sensor and communications gear, the moon is equipped with a powerful low-frequency transmitter which easily punches through to the base below. In the event of unwanted visitors, the sensors shut down and the station plays dead. As it is manned entirely by Droids, casual scans of the moon reveal it to be somewhat metal-rich, but nothing more.

The base on Fangol is buried deep underground. Temperatures on the planet rarely reach above minus 110 degrees Galactic Standard and the air is Poisonous, so Rebels go on the surface only at great need. The base's power is drawn from thermal collectors sunk into the planet's molten center.

Roughly 3,000 Rebels occupy the base at any one time. One third are administrators, one third support personnel — workers, doctors, communications experts and the like. The final third are warriors. The base is equipped with 100 starfighters, five corvettes, and six light freighters.

The major stands, motions for QueTee to unplug, and says, "You've got 24 hours. See what you can make of the code and get yourselves fixed up. I'll have a new assignment for you tomorrow." As she leaves, she says, "Not too shabby." From her, that's high praise, indeed.

What to do for 24 Hours

The Rebels first action must be to decipher the coded datafile that they recovered from Lotide. Then, after they have presented it to Lawra, healed up, and recovered their weapons and other equipment, you could fade right into the next scene. Or you could let them wander the base and visit with any interesting Alliance NPCs from your campaign.

The Scam

After 24 hours, the Rebels are summoned to a meeting with Major Lawra Mers and Captain Dargen Io, the sector Chief of Supply. Read aloud:

You are summoned back to the conference room where you were debriefed. The major is there, along with Captain Dargen Io, Sector Chief of Supply. Major Mers looks excited — a bad sign. Every time the major looks excited, someone ends up volunteering for a dangerous mission. This time is no exception.

The major speaks. "Nice job on that infiltration, folks. With the information you picked up, we know that an Imperial replenishment fleet is stopping at Refrax for resupply and routine maintenance. We've checked our intelligence on the spaceport and made a decision. We're going to hit it. You want in?"

Lawra explains the situation. The Imperial replenishment fleet's escorts have more than enough firepower to deal with the small Alliance forces in the area — under normal circumstances. However, the flight plan suggests that Refrax presents a perfect opportunity for the Rebellion. With only a token force in space and the majority of the escorts grounded at the near-orbit spacedock for standard maintenance, the cargo vessels are virtually defenseless.

In the event of Rebel attack, the escorts in space, plus several units of anti-space artillery, would hold off attackers until the grounded vessels could leave the dock and join the battle.

The Rebel attack, though, will be spearheaded by a group of Rebels whose job will be to infiltrate an anti-space artillery bunker. When the next wave of Rebels follow, these infiltrators will bombard the spacedocks to shut them down, and then engage the other anti-space weapons. The Rebels attacking in space will only have to deal with the escorts already in orbit.



T-7's Display Screen

This is what the datafile from Lotide looks like when the code is broken.

:Priority Flight Plan *** Imperial Replenishment Fleet DK-209

:Restricted Access *** Security Code DV5

:Command Clearance Only

:Imperial Replenishment Fleet DK-209 ships—

Three Maintenance Carriers (*FarRun, Fixer, Quartermain III*)

Six Bulk Freighters (*Talsor, Fasan, Cargo I, Cargo IV, Star Bantha, Colo's Ship*)

Two Container Ships (*Cargo X, Bounty*)

One Container Train (*Black Ice*)

Five *Lancer*-class Frigates (*Lancer I-V*)

Three Escort Frigates (*Protector II, Guardian, Security I*)

:Fleet course via hyperlane GG734 to Refrax Spaceport for supply transfer and routine maintenance. *Black Ice* to be loaded with high-grade starship power cell fuel from planetary refinery. *Lancers II-IV, Guardian, and Security I* scheduled for spacedock overhauls before next leg of trip.

:Overhauls scheduled to be complete within 48 standard hours.

:Cargo transfer to be complete within 36 standard hours.

:Imperial Replenishment Fleet DK-209 continues on via hyperlane GH972 to rendezvous with Assault Fleet EM4 in Kestel system.

So What's the Catch?

Read aloud:

Dargen speaks next. "As you know, ever since the Imperials hit our refinery in the Choah Belt, our local operation has been critically short on fuel. We've got barely enough to sustain normal operations, and this exercise is going to seriously deplete our emergency reserves. We need more fuel."

Mers interjects calmly. "You folks are going to get it for us."

Several weeks ago, Sector HQ acquired two Imperial *Spiral*-class ship assault vessels—Lawra doesn't say how. These are small, needle-shaped craft, specially designed to bore their way through an enemy vessel's particle shields and straight into the side of the ship. Then the assault team

The *Black Ice* Diagrams

The full-spread diagram of pages 20 and 21 is "The Engine Pod." It shows one of the two engine pods that make up *Black Ice*. Basically, *Black Ice* is two engine pods, one set on each end of connected force spheres, forming a cargo train in space. These pods move the massive train by pushing in one direction at a time. This map shows the layout of one engine pod, including the position of the command capsule.

The schematic on page 23 is "The Command Capsule" close-up. It shows the positions of all relative areas used by the crew.

The diagram on page 24 is "The Scale Diagram." It shows the players just how big *Black Ice* is by placing it beside an *Imperial*-class Star Destroyer. Also on this page is a visual on how the individual force pods operate.

emerges and captures the vessel before its crew knows what hit them.

Lawra wants the Rebels to man one of the assault vessels, and in conjunction with a team on the other *Spiral*, to board and commandeer the Imperial fuel container train assigned to the replenishment fleet.

She provides the Rebels with a schematic of the container train (give the players the maps on pages 20, 21, 23 and 24 of the pullout), introduces them to their counterparts in the other assault ship, and lets them plan their attack. The Rebels comprise Black Team; their assignment is to secure the aft engine pod. The other assault ship is manned by White Team; their assignment is to commandeer the forward engine pod.

White Team

Here are thumbnail sketches of White Team so that you can characterize them during the planning session.

White Team Leader: Untos Poquot, a bitter, taciturn man. Lost his wife on Alderaan. Hates the Imperials with an unsurpassed fury. A good planner despite his passion.

Second in Command: Worrumba, a Wookiee. In Life Debt to Poquot. More interested in protecting his friend than in aiding the Rebellion.

Team Members: Four Rebels — two human, two Mon Calamari. Enthusiastic, headstrong. Are sure that a Rebel can whip any 10 Imperials. Should make the Rebel heroes very nervous.

The Plan

Let the Rebels devise any plan they want, as long as they are within the parameters of the assignment — to secure the aft engine pod of the container train.

White Team Leader says that his group will hit the communications level, just below the bridge. From there, his team will make its way up to the bridge, secure it, and radio the aft engine pod to see how Black Team is doing. He does not care how the Rebels get their part of the job done, as long as his people don't have to worry about trouble from the aft.

The Rebels may come up with back-up plans in case of emergency — if so, they will be much better prepared next episode, when everything falls apart. If not, they are going to have to improvise on the fly.



E

pisode Three
Cracking the Ice**Summary**

The Rebels board the aft engine pod of the Imperial container train *Black Ice*. The *Ice*'s crew puts up a hard fight, but the Rebels eventually prevail, as do White Team, who board the *Ice*'s forward engine pod.

After the ship is secured, the Rebels coax the huge vessel into hyperspace.

Final Preparations

Sector HQ bustles with activity as hundreds of Rebels prepare for the attack against the Imperial replenishment fleet. Dozens of serious-faced Rebel pilots listen to attack instructions from their mission officers, and maintenance personnel and Droids work feverishly to get the base's spacecraft ready for the attack.

The Spiral

Gren Lavorn, the base's spacecraft maintenance officer, shows the Rebels the ship they will use in the assault, a *Spiral*-class vessel designed to penetrate hull and shielding. Over 70 percent of the ship is subspace engines and shield generators, giving the *Spiral* power but no grace.

If the Rebels decide to look over their ship for flaws before they take off, have them make *Moderate starship repair* rolls. If successful, they discover a potential flaw in the trim jetflow regulating subsystem, which is easily repaired by the chagrined maintenance personnel. If they don't spot the problem, the ship's maneuverability is decreased from 1D+2 to 1D+1.

Once everything is ready, the two Spirals are loaded aboard a freighter for transport through hyperspace.

Equipment

The *Spiral* is severely limited in cargo space, allowing each passenger to carry only a few small items in an overhead bin and not much more in a rear cargo compartment. There's only enough room inside the craft for each of the Rebels to stow a knife, blaster pistol, two spare ammunition packs, and a medpac. All other equipment must be stored in the rear cargo compartment,

Assault Ship

The *Spiral*-class is a single-use, small-unit boarding craft, designed for the rapid insertion of special forces into non-military vessels or space stations. The ship is equipped with no ranged weapons at all, instead relying on stealth technology to keep targets from spotting it until it is too late.

When the *Spiral* hits the target's particle shielding, the shaped proton charge detonates, disrupting the shields for a fraction of a second — long enough for the *Spiral* to burn through and bury itself into the target's side.

The *Spiral*'s nose cone is composed entirely of sublimating tektonite, which vaporizes upon collision, absorbing nearly 92 percent of the kinetic energy of the impact, insuring that the ship's cabin survives the collision virtually intact. Additional protection to the passengers and crew is provided by inertial-damping grav couches.

Once inside the target, the vac-suited passengers exit and overwhelm the stunned crew of the boarded vessel.

***Spiral*-class Assault Ship:** Hyperdrive multiplier zero; sublight speed 4D; maneuverability 1D+2; hull 5D. Weapons: One-shot proton charge; fire control zero; damage, see above. Shields 2D+2.

which will hold any two of the following: two weeks' emergency rations, up to four blaster carbines and extra ammo packs, six medpacs, 24 grenades, and QT-7.

The Rebels are advised to take the computer access Droid with them, as QT-7 will be needed to talk to the train's computers.

Arrival

Read the following aloud:

It's no fun going into battle blind, stowed aboard a slow, virtually defenseless freighter. But there isn't a lot you can do about it, so you

tune in on the Alliance command frequencies, trying to get an idea of how the battle is going.

“... Leader, bogey at 4 o'clock, neg 90 ... Red Team, form on me; let's make our run ... Got 'im! Whooweee! ... Yellow Team's here; they've taken the artillery bunker ... scratch one ammo ship; going to secondary target ... Green Team reports heavy damage to spaceports, estimated repair time four — I say again — four *beautiful* hours! ...”

The battle seems to be going well. Several moments later you hear, “Black and White Team, prepare for launch.” Within seconds, the after hatch on the freighter opens, sending both assault ships into space.

At last you can see the battle raging all around you. X-wings and Y-wings dart across the stars, spitting fire at the outnumbered TIEs. Nearer to the planet, Imperial freighters lie in orbit, some burning visibly, some limping desperately out of the gravity well toward space, hounded mercilessly by powerful B-wings.

You bring your mind back to business and find *your* prey, the huge, black string of pearls directly ahead. It's bigger than you expected, and it appears to be about 500 kilometers away. You check your instruments.

Then you recheck them.

The schematics were correct. That *thing* out there is 7,800 meters long — five times the length of an *Imperial-class* Star Destroyer.

More details become apparent as you close with the train. The *Ice* is composed of three main sections: two huge engine pods, and between them, the cargo fields, nine shimmering black balls of force, each containing 110,000,000 tons of high-grade starship fuel. You try not to think about what would happen if you missed your target and crashed into one of them ...

Your sensor beeps: 10 seconds to impact. You make your final course adjustments and activate the inertial couches — you're now totally helpless until you slam into the vessel or miss ...

... eight, seven ... the shielding lowers over the transparisteel, leaving you blind ... six, five, four ... you hear a “click” as the proton charge arms itself ... three, two — *WHUUMMMMP!!! Screeeeeeee!*

You're through the shielding! One second to impact —

There's a sudden wrenching shock to your body. Everything goes black.

The Battle for *Black Ice*

The Rebels find their ship buried nose-first somewhere within the Imperial container train. Where? To find out, have the pilot make a *starship piloting* roll. If he passes a Difficult roll, the *Spiral* is exactly where he wanted it; if the roll is Moder-

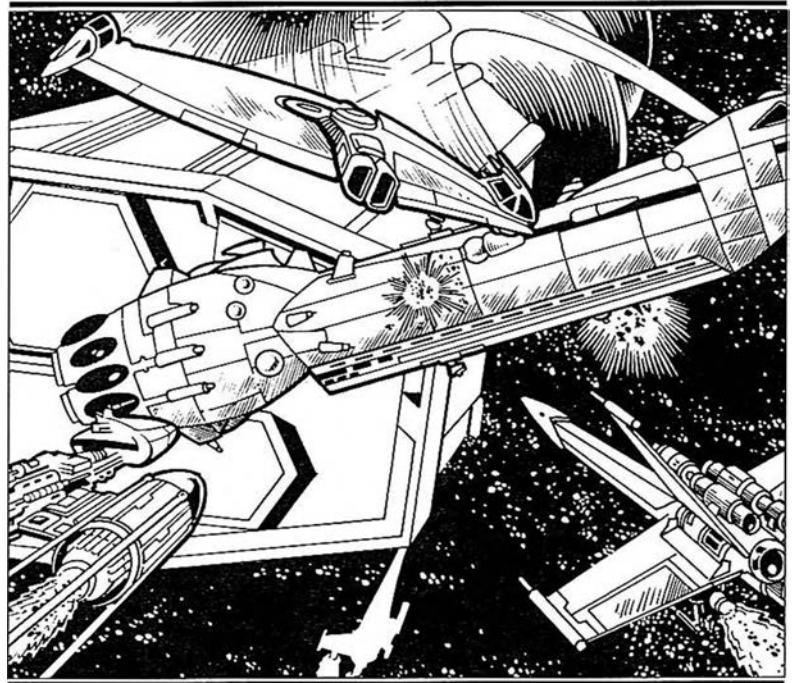

ate, it is within 50 meters of its intended destination; if the roll is within only Easy or Very Easy range, they are somewhere on the command unit, but about as far away from their intended target as possible. If the roll failed, the *Spiral* hit somewhere in the engine pod. The assault ship is a ruin. The entire nose section vaporized upon impact — as it is supposed to do — and the engines are inoperable. The Rebels have no choice but to grab their gear and head off.

The corridor section outside is, of course, in vacuum. Everyone must remain in their vac suits until they clear into a secure area.

First Encounter

The Imperials are not yet sure what is going on — all they know is that a section of the ship was breached, but they are unsure if the ship has been invaded, or merely hit by wreckage from the battle outside. They immediately send a party of repair Droids to assess damage and seal the breach, followed, several minutes later, by six vac-suited Imperials carrying repair equipment and, somewhat gingerly, blasters.

If the Rebels have moved quickly, they can escape into a side corridor, gaining another few precious minutes before the Imperials learn exactly what they are up against. Otherwise, they have to fight.

The Landing Bay

If the Rebels aimed for the landing bay and the pilot of the assault craft made his *starship piloting* roll, then the ship passes straight through the

magnetic shielding and comes gently to rest on the floor of the bay. The assault craft is undamaged, and the Rebels are unharmed. The magnetic shielding quickly resealed itself after the Spiral passed through, maintaining the atmosphere in the bay.

There are two or three very surprised Imperials staring at the invaders' ship; but, as none of them are armed, they are easily taken care of — but not before one of them raises the alarm, telling the bridge that they have been invaded.

The Firefight

To commandeer the *Ice*, the Rebels must reach the pod's bridge. This is not difficult: there are only 10 security guards in their half of the vessel, and they are completely surprised by the attack.

If the Rebels move quickly, before the Imperials have time to get their defense organized, they should have little trouble.

The First Dash

Unless you are particularly interested in drawing up the floorplans of the *Ice's* command capsule and forcing the Rebels to thread their way through the maze of corridors, we suggest that you handle movement abstractly.

Since the Rebels have a schematic showing the layout of the command capsule and they can find their location on any computer terminal, run the sequence as a series of vignettes. Present the Rebels with short problems and skill tests to move them closer to their objective. At all costs, don't get bogged down in detail.

A bout *Black Ice*

Black Ice is a container train, designed and built by Rendili StarDrive, builders of the *Victory*-class Star Destroyers. At full size, with all force containers active, the *Ice* is 7,800 meters long, with a weight of 1,210,000,000 metric tons.

Cargo Holds: Most of the *Ice* is cargo space. The nine black balls, 600 meters in diameter, are force fields, each contained between field projectors. The balls are filled with refined fuel for power cells — 110,000,000 tons in each. A large conduit runs down the center of each hold, carrying power from the engine units to the force fields and connecting the engine units with each other. Balls can be added or removed to change the size of the train.

Engine Pods: The two engine pods are huge, dwarfing even the engines on Star Destroyers and rivaling those on the Death Star. The fore and aft engine pods are identical (as the ship moves in either direction with ease, the terms "fore" and "aft" change from trip to trip, depending upon which way the vessel is moving).

Command Capsules: The crew spends most of its time in the command capsules which sit atop the engine pods. These are 330 meters in length and 75 meters wide, about the size of a frigate. The entire ship is controlled from these capsules, and the crew is rarely required to enter the engine pods, and almost never visits the cargo balls.

Crew: Despite its huge size, *Black Ice* virtually runs itself, requiring a standard crew of only 200 — 100 in each capsule. As half of the *Ice's* crew is on shore leave, there are only 50 crewmembers currently in each, the highest ranking being second lieutenants.

Standard Crewmen (40): DEX 2D, blaster 2D+2, brawling 2D+2; TEC 3D, computer, Droid or starship repair 3D+2; all other attributes and skills 2D.

Security Guards (10): DEX 2D, blaster 3D, dodge 2D+2; STR 2D+2, brawling 3D; TEC 2D, security 3D; all other attributes and skills 2D.

Ship's Officers (2): DEX 2D+2, blaster 3D+2; KNO 3D, planetary systems 4D, technology 3D+2; MEC 2D, astrogation 4D; PER 3D, command 3D+2; all other attributes and skills 2D. (Note: there is one additional officer on the ship; the Rebels will meet him in the next episode.)

Droids: The engine pods are maintained by a diverse population of maintenance and repair Droids, ranging in size from the EB-89 Engine Maintenance Droid, fully as big as a stock light freighter and armored to withstand the backblast from a firing sublight engine, to the mouselike SW1-04 Computer Repair Droid.

The Droids function completely on their own; when human supervision is required, humans communicate with the Droids via personal Droid/Human interfaces (comlinks with data pads), or through the Droid Control Stations in Secondary Engineering and the Maintenance Section.

The Droids' attributes and skills are described in the next episode.

Transport: The ship is crisscrossed by a complex system of walkways, repulsortubes, and crawlspaces. In addition, each engine pod contains a low-powered shuttle for longer journeys and for carrying heavy loads. The shuttle travels through the cargo balls, connecting the fore and aft engine pods.

B lack Ice Adventure Script

Use the following script to start your adventure. Your gamemaster will tell you what part (or parts) to read.

1st Rebel: Okay. This is Chief Scientist Benkin's office. You keep an eye on the hallway; I'll plug QueTee-Seven into the computer outlet. All set, QueTee?

GM: (As QT-7.) Sure, Boss! Ready, willing, and able! Lemme at 'em!

2nd Rebel: (Muttering.) Cutey. Swell name for an overenthusiastic suitcase. Who thinks those things up, anyway?

GM: (As QT-7.) I heard that! What's wrong with my name? I think it's a good name. Do you *really* think it's a bad name?

3rd Rebel: Pipe down, both of you! We're in the middle of an Imperial Tech base, surrounded by who knows how many Imperial Security Bureau guards, and you two are arguing about a name! QueTee, get to work!

GM: (As QT-7, muttering.) Well, *he* started it ... (*kerchunk*) ... whirr, click, beep, beep, bzzzzz...

4th Rebel: How long's this gonna take, anyway?

5th Rebel: Between five and 45 minutes — a lot shorter if the security programming picks him up ...

6th Rebel: That'd be interesting. What do you think they'd do to six unarmed enemy spies caught in the middle of a high security outpost?

4th Rebel: Probably give us a medal for stupidity above and beyond the call of duty ...

2nd Rebel: Hey, we did volunteer for this mission, you remember.

6th Rebel: Really? I remember being reassigned to Major Lawra Mers of Sector HQ, listening as she briefed us on a new mission, and then being personally thanked by the major for volunteering — but I do not remember actually stepping forward ...

1st Rebel: Stop complaining. This isn't such a bad job.

3rd Rebel: Says you! I have trouble pretending to be a top-notch Imperial scientist. It goes against my nature. And I really feel naked without my blaster.

5th Rebel: Does anybody know if there are any stormtroopers on this post? I hate stormtroopers.

2nd Rebel: We may get a chance to find out. Here comes a technician now.

1st Rebel: Okay, everybody, act like scientists.

3rd Rebel: (Under his breath.) Act like scientists?

6th Rebel: (To Technician.) Uh, er. Hello there. Nice day isn't it?

GM: (As Technician.) Sure is. What are you guys up to, anyway?

4th Rebel: We're, uh, calibrating the, uh, resistance coefficient modulator on the ...

5th Rebel: ... the, uh, the subatomic frequency bonding refractor in the chief's computer. See, it's been acting up lately and ...

GM: (As QT-7.) Hi guys; I'm back! Security system was a piece of cake! I've accessed the information but ... say, who's the new guy? ... Uh oh ...

Major Lawra Mers

Template Type: Alliance Major
Ht: 1.7m Sex: Female



- | | |
|------------------------|-----------------------|
| DEX 3D | PER 3D |
| Blaster 4D | Bargain 4D+2 |
| Dodge 4D | Command 5D |
| KNO 3D | Con 4D+1 |
| MEC 4D | STR 3D |
| Starship Piloting 4D+1 | TEC 2D |
| | Comp. Prog./Repair 4D |
| | Medicine 3D |

Physical Description: Imposing and striking, Mers can also appear fragile when she needs to.

Equipment: Blaster pistol (damage 4D), data pad, com unit.

Background: Mers has quickly risen to the post of field mission commander for the Alliance. She coordinates dozens of strike teams and agent groups, and has specifically requested command of the Rebel heroes because of their string of successes.

Personality: Lawra loves her job as much as she hates the Empire. But the excitement of a mission is everything. It is an honor to be volunteered for an assignment, and she bestows such honor on her charges regularly.

Quote: "This mission is dangerous, perhaps suicidal. I know you want the job, so it's yours."

Chief Engineer Skolos

Template Type: Engineer
Ht.: 1.9m Sex: Male



- | | |
|----------------------|-------------------------|
| DEX 2D+1 | PER 2D+1 |
| Blaster 3D+1 | Con 3D+1 |
| Dodge 3D | Hide/Sneak 4D+1 |
| Grenade 3D+1 | Search 4D+1 |
| KNO 4D | STR 2D+2 |
| Technology 6D | Brawling 3D+2 |
| MEC 2D+2 | TEC 4D |
| Starship Piloting 3D | Computer Programming 6D |
| | Droid Programming 5D+2 |
| | Starship Repair 6D+1 |

Physical Description: Skolos is a large man who looks out of place around delicate machinery.

Equipment: Blaster pistol (damage 4D), data pad, comlink, grenades (damage 5D), tool kits.

Background: Skolos is a hard, dedicated man who loves to repair and maintain machinery. He cherishes Black Ice, feeling that it is his vessel, as he has been assigned to it for two years now. He isn't extremely pro-Empire, as he tries to stay oblivious to politics, but he hates pirates as he has had run-ins with their kind in the past.

Personality: Normally quiet, Skolos will use his size and strengths — both physical and mental — when pushed to his limit. He is beyond it in this adventure.

Quote: "Work is the only measure of worth. Pirates don't work — they take. They have no worth."

QT-7's Display Screen

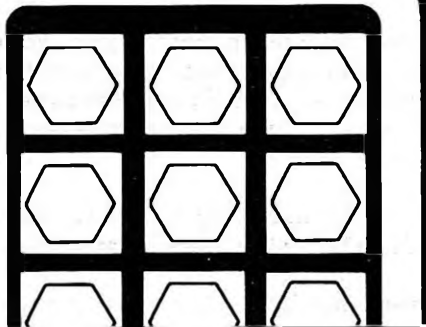
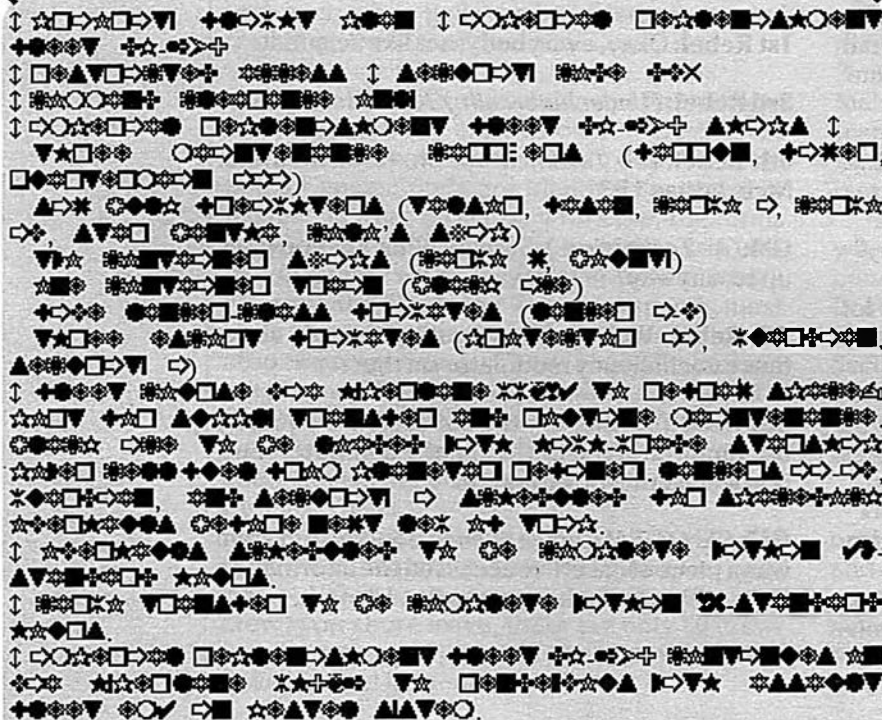

The Key Code

Priority Key Code *** Imperial
Replenishment Fleet DK-209
:Restricted Access ***
Security Code DV5
:Command Clearance Only

A	*	N	■	1	☞
B	⊗	O	☆	2	☞
C	⊗	P	☆	3	☞
D	⊕	Q	□	4	☞
E	⊕	R	□	5	☞
F	⊕	S	▲	6	☞
G	*	T	▼	7	☞
H	☆	U	◆	8	☞
I	◇	V	◇	9	☞
J	*	W	⊕	0	☞
K	☆	X	*		pause ↑
L	●	Y			
M	○	Z			

Tech Post Map Key

- | | |
|-------------------------------------|-------------------------------------|
| 1. Surgery | 26. Living Quarters |
| 2. Cage Room | 27. Detention Cell |
| 3. Office | 28. Mess |
| 4. Office | 29. Armory |
| 5. Bio Lab | 30. Lt. Pora's Office |
| 6. Physics Lab | 31. Vehicle Storage/
Maintenance |
| 7. Office | 32. Capt. Hawra's Quarters |
| 8. Washroom | 33. Capt. Hawra's Office |
| 9. Lunch Room | 34. Office |
| 10. Office | 35. Project Head's Office |
| 11. First Aid Room | 36. Lounge |
| 12-13. Offices | 37. First Aid Room |
| 14. Security Post | 38. Reception |
| 15. Computer Room | 39. Conference Room |
| 16. Lounge | 40. Entrance |
| 17-19. Offices | 41. Communications Center |
| 20. Chief Scientist's Office | 42. Office |
| 21. Weapons Testing Lab | 43. Supply Cabinet |
| 22. Vehicle Testing Bay | 44. Lounge |
| 23. Storage Area | 45-48. Offices |
| 24. Electronics Lab | |
| 25. Power/Environmental
Controls | |

Second Floor

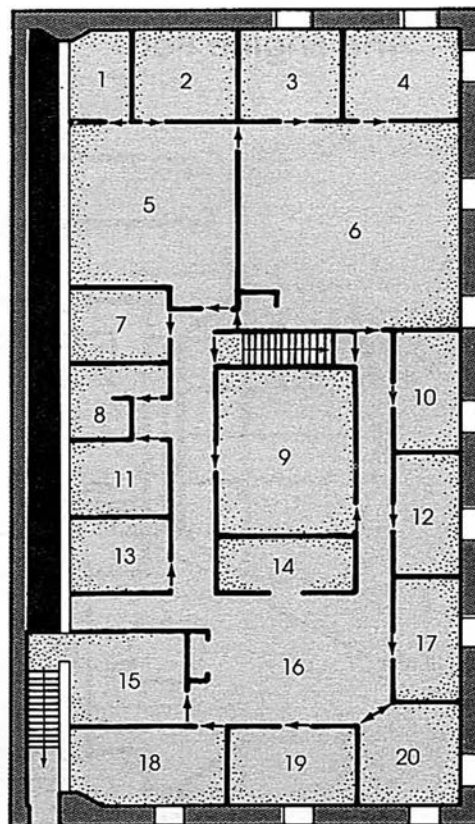

First Floor

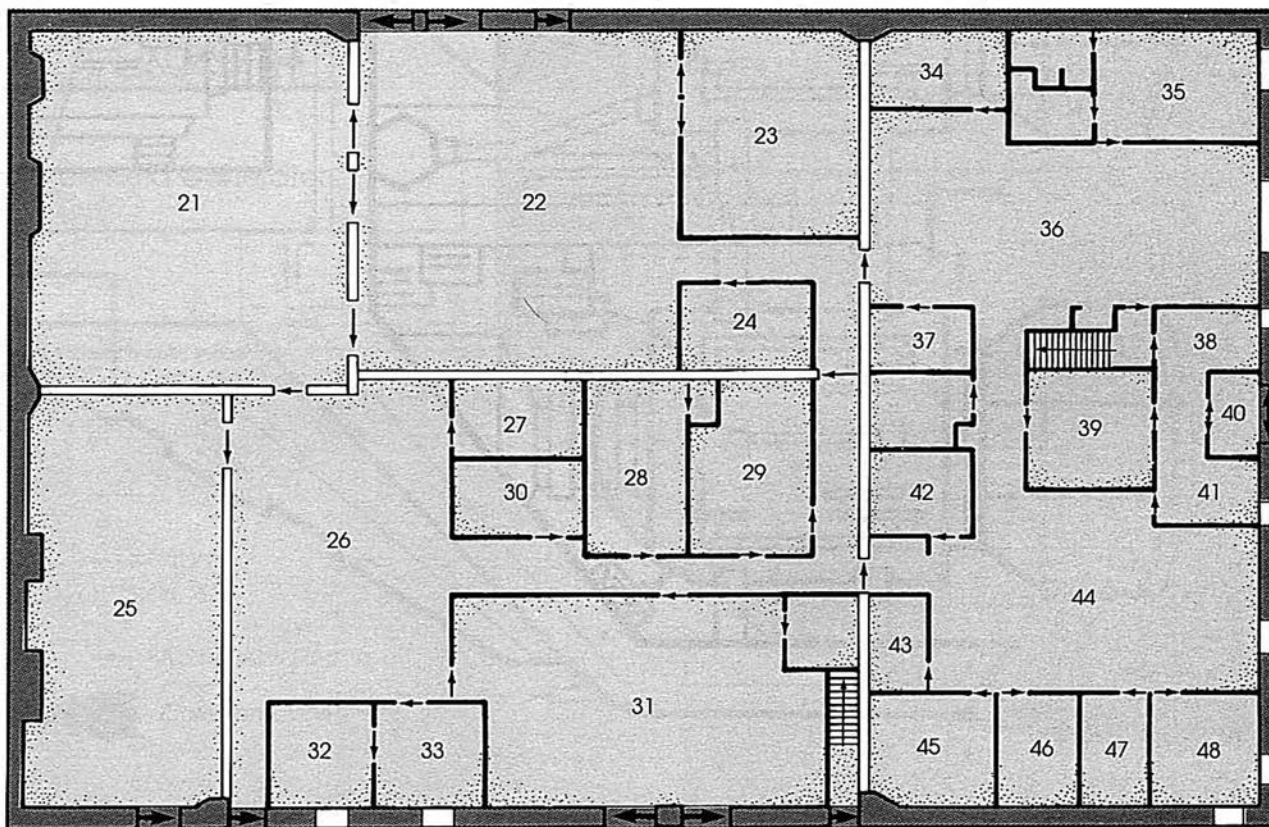

Rosario J. Balcarf

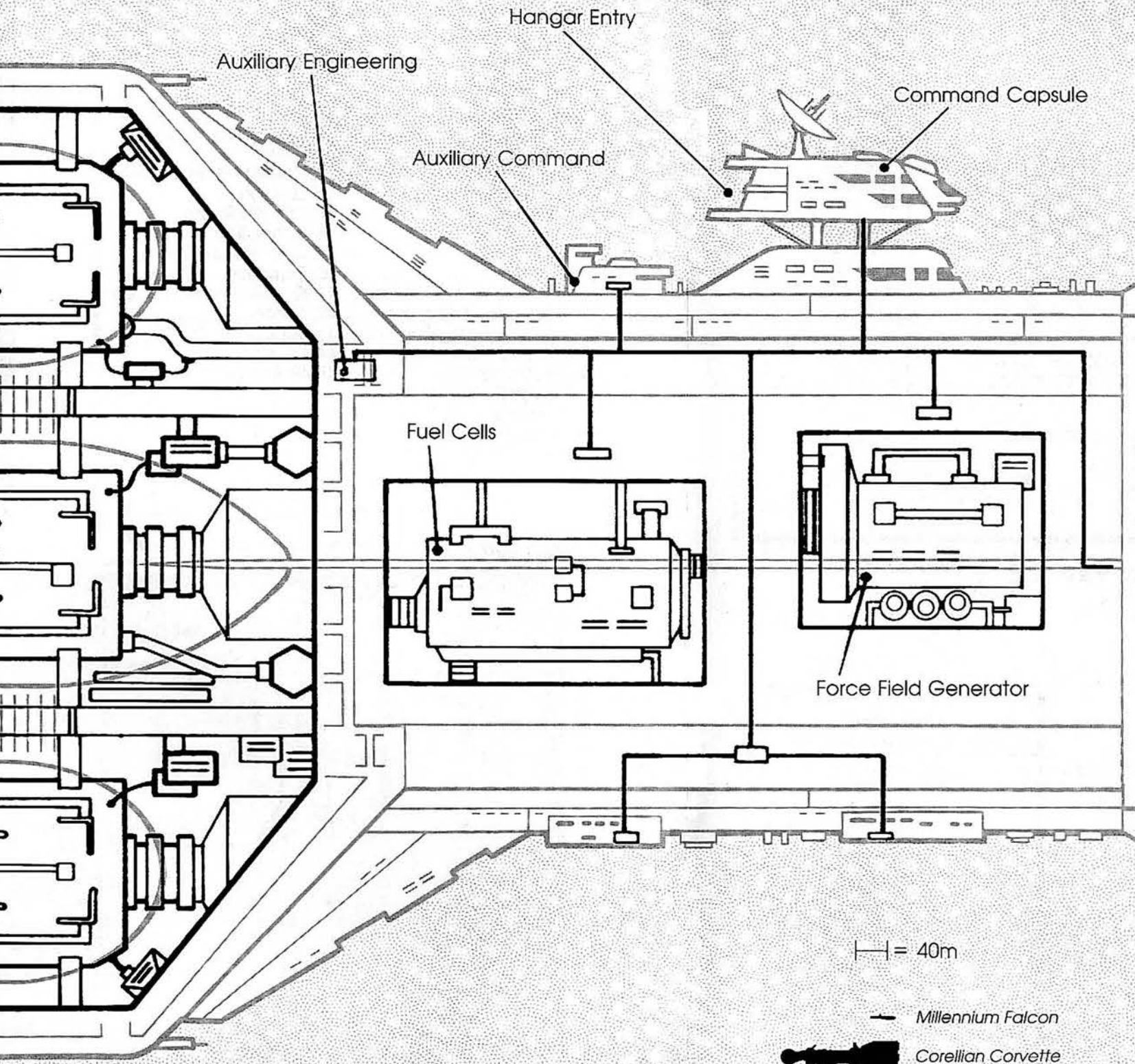

GAMEMASTER MAP: The Big Fight

Solid Machinery and Wiring
 Ventilation Grill
 Ventilation Duct

MAP KEY

- 1-6: REPULSORTUBES
- A: BARRICADE ONE
- B: LOCKED BLAST DOOR
- C: CLOSED BLAST DOOR
- D: BARRICADE TWO
- E: WEAPONS LOCKER
- F: EMERGENCY REPAIR STATION
- G: EMPTY ROOM
- H: VISITING CUSTOM INSPECTOR'S OFFICE
- I: FIRST AID STATION
- J: CAPTAIN'S OFFICE
- K: AUXILIARY ASTROGATION
- L: LUNCH ROOM

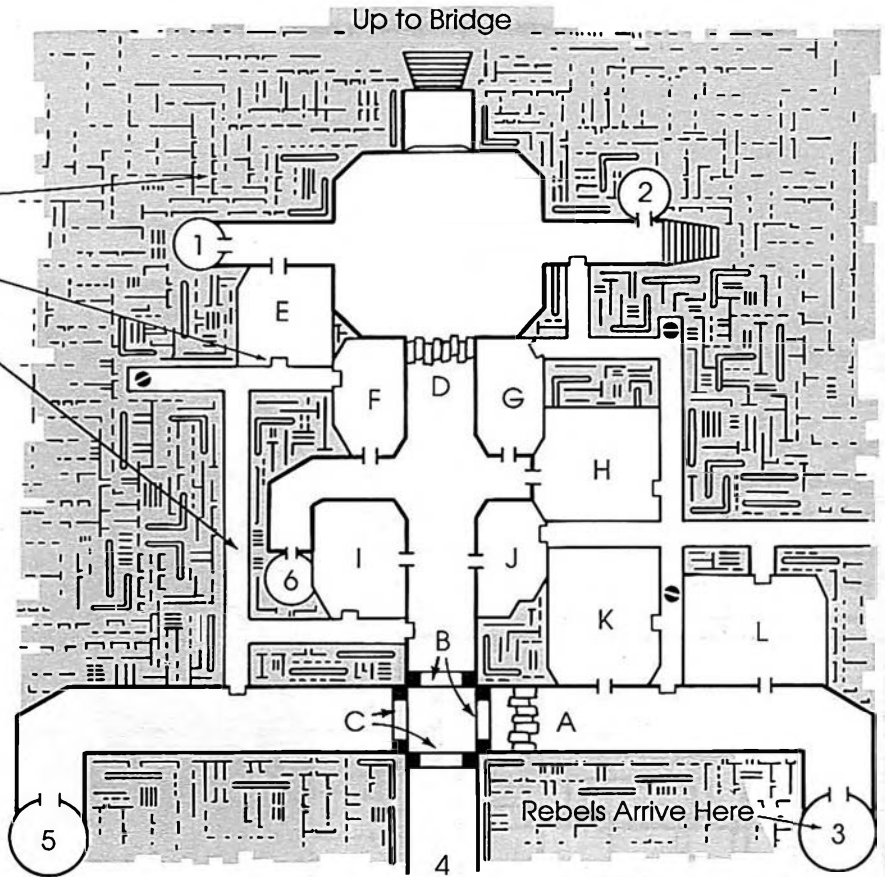

Rosario J. Baldiri

GAMEMASTER MAP: Maintenance Section

Side View

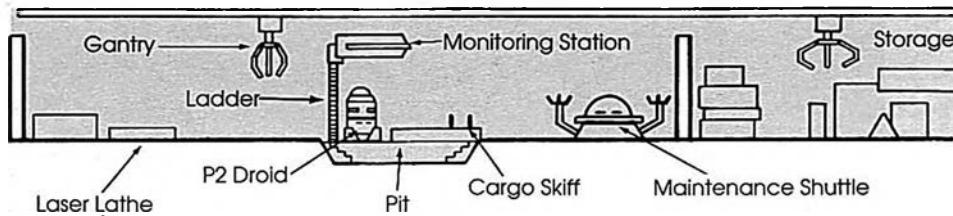

Monitoring Station Computer Repair Top View

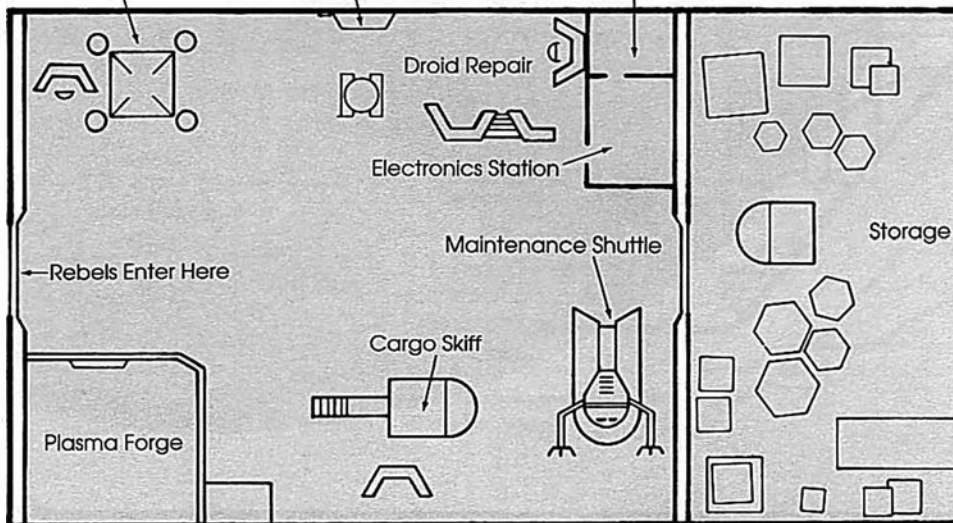

GAMEMASTER MAP: Bridge Section

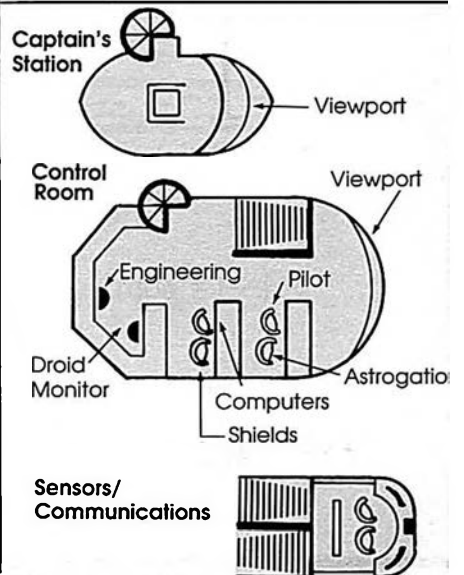
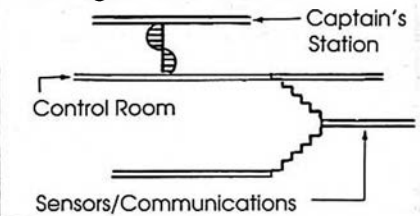

The Command Capsule

—|— = 10m

 Millennium Falcon

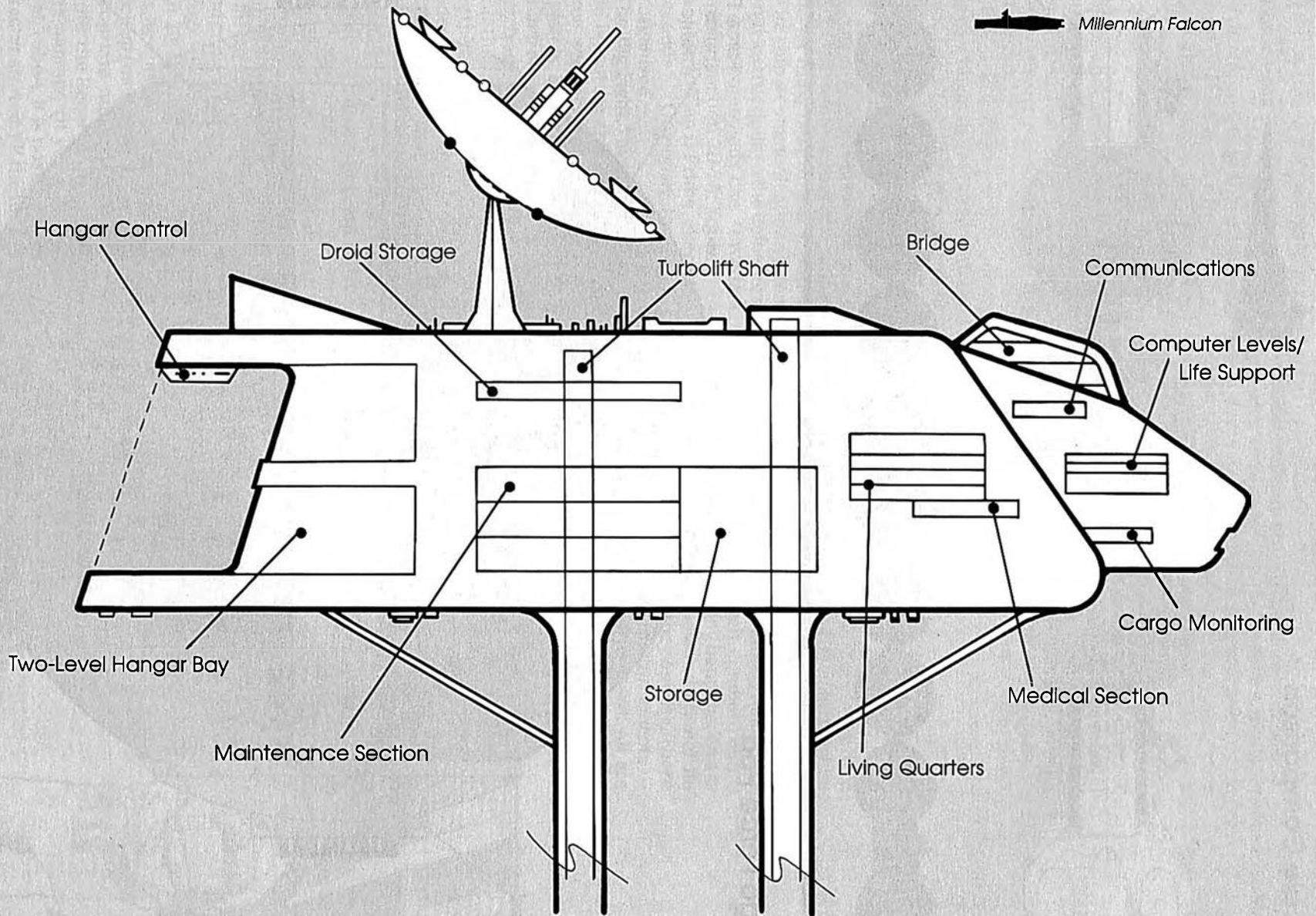

Scale Comparison

Note: Silhouettes of ships are in scale.



Imperial Star Destroyer

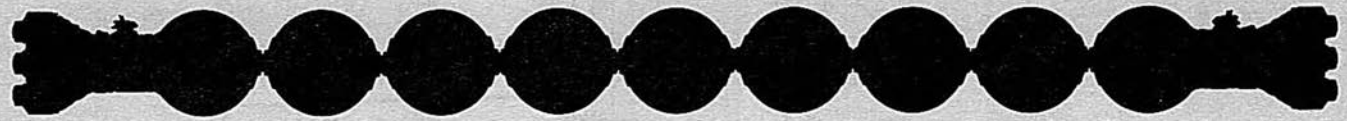
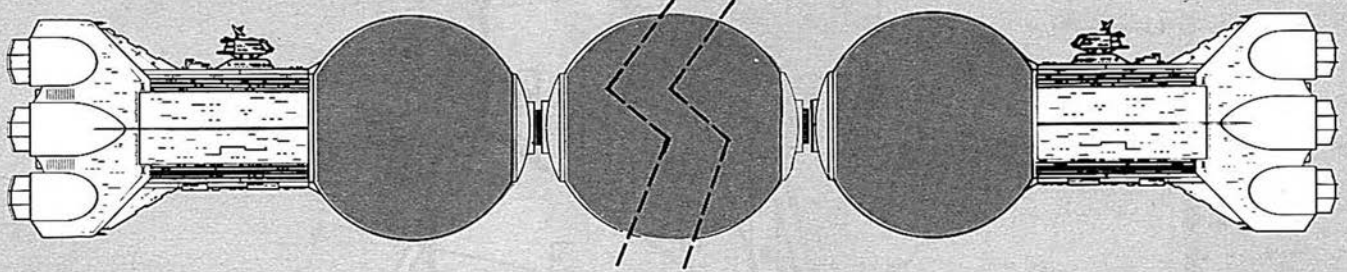

Black Ice

Cargo Force Pod

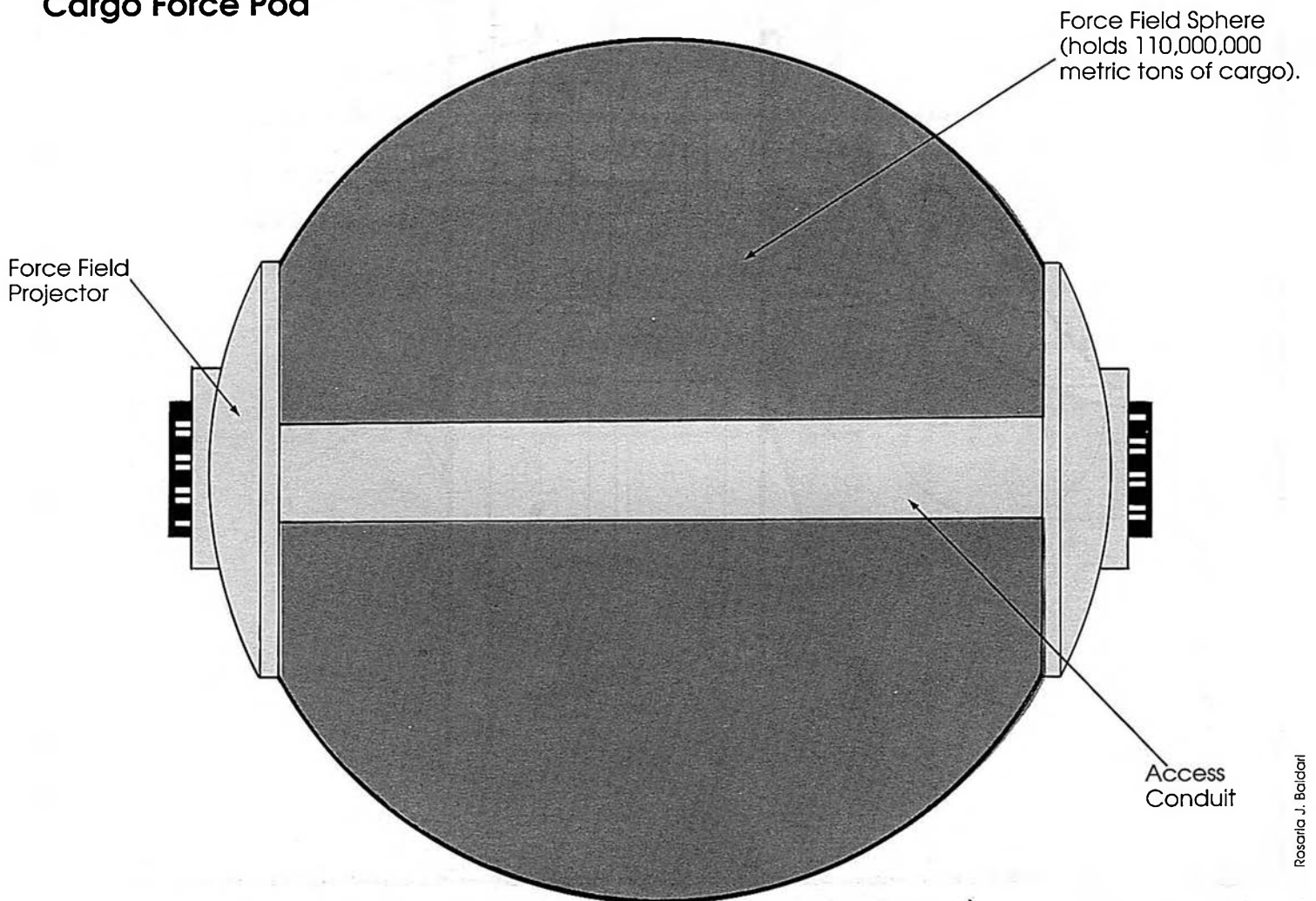

Following are some examples of encounters you can throw at the Rebels as they make their way toward the bridge.

- "... you round the corner at top speed. Unfortunately, so does an R37 Maintenance Droid, carrying a full load of rather sharp-looking wiring. Easy *Dexterity* or *dodge* rolls to avoid 3D damage ..."
- "... your blaster shot fells the Imperial. His personal comlink beeps, and a voice comes from it, saying, 'No sign of 'em here, Lenk. Anything up your way?' Moderate *con* roll to convince the voice nothing is wrong ..."

When the players begin to get bored with the mini-encounters, have the Rebels reach their objective — and run into the main opposition.

The Big Fight

Pick up the tempo as the Rebels approach their objective. Increase the number of sightings of enemies, and let them hear others shouting behind them. The ship's communication system begins blaring out instructions to the defenders, and the Rebels hear commands like, "Invaders sighted at corridor junction 2D-7A; Squad B to junction 5D-7A ... Go to Plan G-Prime, execution in three-zero seconds ..." Obviously, the defenders are getting organized.

The map, "The Big Fight," in the pullout section, shows the layout for the final battle. The defenders, three security guards armed with heavy blaster pistols, are behind barricade one (A), set up just in front of blast doors leading to the bridge. They trade shots with the Rebels for two rounds, and then retreat toward barricade two (D), locking the blast doors behind them (B).

The barricades are hastily constructed of tables, chairs, and assorted items. One and a half meters high, they provide medium cover (+2) for the defenders. The locked blast doors require a Moderate *security* roll to open, or a thermal detonator (Easy *demolition* roll).

Repulsortubes: These tubes are filled with a cushion of repulsorlift energy that allows characters to "bounce" down to the next level without the aid of a lift car. If a Rebel attempts to go to a lower level and come up a different way, let him make a *technology* roll. Subtract whatever he or she rolled from 20; the result is the number of combat rounds he spends on other decks looking for a way back up (minimum of three rounds). Once the appropriate number of rounds has elapsed, roll a die: the Rebel returns to the map at the matching number. (If you roll a "4", the Rebel appears at Tube 4. It is possible to end up where the character started.) If the tube is dam-

aged, there are indentations along the wall that serve as a ladder.

Ventilation Ducts and Grills: .3 meters square, just wide enough for anyone (except a Wookiee) to squeeze into. The black dots represent ducts leading down; Rebels must make Easy *Perception* rolls to spot if they have light, Moderate rolls if they are moving in the dark.

Weapons Locker (E): Contains blasters, blaster ammo packs. Rack for heavy blaster is empty.

Emergency Repair Station (F): Contains manual fire-fighting equipment, axes, spare circuitry, etc.

Visiting Custom Inspector's Office (H): Contains desk, chair, computer, and two security guards.

First Aid Station (I): Bed, medpacs, emergency equipment for minor injuries.

The Defenders' Plan

The three security guards wait at barricade two, where they are joined by two more guards. When the second blast door is breached, they use combined fire against the Rebels to hold them off until reinforcements arrive. Then, when there are at least 12 defenders, they charge.

Reinforcements: There are a limited number of reinforcements available. Each combat round, roll a die. On a roll of 1-3, nothing happens; on a 4-6, reinforcements show up: roll an additional die to see at which repulsortube they appear. There are four men in each group of reinforcements — three crewmen led by a security guard. All are armed with blasters. At most, three groups of reinforcements are available during this battle.



Ending the Battle: The security guards are dedicated, continuing to fight until half their number are incapacitated. Once that happens, however, they will break for repulsortube two. If the Rebels let them go, they head straight for the hangar, where they, along with almost everybody left alive on the ship, board the escape shuttles and make for deep space.

The bridge is currently manned by two very frightened second lieutenants. They will formally surrender the vessel when the Rebels enter.

Shortly after the Rebels secure the bridge, they receive a message from White Team Leader, laconically announcing White Team's success, and asking what is taking the Rebels so long.

C ut-Away to Assault Command

Read aloud:

INTERIOR: REBEL CORVETTE, BRIDGE.
Several Alliance officers watch the battle taking place beyond the viewport. Major Laura Mers checks a monitor, then stares out at Black Ice.

"What could they be doing in there?" *she asks aloud.* "If they don't get that train moving soon, this will all have been a waste of time. We may have caught the Imperials off guard, but they've retaken the artillery bunker and are getting ready to launch the escorts. We're going to be outnumbered very shortly."

"Major," *says a junior officer,* "three lancers and a frigate have just left spacedock."

Mers frowns. "Let's cover *Ice* for a few more minutes, then take us into hyperspace."

Wipe to ...

INTERIOR: BLACK ICE, BRIDGE.

A dditional Rebels

If the Rebels were badly hurt in the battle, you might want to send them reinforcements (that is, replacement player characters) before they make the jump into hyperspace. If so, have a damaged X-wing or two call the Rebels up and ask for permission to hitch a ride on board the huge train. These characters can be temporary or permanent PCs to replace any incapacitated or dead ones.

Into Hyperspace

White Team Leader announces that the forward bridge's controls were damaged in the fire-fight — the Rebels will have to pilot the *Ice* themselves. If they have QT-7 with them, he can talk to the computers and convince *Black Ice* to cooperate (the ship's computers aren't built for logical rationalization, after all); the Rebels need only make Moderate *starship piloting* rolls to operate the train. If QT-7 isn't available, they must figure out the controls themselves (Difficult *piloting* rolls).

Once two Rebels make the roll, *Ice* moves out. The ship is incredibly slow and unweildy, but the Rebels can cold jump the hyperdrive once they clear the gravity well by making a Difficult *piloting* roll (Moderate if they have QT-7). Read:

Space suddenly expands in the familiar pattern — stars blur, colored lights shoot by — as *Black Ice* jumps to lightspeed.

E

pisode Four Chief Engineer Skolos

Summary

In this episode the Rebels discover that the *Ice* isn't as secure as they thought. The ship itself attacks them, and they must battle Droids, security systems, and maintenance equipment to finally win control of the container train. Behind the attacks is Chief Engineer Skolos, a man outraged that "pirates" have hijacked his ship.

After the Rebels win out, they return to Sector HQ with their prize. Suddenly, the ship begins sending out automatic distress signals — alerting the Empire to its location, and the location of the Rebel base.

Chief Engineer Skolos

Thinking that his ship has been hijacked by pirates, Chief Engineer Skolos must wipe out the pirates and return *Black Ice* to the replenishment fleet.

Skolos knows *Black Ice* like the back of his hand — maybe better. He has devised a series of nasty attacks to use against the Rebels. He plans to weaken them, and then destroy them in the maintenance section. He loves his ship and hopes to bring it back intact — which is why he hasn't set the self-destruct or scrambled the cargo as yet.

Broken Contact

This episode begins in hyperspace. Read:

The colors of hyperspace never cease to amaze you. But you only marvel at the streaking lights for a moment before other lights catch your attention. The monitors and indicator tell-tales light up all across the control boards, indicating that there are system malfunctions throughout the ship. QT-7 begins, "We've got some prob — eeyew!" but a crackling charge of energy cuts him short. Then the comlink snaps on and through static you hear:

"Black Team, this is White Leader. We are under attack ... (static) ... Droids ... life support ... (static) ... send help ..."

The comlink goes dead.

Something is happening in the other command capsule and QT-7 has been stunned by an energy surge that has temporarily fused his circuits. Even with the best *Droid repair* rolls, he will be incoherent throughout this episode. The problem is Skolos, of course, trying to take out the pirate groups one at a time. In the next section, we present a number of events that pit Skolos' skills against the Rebels. Use as many as you want, but be sure to have at least two occur at the same time.

Black Ice Events

Using the Shuttle

If one or more Rebels wish to go to aid White Team, the only feasible way to get to the forward enginepod is via the low-powered repulsor shuttle which runs down the conduit at the center of the force balls. A repulsorlift tube leads to the bay where the shuttle is stored. About 20 seconds into the ride, a warning sensor indicates that a force field is in place ahead. The pilot of the shuttle must make a *Moderate repulsorlift operation* roll to stop before crashing into the field, which separates the first ball from the second. Failure causes the shuttle to crash, and while no one is hurt the shuttle is ruined.

The Rebels discover that the force field is in place because the conduit in the next cargo sphere has been breached. Fuel has been spilled into the conduit, making passage impossible. The force field is all that keeps the fuel from rushing into the first sphere.

If any Rebel makes a *Moderate Perception* roll, they notice a Droid moving along the top of the conduit they are in. The Droid is applying a high-powered laser to the metal, seeking to rupture this conduit as well. If the Rebels can destroy it (requires two *Moderate blaster* rolls to destroy) within one combat round, they are safe. Otherwise, the conduit ruptures and they must get out before the tons of fuel crush them.

If the shuttle is working, an *Easy repulsorlift operation* roll gets them out in time. Otherwise they must run for it (a *Moderate Dexterity* roll)

before the first ball's emergency force field falls into place.

Life-Support Malfunction

Any of the Rebels who remain on the bridge must deal with the next situation (although you can have it occur anywhere). An alarm alerts them to a problem, and an *Easy Technical* roll allows one Rebel to decipher the cryptic readings of the life support monitor.

According to the monitor, life-support has been compromised. Carbon dioxide in the air is rising alarmingly throughout the capsule, except in the maintenance and life support sections. The Rebels can try to repair the problem from the bridge by making an *Easy computer programming* roll. While this turns off the alarm and momentarily repairs the problem, compare the Rebel's roll to Skolos'. If the Rebel rolled higher, he realizes that he has to go down to life support to override a second, more devious glitch, which will continue to poison the air at a slower rate. If Skolos rolled higher, no one notices the additional problem until everyone starts getting woozy (minus 1D to all rolls).

In life support, the program is easily repaired (an *Easy* roll).

Sensor Failure

Sensor alarms begin to flash, warning the bridge crew about a large gravity well somewhere up ahead along their projected trajectory. Before the Rebels can get more information, the alarms stop and the sensor monitors go dead. The Rebels can trace the problem to a maintenance ac-

cess tube that connects to the sensor dish (an *Easy Technical* roll). It seems that a relay has been disconnected and must be manually reattached before the sensors can come back on line. Until then, the ship is running blind.

There is no gravity well up ahead. That was a Skolos trick. But the sensors must be fixed if the Rebels are to be sure. The Rebel that makes the trek up the access tube must make an *Easy Technical* roll to locate the disconnected relay, and a *Moderate starship repair* roll to reattach it.

SpyEyes Attack

When any Rebels are off the bridge, they encounter three SpyEyes. These repulsor-driven Droids are small spheres with built-in holocams for remote-viewing. If the Rebels don't try to destroy them (*Difficult blaster* roll to hit, but one hit takes out the fragile mechanicals), the Droids approach, beep apologetically three times, and then explode. Each one does 3D damage to targets within two meters, 2D within four meters, 1D within six meters.

Standard Maintenance

Once most Rebels are running around fixing other things, a Mynock Exterminator Droid named DBX-11 enters the bridge to exterminate the "Mynocks" there. Skolos has programmed the Droid to recognize the Rebels as Mynocks.

Because it normally works in and around the engines, the Droid is heavily-armored. He is equipped with one heavy grasping claw and one built-in blaster. DBX-11 is a bit uncertain about this job because he has never been in the com-

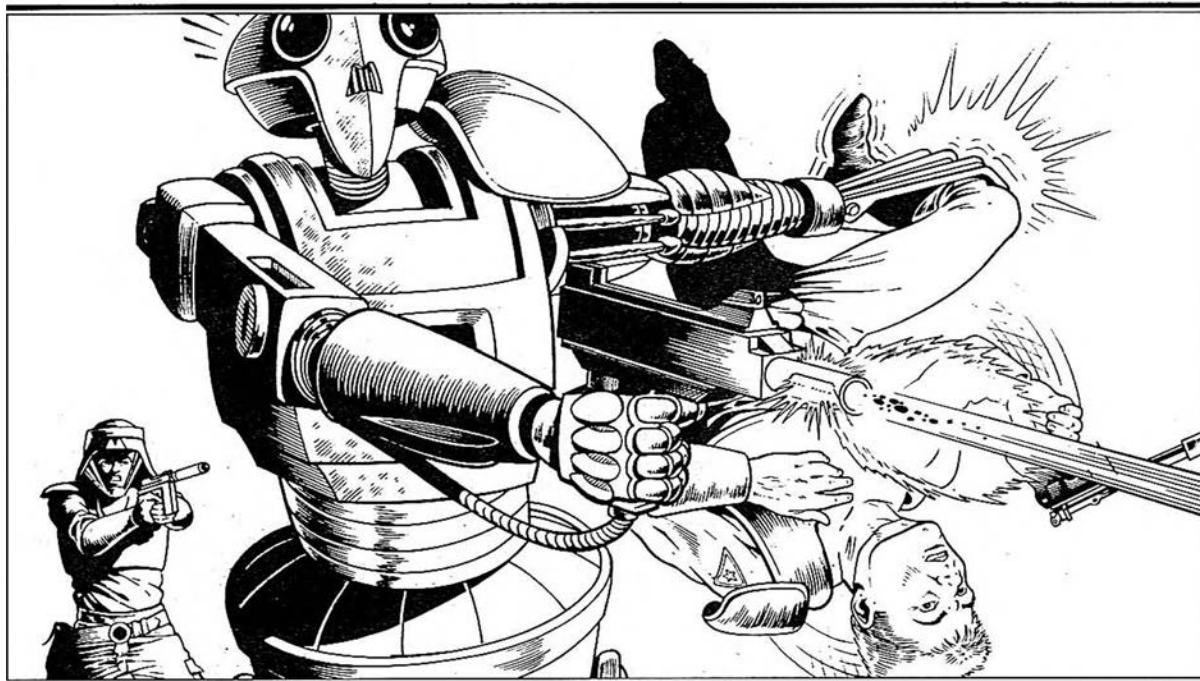

mand capsule before. Also, while his memory circuits clearly define the Rebels as Mynocks, he remembers them looking much different the last time he went to exterminate the pests. Note, DBX-11 has always been programmed via comlink, so he has never seen human beings before. He does have photo- and audio-receptors, though, so he can be reasoned with.

1st Rebel: Blast it! We're not Mynocks! Stop shooting at us!

DBX-11: (*While taking a shot.*) Well, you say so, but how do I know it isn't one of your sneaky Mynock tricks?

1st Rebel: Has a Mynock ever talked to you at all? To say *anything*?

DBX-11: (*Dubiously.*) No ... you're usually too busy chewing on power cables. That's why I have to exterminate you. It's a very important job, you know. The whole ship depends on me! (*Edges around to get a better shot.*) Say, how come you don't have big wings like the other Mynocks?

2nd Rebel: Because we're *not Mynocks!!!* We're human beings!

DBX-11: Oh sure. Tell me another one. Human beings are tiny things living inside comlinks ...

If the Rebels convince DBX-11, he'll tell them the orders to go to the bridge and exterminate the Mynocks came from the voice of Chief Engineer Skolos.

DBX-11: DEX 2D, blaster 4D, melee 3D; STR 4D. Blaster damage 3D, grasping claw damage 5D.

On to the Climax

After the Rebels have experienced a few of the events, Skolos decides to make himself known. On the bridge, alarms go off indicating a fire in the maintenance section. Interior sensors show that maintenance and all the adjoining corridors and levels are engulfed in flame.

If the Rebels ignore the signals, several minutes later, Chief Engineer Skolos' voice rings over the ship's comlinks: "All right, you pirates! I know you're lookin' for me! I'm in maintenance, waitin' for you! Come and get me, you cowardly slugs!"

The Final Battle

The maintenance section is uncomfortably hot. Rebels begin sweating when they reach the outer corridors. Inside, they can hear the roar of some great engine, and the lower rumble of something large moving about. The blast doors slide open as they approach, letting out a powerful wave of heat. If they hesitate, Skolos' voice comes over the ship's comlink once again: "What are you waitin' for, you no good excuse for pirates! If you want my ship, you'll have to deal with me."

The Maintenance Section

Maintenance is a big room, 60 by 48 meters, 12 meters in height. Two sets of large blast doors stand opposite each other, one set leading to the corridor (where Rebels enter), the other leading into the storage section.

There are four main stations in the room: the forge, the lathe, the vehicle repair, and the Droid and electronic repair stations (see map).

Gantry: A large gantry (crane) hangs from the center of the ceiling. It moves on tracks and appears to be able to reach any section of the room. Once the Rebels enter, the gantry attempts to grab Rebels, pick them up, and drop them from a great height. Die codes: grasping 3D (opposed roll vs. Rebel's dodge); Strength 5D; dropping damage 4D.

The Plasma Forge: The forge is used to create replacement components from raw material. It is currently set to maximum heat. Skolos has bypassed the security system and left the forge door slightly open. The forge itself is immune to heat, but the maintenance area is very hot. The flooring near the forge door is beginning to glow bright red. Rebels must make Easy *stamina* rolls every five rounds or take a wound from the heat.

The forge's controls have been tampered with. If a Rebel attempts to shut down the forge, he must roll against Skolos' *Technical* skill. If Skolos wins, the forge doors open fully, sending a tremendous blast of heat into the maintenance area — all Rebels must make Moderate *stamina* rolls or take a wound and collapse from heat exhaustion. A round later, the forge shuts itself off.

If the Rebel wins, he can shut the forge off. Heat persists for 10 rounds, then gradually dissipates.

Laser Lathe: This is a high-precision, high-energy laser used to repair equipment. In standard use, the part is carefully placed on a grid encased in a laser-resistant cowling. The operator sits at the chair and scans the part via holocam, inputting the precise angle, length, and strength of burn into the control pad. Skolos has removed the cowling and now operates the laser from the monitoring station. He holds off firing until a Rebel is on the ladder heading up to monitoring station. Die codes: Laser damage 6D; lathe Body Strength 2D.

Vehicle Repair: Standard vehicle repair equipment scattered about. There is a cargo skiff on jacks over the maintenance pit. An external maintenance shuttle sits in a corner. The cargo skiff merely doesn't work; the shuttle is booby-trapped.

If a Rebel opens the shuttle's hatch, a grenade inside explodes exactly two seconds later (5D damage to person opening door). If the Rebel examines the hatchway before going in, have him make a Difficult *Perception* roll. If he succeeds, he can slam the door or drop to the floor, in which case the damage is only 3D. In either case, the shuttle's controls are completely ruined by the explosion.

Droid Repair: This area contains banks of Droid diagnostic and repair equipment. A variety of Droids in various states of disrepair stand around. When the Rebels enter this area, one Droid rumbles out to attack.

P2-D19 Astromech Repair Droid: An early precursor to the R2 Astromech model, P2s are almost exact duplicates of the R2s, except they are much larger. As the P2s are much simpler than the R2s, it was an easy matter for Skolos to reprogram P2-D19 to attack humans at his command. DEX 2D, laser welder 6D (three meter range only; damage 4D), buzzsaw 5D (damage 5D); PER 2D, search 3D; STR 5D; TEC 4D, starship repair 5D.

Running the Fight

When the Rebels enter, Skolos taunts them, telling them that they had better get the forge fixed before it melts down. The P2 Droid begins moving toward them, and the gantry (which is right above their heads) plunges down onto them. The laser lathe remains inactive until a Rebel reaches the ladder. Skolos is armed with five

grenades. He tosses them out through the monitoring station's window once the Rebels discover him.

Skolos is monitoring the battle through holocams mounted on the gantry and in each corner of the room; he never needs to stick his head out to see what's going on (except momentarily, when throwing a grenade).

Reinforcements: Additional Droids begin showing up six rounds after combat begins — three SpyEye Droids, and then, four rounds later, another DBX-11 (see above).

Talking to Skolos

Skolos is nearly impossible to reason with — all he knows is that the Rebels are pirates who have stolen his ship, and he hates pirates. However, if the Rebels want to try to talk him into surrendering, let them.

Any attempts to *bargain* with or *con* Skolos are Difficult. He cannot be *commanded*. If the Rebels make the rolls and convince him that they are Rebels and not just pirates, he'll grudgingly decide that their attack was a legitimate act of war and therefore it is okay for him to surrender.

If the Rebels do not talk to Skolos, he'll fight to the death.

Leaving Hyperspace

Once the Rebels have defeated Skolos, they have no more encounters on *Black Ice*.

The ship reenters realspace and the Rebels are greeted as heroes. White Team is found on the bridge of the other command capsule — dead from life support sabotage. Then read:

QT-7 finally comes around as his internal repair systems unfuse his circuits. "Hey, guys," he asks, "why are you calling the Empire to come and rescue you?"

As soon as *Black Ice* came out of hyperspace, its emergency distress beacon activated and began broadcasting a shielded tight-beam SOS on all Imperial frequencies. Because of the shielding, Sector HQ does not notice it on normal broadcast scans. The Rebels can shut it down (or have QT-7 do it), but not before the message has gotten out. The Imperials all know exactly where *Black Ice* is — and the secret Rebel base!

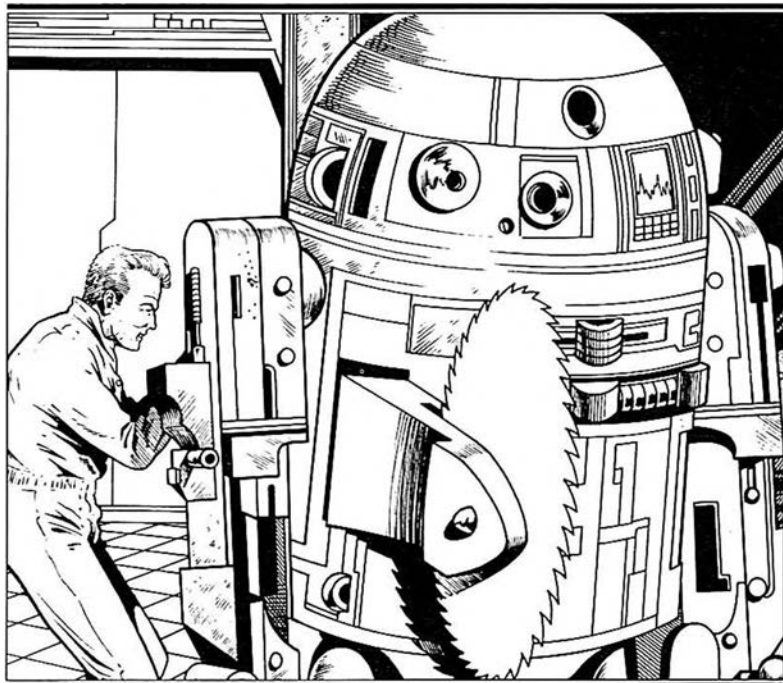

E pisode Five The Blitz

Summary

The Rebels have unwittingly allowed the Imperials to discover Sector HQ's location. Sector HQ decides to evacuate. It will take a week to get everybody off; the Alliance must hold off the Imperials for that long. The PCs take part in the battles, which grow in frequency as the week passes. The episode climaxes with the arrival of a torpedo sphere.

Order the Evacuation ...

Read the following to begin this episode:

You are in special council with the leaders of Sector HQ, in the base deep beneath the surface of Fangol. The discussion has been heated as everyone tries to present their own opinion. After Major Mers has her say, Sector Commander Callus stands up.

"We have heard the opinions and suggestions, but the decision must be mine. We will do our best to hold off any attacks while we prepare to abandon the system. Major Mers, order the evacuation."

Running the Attacks

Following are a series of short sections describing the various Imperial attack waves. Some are space battles, which can be run using either the roleplaying game rules or the *Star Warriors* boardgame. Others take place on the ground, as the defenders attempt to organize the evacuation, man the anti-space weaponry, repair the damage caused by bombing runs, and defeat the stormtroopers who land and attack the base.

Since all Rebel PCs don't have the same skills, obviously some are going to be better suited for space combat and others for ground defense work. If you want, you can let the players run a number of characters each — their primary PCs, and one or two others so that they all can take part in every section of the battle without forcing someone with a lousy *starship piloting* skill to face TIEs. While the battles are taking place, cut back and forth between action in space and on the ground, leaving each section as it reaches a climactic moment.

The action should be fast and furious, and, as the days pass, more and more grim for the defenders

Day One: Probe

A flight of Imperial TIEs arrive in response to Ice's SOS to check the Rebels' defenses.

Star Warriors Scenario

Use the "Dogfight" scenario.

- *Ship Mix*: Use Mix One.
- *Set up*: Rebels begin in set-up area closest to mapedge numbered 1044-4244.
- *Special Rules*: The map is static.
- *Victory*: Imperials gain no victory points for destroying Rebel ships. Instead, they gain points for reaching within scanning distance of the planet (represented by the mapedge hexrow 1044-4244), and then escaping off of the opposite mapedge (and rendezvousing with a waiting frigate for transport into hyperspace).

If an Imperial ship reaches within eight hexes of the planet and then escapes off of the opposite mapedge, he receives that ship's victory points.

S tar Warriors Rules

The following sections contain a number of battle scenarios for use with the *Star Warriors* starfighter combat boardgame. Each section describes the scenario and lists any special rules; pick ship mixes to fit the number and skill of your players.

Note that victory conditions may be slightly different than in standard *Star Warriors* games, as described below. (Remember that, as gamemaster, you should be more interested in producing a fun, interesting game for your players than in winning!)

Survival: Since they are fighting around their base, the Rebels have a greater chance of survival than in a normal *Star Warriors* scenario. When a PC's ship is destroyed, he must make a *survival* roll of difficulty 10 to survive until picked up by a retrieval ship.

RPG Starfighter Combat Rules

The battle scenarios can be played using the starfighter combat rules found in the *Star Wars* rulebook (pages 61-65) and the *Star Wars Rules Companion* (pages 17-21).

If a ship reaches within six hexes and then escapes, the Imperial player receives *twice* that ship's victory points.

If a ship reaches within four hexes and then escapes, the Imperial player receives *triple* that ship's victory points.

RPG Scenario

Three Rebel X-wings take on two TIE fighters and two TIE Interceptors. The fight begins at long range. TIEs will move to within close range of the Rebels; three TIEs will engage with the Rebels, and the fourth will go scout the planet. Rebels cannot give chase until *all* the attacking TIEs are destroyed or driven off.

- **Victory:** If TIEs can keep Rebels engaged for six rounds, the scout TIE has time to fly past the planet and back into space. Imperials win.

If Rebels destroy opponents within four or five rounds, they can chase the scout (starting at long range); if in three rounds or less, the chase starts at medium range. Once the chase begins, Rebels have five rounds to destroy the scout before it reaches the protection of the frigate. If Rebels destroy the scout, they win.

On the Ground

Rebels not in starfighters are put in charge of the southern sector of the base. This area contains living quarters for dependents of Rebel soldiers and commanders, and one of the base's primary anti-air batteries. The PCs have 20 soldiers under their command, each armed with blasters. There are also five blaster rifles, one repeating blaster, and a bacta tank and an unlimited supply of medpacs (in the infirmary).

The Rebels' primary obligation is to protect the 200 civilians under their care. Next, they must keep them under control, ensuring that the evacuation is orderly and unpanicked. At the moment, this isn't difficult, but later, once the stormtroopers arrive, it may be.

Rebel Troopers (10): DEX 3D, blaster 3D+2; STR 2D+2, brawling 3D. All other skills, 2D.

Rebel Gunners (5): DEX 3D, blaster 3D+1, heavy weapons 4D (*Star Warriors* gunnery skill 5D); STR 2D+2. All other skills, 2D.

Rebel Techs (3): TEC 3D, demolition 4D, computer programming/repair 4D, security 4D. All other attributes and skills, 2D.

Medics (2): Medicine 4D. All other attributes and skills, 2D.

Day Two: Moon Shot

Heavy Imperial attacks occur. Their objective: destroy base's communications satellite — the artificial moon.

The Imperials will make three runs during this period. If the Rebel PCs keep their opponents from hitting the moon for the first two runs, some time during the third, another defensive sector will collapse, allowing other ships to break through and destroy the moon.

Attack on the Moon

Sector HQ is connected with the outside galaxy through an artificial moon stationed in fixed orbit above the base. The Imperials' first job is to knock out this moon, seriously disrupting the Rebels' communications.

Star Warriors Scenarios

These are dogfight scenarios.

- **Ship Mixes:** Use mix one for first battle. See below for following battles.

- **Set Up:** Rebels and Imperials set up in same areas as previous. In addition, place the moon marker in hex 2639.

- **Victory Conditions:** Imperials win if they destroy the communications net on the moon by the third run. If not, Rebels win (though the communications net is destroyed anyway, by other Imperial ships). If the net is destroyed on the first or second run, there are no additional attacks against it — instead, go directly to the attack against the base, below.

- **Special Rules:**

Destroying the communications net — when firing at the moon, the usual modifiers to the difficulty number apply. Obviously, the moon cannot perform maneuvers, so only the ship's maneuvers will affect the number.

When the moon is hit, use the "Front Quarter" line of the Fire Table. The moon is destroyed once it receives 10 or more body points, or the attacker rolls 14+. Ignore other results.

- **Force Mix on Second and Third Battle:** The Imperials receive the same ships as they did in the first scenario. The Rebels, however, are beginning to run out of ships. The Rebels get all undamaged ships from earlier missions; to repair damaged ships or replace destroyed ships, roll on the appropriate tables in the accompanying boxes.

Roleplaying the Attack on the Moon

First battle uses same force mix as previous battle. The fight begins at long range. TIEs will

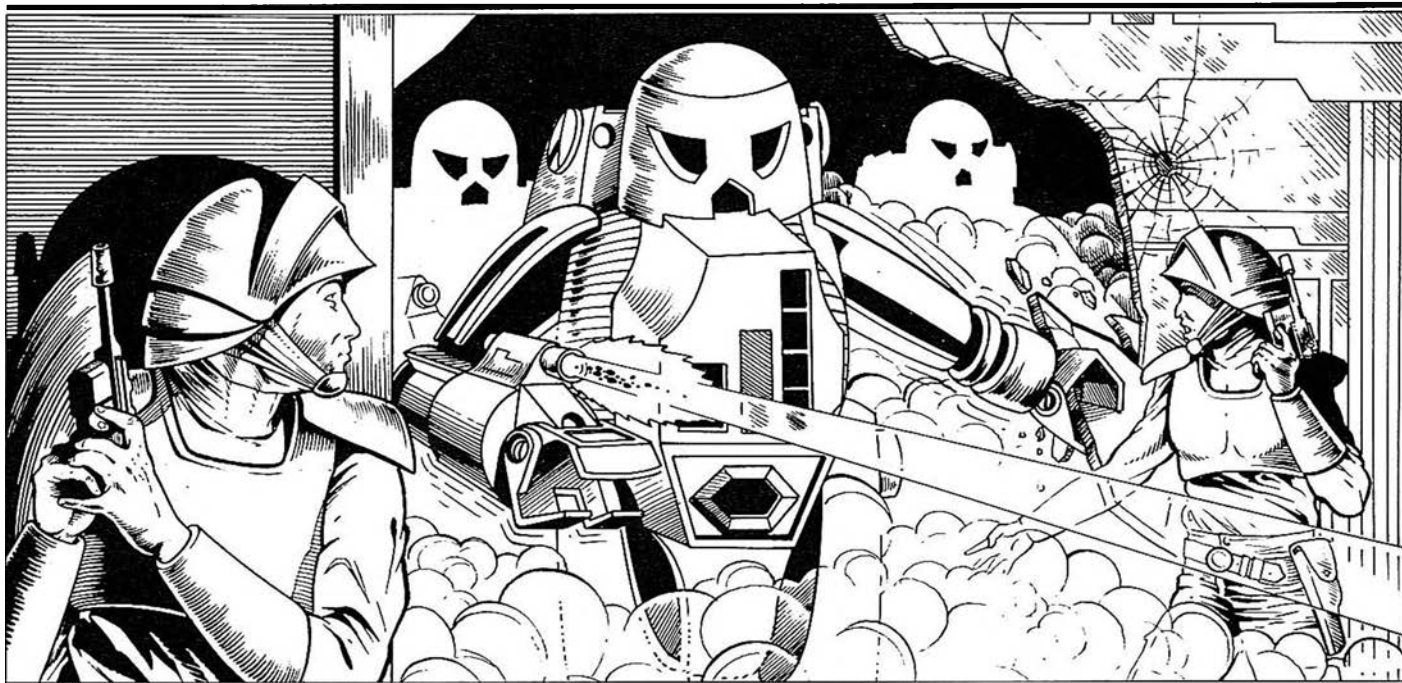

move to within close range of the Rebels. As before, ships pair off, and excess attempt to reach and destroy the moon. Moon is four rounds past the Rebels; if TIE reaches moon, Difficult roll to hit; attacker must roll a 20 for damage on his 5D laser cannon to destroy moon.

Use the repair and replacement tables above between scenarios.

Day Four: Sneak Attack!

A commando squad of four spacetroopers attacks the base, slipping in on a glider and using the planet's mist to disguise their approach. Landing several kilometers away from the base, they sneak up and attack the sector commanded by the PCs. The spacetroopers burn through a corridor ceiling and immediately head toward the command section of the base. The Rebels must hold them off until reinforcements arrive—at least 10 rounds. The Rebel soldiers under their command will help as best they can, but the civilians are useless.

Zero G Assault Spacetrooper: DEX 1D, weapons 3D; MEC 3D, starship piloting 4D, starship gunnery 4D; STR 2D (5D for damage purposes), brawling 3D. All other attributes and skills 2D. Weapons: concussion grenades (damage 5D), stun grenades (stun damage 5D), mini-proton torpedoes (damage 6D), blaster cannon (damage 6D), laser cutters (damage 3D).

Day Five: The Ground Assault

Once the base's communications are destroyed, the Imperials launch an attack against the base. The attack is hampered by the mists of Fangol, cutting down visibility drastically. At this point, the Rebels on the ground join in on the action, as they operate the base's guns, and later, fight the stormtroopers who infiltrate the base.

Ship Repair Table

Have the pilot of a damaged ship roll on this table between battles. If the pilot makes a Moderate *starship repair* roll, he adds +1 to the roll.

Die Roll	Star Warriors Result	RPG Result
1	No time to repair damage. Ship flies as is.	No time to repair damage. Ship flies as is.
2	3 units damage repaired.	1 level damage repaired.
3	4 units damage repaired.	1 level damage repaired.
4	5 units damage repaired.	2 levels damage repaired.
5	6 units damage repaired.	2 levels damage repaired.
6+	All damage repaired.	All damage repaired.

Units of Damage (Star Warriors): For each unit of damage repaired, player may repair a point of body, engine, gun, lateral control, power, or stabilizer damage.

Levels of Damage (RPG): For each level of damage repaired, improve the ship from severely damaged to heavily damaged, from heavily damaged to lightly damaged, or from lightly damaged to fully operational. If roll repairs two levels of damage, a severely damaged ship becomes lightly damaged, etc.

Ship Replacement Table

A player whose ship is destroyed can roll on this table after each battle.

Die Roll	Star Warriors Result	RPG Result
1	A-wing: 4 hits.	A-wing: severely damaged
2	A-wing: 3 hits.	A-wing: heavily damaged
3	Y-wing: 3 hits.	Y-wing: heavily damaged
4	Y-wing: 2 hits.	Y-wing: lightly damaged
5	X-wing: 2 hits.	X-wing: lightly damaged
6	Fresh X-wing.	Fresh X-wing.

Hits: For each hit, roll two dice on the Fire Table (modified power number of 0). Reroll any results which would destroy the ship. Pilot cannot roll on the Repair Table until after the battle.

Star Warriors Scenario

This is based upon the "Ground Attack" scenario. The attack occurs in three waves.

• **Force Mix:**

Imperials: The Imperials receive two TIE Interceptors and two TIE Fighters for the first wave, two Interceptors and two TIE bombers for the second, and three Interceptors and three *Lambda*-class shuttles for the third wave.

Rebels: The Rebels receive a standard base (see *Star Warriors* section 29.2). The "Target Marker" represents an entry point into the base. The Rebels also receive the remnants of their ships from the last battle. As there are several hours' delay between the end of the previous missions and the beginning of this one, they have time for two rolls on the repair table, or, if necessary, one roll on the ship replacement table and one roll on the repair table. They still get only one roll on either table between missions, however.

• **Victory:** The Imperials are attempting to land an assault force at the base. The first two waves of the attack are supposed to soften the target up enough so that the third, containing the shuttles with the assault force, can land at the entry point (the target marker). The Imperials receive no victory points for destroying Rebel targets; instead, they receive 20 points per shuttle which lands (ends its turn) in the target hex. The Rebels receive victory points as normal.

• **Special Rules:**

Gunners: The Rebel base is manned by the ground-based Rebel PCs and gunners under their control. PCs use their *heavy weapons* skill +2D for their guns' targeting computer as their *gunnery* skill; the gunners' score is 3D (+2D for targeting computer). An individual gunner can control a single or double turret at no penalty; he can remote-control multiple guns, with a penalty of minus 1D for each additional gun under his con-

trol. Note which guns the PCs control on a separate piece of paper; also note which guns they occupy.

Destroyed Guns: When a gun is destroyed, roll a die: On a 1-2, the gunner is unscathed; 3-4, he is wounded; 5, he is incapacitated, and on a 6 he is mortally wounded. If the gunner makes a *Difficult dodge* roll, he can reduce his injury roll by one. Naturally, if the gun was remote-controlled from another turret, the gunner is unharmed.

Repairing Guns: Each PC in the ground force, plus the techs, may attempt to repair destroyed guns between battles. Each destroyed gun requires a *Technical* roll of 16; up to three characters can combine on this roll. There is time for one repair roll from each character between battles (however, some of the PCs may be otherwise engaged; see below).

The Mist: The mists of Fangol make it very difficult to fire guns with any accuracy at all. Add 5 to all difficulty numbers.

The Ground Assault: RPG Scenario

These scenarios are rather difficult to run using the standard roleplaying starship combat rules, particularly when the ships make their runs against the base. Therefore, we have modified them somewhat to handle the unusual circumstances.

Run the ship vs. ship battles as normal, and assume that only Imperial ships not engaged with Rebel ships can make attack runs against the base. When ships attack the base, the gunners make opposed rolls against the Imperial pilots each round (*heavy weapons vs. starship piloting*). Actions are taken for the round in order of the rolls, highest roll first. The shuttles start at long range to the base and close every round (until destroyed or disabled). The round after a shuttle reaches short range, if it is not destroyed, it lands at the base. See "The Final Battle" for what happens next.

Remote-control gunning and gunner survival

Anti-Atmospheric Guns

Sector HQ is protected by a series of Comar G-001 Tracker light and medium surface-to-air defense guns. The guns' statistics follow; medium gun stats in parentheses.

Scale: Starfighter

Body: 1D (1D)

Range: *Short:* 10 to 300m (20 to 600)

Medium: 301 to 1,500 (601 to 3,000)

Long: 1,501 to 8,000 (3,001 to 16,000)

Fire Control: 2D (3D)

Damage: 3D (4D)

are handled as in the *Star Warriors* scenario.

- *Force Mix*: The ground-based Rebels are equipped with three double-turret medium lasers and six single-turret light lasers. The Imperial and Rebel ship force mix and reinforcement rate is as described above under the *Star Warriors* scenario rules. Between battles, Rebels roll on the replacement and repair tables, above.

Other Occurrences

Here are some additional things you can throw at your players.

- Use *command* skills to stop a panic.
- Battle a fire in the base.
- Use *demolition* skills to disarm an unexploded proton bomb dropped by a TIE bomber.
- After the medical facilities are hit, a Rebel volunteers to take the incapacitated doctor's place until a substitute arrives.

The Final Fight

The Rebel defenses have been softened up. There are virtually no Rebel starfighters left undamaged, and many of the base's anti-atmospheric guns have been silenced. Though they, too, have just about run out of starfighters, the Imperials have one trick left: they launch their ground troop invasion.

If the Rebels can defeat the invading troops, they are almost certain to be able to evacuate before the Imperials can mount another invasion; if not, they are lost.

The Attackers

The attackers are standard stormtroopers, hitting the base from attack shuttles. For each shuttle the Imperials succeeded in landing in the last scenario, 15 stormtroopers attack the Rebels' sector. If the Rebels failed to destroy any of the shuttles, they must face 45 stormtroopers. While this is occurring, several hundred others hit other parts of the base, but the Rebels will only face those assigned to them and will determine

the overall outcome by their success or failure (as go the heroes, so goes the war). If the Rebels stopped all of their shuttles, then 15 stormtroopers from a different sector break through to attack them.

The stormtroopers are planning to enter the base and proceed as quickly as possible to the gunnery section of the Rebels' sector and disable the guns. If they are successful, they will immediately notify Imperial command, in orbit above, to reroute another shuttle to this sector — the Rebels will face another 15 stormtroopers in 12 combat rounds.

The Defenders

The Rebels have whatever of their initial ground force survived the space battles. In addition, the Rebels flying the starfighters may arrive. At the beginning of each round following the third round of combat, roll a die: on a 6, the starfighting PCs arrive.

If sorely pressed, the Rebels may request reinforcements. At the start of each round, roll two dice: on a roll of 11 or 12, five Rebel troopers arrive. Only five troopers are available — after that, the Rebels are on their own.

Aftermath

The defenders have held — just barely. In 24 hours, Rebel freighters will take off carrying the last of the sector command, and in mere weeks, they will have another base set up on a different planet. Everybody congratulates themselves on a job well done.

Suddenly, a report comes in from a starfighter on picket duty in space. Read:

“Something's just come into the system ... I can't quite figure out what it is; my sensors must be malfunctioning or something ... I'll go in for a closer look ... Oh no! It's a torpedo sphere! Heading this way, ETA three hours!”

Sector Commander Callus shakes his head. “We almost made it, too. Prepare to surrender.”

E

pisode Six
No Surrender**Summary**

The Imperials have gotten a torpedo sphere into the system. It will be in position to begin bombarding the Rebel base in three hours. The Rebels won't be able to complete evacuation of the civilians for at least another 24 hours. The Rebels have nothing which can touch something that big — the only course open to them is surrender. Or is it?

Someone — hopefully the Rebel PCs — suggests ramming the sphere with *Black Ice*. Rebel High Command likes the idea — but, as it is tantamount to suicide, asks for volunteers. The heroes volunteer (or Mers volunteers them).

A Hero's Death

Sector Commander Callus, unwilling to submit the civilians at the base to death, considers surrendering his post. This will be a terrible blow to the Rebellion for a number of reasons — with the loss of Sector HQ, the entire sector organization is imperilled. He calls a meeting of his top advisors and operatives to discuss the situation.

Read aloud:

Commander Callus, looking grim, recounts the situation:

"The torpedo sphere is less than three hours away. We've got a few damaged starfighters and a half-dozen virtually unarmed freighters. Nothing we have will even put a dent in the sphere.

"When the sphere arrives in orbit, it will reduce the base to slag in mere hours. The planet's atmosphere is toxic; even with breath masks — which we don't have enough of anyway — people exposed to the atmosphere will die painfully.

"As I see it, our only choice is to surrender. Otherwise, the several hundred civilians still here will die, and to no purpose."

Someone stifles a sob. The commander rubs the back of his head helplessly.

"If anyone has any bright ideas, now is the time to share them."

Now is the time for the Rebel PCs to speak up. Look at them expectantly. If they don't, sigh and then read the next section:

Major Lawra Mers raises her hand. She looks calm and collected, as always, but you can see a glitter of excitement in her eyes. You know that expression well.

She casually rises from her seat and strolls over to the holodisplay showing a view of the planet.

"I wonder," she says, pointing at *Black Ice*, floating serenely in orbit around the planet, "what would happen if the *Ice* were to — somehow — plow into the torpedo sphere ..."

I Want Six Volunteers — You, You, You, You, You, and You.

The Rebel heroes volunteer to pilot *Black Ice* in a kamikazi attack against the torpedo sphere. They *have* to. They are the only ones on the planet who have been aboard the ship, and the only ones who have any experience piloting her. And besides, they are the *heroes*.

Are they really going to let someone else take the risk — and earn the glory?

If they don't speak up immediately, sigh once more and shake your head. Commander Callus asks for volunteers. Everyone in the entire room immediately does so. Look expectantly at your players.

This is their last chance. If they still do not volunteer, the adventure is essentially over. Six other Rebels, under the command of Lawra, man the *Ice* and successfully ram the torpedo sphere, though at the cost of their own lives.

Go to the final section, "Epilogue." Give out the listed number of skill points. However, under the circumstances, the Rebels earn no Force points. They don't deserve any.

If the Rebels do volunteer, but there are none left with a decent *starship piloting* skill, they are assigned to accompany a team of two non-player character Rebels, Rewen Porrot and Lucas M'benka, who have *piloting* skills of 5D+2 each, and all other skills and attributes of 2D.

The Plan

Commander Callus' plan is as follows:

- First, they have to smuggle the Rebels aboard the *Ice*. If the Imperials spot this happening, they might figure out what the Rebels are up to, and destroy the *Ice* well before it is within range. The remainder of the Rebel fleet will sortie out and engage the sphere, diverting attention from the *Ice*, and employing all manner of jamming equipment to jam the Imperial sensors. The Rebels board *Ice*, with Lawra Mers and QT-7 along.
- Once on board the ship, the Rebels will wait until the torpedo sphere is in position to bomb the base. Then — and only then — they will power up the engines and slam the ship into the sphere. The *Ice* is very, very slow, and very vulnerable to enemy fire. They must wait until the torpedo sphere is close to the planet, slowed by the planet's gravitational pull, and quite close to the *Ice*, if they are to have any chance to ram it.
- Once the ship is on a definite collision course with the sphere, the Rebels are to evacuate.

Opening Moves

The Rebels are due to leave in an hour. Let them make any final preparations — healing, Force-use, equipment requisitions, final farewells, etc. After they are finished, read aloud:

The time has flown by. All of the preparations are complete; the greatly outnumbered "attack" fleet has flown off to confront the behemoth. In a few moments, it will be your turn. Major Mers, carrying QT-7, is waiting for you at your shuttle. "I hope you have room for two more," she says, a twinkle in her eye.

The Rebels board the shuttle and fly up to *Black Ice's* command capsule.

Rebels on *Ice*

The Rebels reach the bridge to begin prepping the ship for its last voyage. They have been warned not to power up, or to attempt to communicate with anyone outside of the ship; the Imperials may notice the power fluctuations.

From what they can read on the ship's passive sensors, the Rebel fleet has been pounded by the Imperial corvettes escorting the torpedo sphere; the Rebels have fled into space, most of the corvettes in close pursuit. The remainder are stationed fore and aft of the sphere, a cloud of TIE fighters providing additional protection.

Duty Stations

The Rebels should decide which stations they will take on the bridge. Each section's functions are described below:

Captain's Station: Can control any of the functions of the other stations, except sensors.

Pilot's Station: Pilots the ship.

Astrogration: Used only in hyperspace travel.

Computer: Can be used as a flight predictor, to help pilot. Can also control the shielding or operate the ship's sensors (but at minus 1D to operator's *Technical* skill). If QT-7 is on board, add 1D to all computer operator skill rolls.

Shields: Operates the two sets of ship's shields.

Engineering: Used to engage the ship's engines; can reroute power to and from the ship's shield and propulsion units.

Sensors and Communications: Can be used to operate the ship's sensors. Also useful for communicating with other ships.

The First Test

To determine when to begin their run, the Rebels must accurately chart the torpedo sphere's course and decide exactly when to start their ship's engines, how long they will take to engage, and what velocity they will need to attain to achieve maximum damage upon impact.

Call for a Moderate *Technical* roll from the Rebel operating the sensors. The sensor and computer station operators can combine to make this attempt. They can make the attempt as many times as they want, but each attempt takes five complete rounds. (The amount of time they take is not important, but don't let the Rebels know that: keep them nervous.) Success will tell them exactly what the sphere's present course and speed is and when it will be in the best position to be rammed.

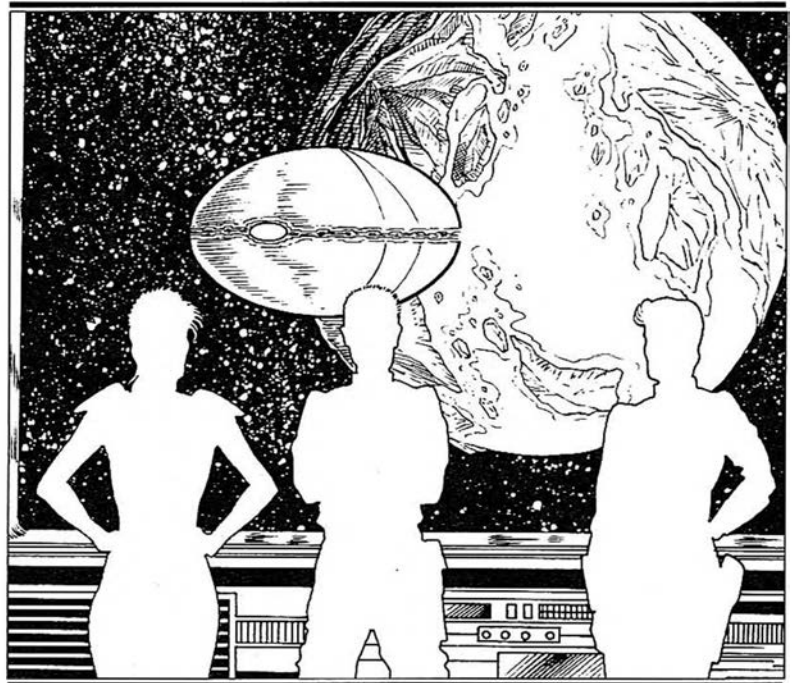

Once the roll is made, call for a Moderate *Mechanical* roll from the engineering station or captain's station (at minus 1D to the captain's roll). The two stations can combine on this roll. Success tells the Rebels how long it will take to power up the engines and begin moving — eight rounds to be safe, six rounds if they want to take a chance. It can be done in four rounds if the Rebels are desperate.

After they know this, the Rebel piloting the ship must make an Easy *piloting* roll. Success tells him that, given what they know of the two ships' speed and maneuverability, to be sure of hitting their target, the Rebels will have to begin their run just as the sphere is reaching the closest point — if they leave too soon, the sphere will be able to sidestep the approaching train; if they leave too late, the sphere's orbitary path will take it out of range. (Failure on this roll still gives the pilot information that appears correct, but it adds to the difficulty later on.)

In either case, once they commit and begin their attack run, the Rebels cannot afford to divert from their course by even a meter — the ship is so unwieldy, it will be nearly impossible to make course corrections in time. No matter what the Imperials throw at them, they have to stay on course.

The Rebels will have only one chance — if they fail, the corvettes and TIE fighters will blow them away before they can possibly recover.

The Second Test: Tough Decisions

Many long, tense moments pass as the Imperial fleet approaches the planet. Several TIE fighters and Interceptors circle *Ice* curiously, but seeing nothing of interest in the "dead" vessel, soon return to their stations near the sphere. The chronometer ticks off the seconds — soon the sphere will be in position. Read:

This is it. The moment approaches when you will begin your final run. There is little time for anything but total concentration on the job ahead. Slowly, the huge torpedo sphere fills the sky, all but eclipsing the sun.

There are two things you must decide now: the acting engineer knows that it will take some time to warm the engines enough to safely engage the ship's shielding and propulsion units — eight rounds to be safe, six rounds if you want to take a chance, and four rounds if you're crazy. You also know that the longer you take, the more time you grant the Imperials to discover what you are up to and either change course or blow you out of space. The engineer must decide how quickly he is willing to push the engines.

The second choice is for the pilot: where do you hit the sphere? You can wait for your best shot, giving the torpedo sphere an opportunity to begin bombarding the base, or, if you're skilled enough, you can hit them earlier, before they can line up a shot on the base.

These are difficult choices, but you can take some comfort from the thought that, if you fail, you won't live long enough to regret it. So what's your plan?

Give the Rebels a few minutes to discuss the situation. Once they have decided upon a course of action, go to the next section.

The Third Test: Starting the Engines

The engines can be started with a *Mechanical* roll by a Rebel at either the engineering station or the captain's station (though at minus 1D to the captain's roll). The difficulty of the roll is dependent upon how quickly the engineer wishes to get the engines up and running: eight rounds is an Easy test; six rounds is a Moderate test, and four rounds is a Difficult test.

If the Engineer fails the test, the ship's engines cough — and then stall. The engineer may test again next turn to restart the engines, but the new test is at +2 difficulty.

The Fourth Test: Piloting

This is where the ship's pilot sets the course to collide with the torpedo sphere. The *starship piloting* test is Moderate if the pilot decided to wait until the torpedo sphere was in the best position, and Difficult if the pilot wants to ram the sphere before it has an opportunity to begin bombing the base. (Raise the difficulty one level if the pilot failed the roll in the first test.)

The test may be attempted from the pilot's station or from the captain's station, or the two may combine actions.

If the test is failed, it may be attempted repeatedly, but each failure incurs an +3 to the difficulty number.

The Fifth Test: Shielding

Once the *Ice's* engines fire up and it begins moving toward the sphere — or earlier, if no one successfully completed test four — the Imperials begin their attack.

The first attack wave consists of TIE fighters and Interceptors attempting to disable the firing engine pod (that is, the one the PCs occupy). The ship is massively shielded, and the shield operator need make only an Easy *starship shields* roll to completely block the shots. Each failed *shield* roll results in minor damage to the engines, — all future difficulty numbers for *piloting* or *shield* rolls are at +2. The shields can be controlled from

the shield station, or from engineering or the captain's station (with the usual minus 1D).

After several rounds, the TIEs split their attention between the engine pod and the ship's cargo. The cargo section is protected by a different set of shields, which can be controlled as above. Note: if the same operator is controlling both sets of shields, he loses 1D from his *shield* roll for multiple actions. If any of the attacks against the cargo spheres get through, the cargo sphere's force shields begin to overload (see below).

The Final Test

Finally realizing their peril, the Imperials aboard the torpedo sphere begin serious jamming operations, totally overwhelming *Ice's* sensors. Then, several TIE fighters make kamikazi runs against the ship — targeting both the command capsule and the highly-volatile cargo spheres. Read:

Everything appears to be going well — it is obvious that you have caught the Imperials off-guard, and the TIE attacks have been ineffectual. With luck you will soon be plunging straight into the side of the torpedo sphere.

Just then, two more TIEs come in for attack runs. You'd think they would have learned by now that they cannot effectively penetrate the *Ice's* shielding. But there's something strange about this attack run. Why haven't they fired yet? It's as if — they're going to ram you! One's heading for the cargo spheres; one's heading right at the command capsule! A single shield won't be able to stop a kamikaze TIE fighter. The two shields together might be able to stop one, but that would leave either the spheres or the capsule undefended.

Suddenly, all of your instruments go black! The Imperials are jamming your sensors!

What do you do?

Well. Now things are beginning to get interesting, aren't they? Suddenly, the Rebels are flying blind, attempting to hit a target they cannot see, while being crashed into by starfighters they cannot avoid. This might be a good time for some Force points ...

First, the sensors. If the Rebels wish to break through the jamming, they are going to have to adjust their sensors' setting, while at the same time boosting their power. This takes two separate actions: a Moderate *Mechanical* roll from the sensors station, and a Moderate *starship repair* roll from engineering. If both rolls succeed, the sensors break through the jamming; otherwise, the ship is still blind.

At the same time, those operating the shields must attempt to block the incoming TIEs. To have any chance of success, the two shields must

both concentrate on blocking one ship — if they each try to block a ship, neither has any chance of success. If the sensors are operational, each *shield* attempt is Moderate difficulty; if the sensors are still jammed, the attempts are Difficult (the operators must rely on their memories of the TIEs' course).

If the TIE heading toward the cargo area gets through, a muffled *whuumppp!* runs through the *Ice*, and emergency lights and alarms begin flashing all over the bridge. The TIE has hit and breached one of the force balls, igniting the fuel inside. The fuel ball is beginning to glow bright red; it will blow in about two minutes and there's not a thing anyone can do about it.

If the TIE aiming at the capsule gets through, a louder clang rings throughout the ship and the lights flicker, but there is no other visible effect.

Finally, the pilot must attempt to compensate *Ice's* course for possible evasive maneuvers by the torpedo sphere. If *Ice's* sensors are operational, this is an Easy *starship piloting* roll; if not, this is a Difficult roll. If this roll is failed, the pilot may try again in subsequent rounds, but each failure incurs a +3 to the difficulty number.

Once the final course adjustment is made, it's time to get out. The ship is going to impact the torpedo sphere in under a minute, and there's nothing anybody can do about it. At this point, even if the Imperials manage to destroy *Ice*, its wreckage will seriously damage or destroy the sphere. The Rebels have succeeded — now all they have to do is try to get out alive.

There's Just One Small Problem

The Rebels head toward their shuttle. The trip is interesting: *Ice* is wracked by shudders as the TIEs, no longer impeded by the shields, score hits at will; lights flicker as the ship's automatic systems attempt to shunt power to the shields; bewildered Droids run everywhere ...

The trip takes five rounds. Every round, call for an Easy *Dexterity* roll from each of the heroes as the Rebels head for the docking bay — to avoid careening Droids, to slip under slamming security doors, to stay upright as the ship reels, and so forth. Keep track of the number of rounds in which a Rebel fails one of these rolls — it doesn't really matter, but you should keep the players very nervous. Continue with the next section.

The Docking Bay

The Rebels have reached the doors leading to the docking bay. If they did not successfully *shield* the TIE heading toward the capsule, read the following.

The ship rocks as a shot hits somewhere nearby. Panicked Droids whistle and beep

madly as they seek a place of shelter. *Ice* is falling apart around you. You don't think you'll make it. Finally, after what seems an eternity, you reach the door leading to the docking bay. Beyond the door is your ship — salvation if you can just reach it in time.

You run up to the door. It does not open. You hit the emergency override sequence. As the door opens, a massive wave of heat and flame shoots out to engulf you! Reacting quickly, you shut the door once more. As it closes, you see the flaming wreckage of a TIE fighter, lying directly atop the ruins of your shuttle.

You stare helplessly at each other. An instant later, the world explodes.

If the Rebels did block the TIE aimed at the capsule, then the one aimed at the cargo spheres got through. Read:

The ship rocks as a shot hits somewhere nearby. Panicked Droids whistle and beep madly as they seek a place of shelter. The ship is falling apart around you. You don't think you'll make it. Finally, you reach the door to the docking bay. Beyond the door is your shuttle — salvation if you can just reach it in time.

You run up to the door. It does not open. You hit the emergency override sequence. The door finally opens, and you rush inside to your ship. Disregarding the standard startup procedure, you fire up the engines. But before you can move, a loud crashing, twisting noise rocks the ship, sending your shuttle skittering across the bay, slamming into a side wall. Above the scream

of tearing metal, you can hear an alarm ringing through the bay. Accompanying the alarm is a recorded voice, saying: **"DANGER! CARGO HOLDEIGHT HAS COLLAPSED! DESTRUCTION IMMINENT! DANGER! DAN—"**

An instant later, the world explodes.

The End

The Rebels wake up. This should make the players very happy — if you have been doing your job right, they may very well believe that their characters are dead. Read:

Well, you're not dead — at least not yet, anyway. The ship is cold and dark, and the gravity has gone off; you're all wedged in a corner, along with several ruined Droids and some other unidentified wreckage.

You gingerly extricate yourselves from the pile up, and head for a viewport to see what's going on.

The engine pod is spinning and the world below you slips in and out of sight with alarming frequency — much too close for comfort.

You can't see what has become of the torpedo sphere — the viewport doesn't face in the proper direction. However, there is a warm glow coming from just beyond the edge of your vision, and a magnificent meteor shower is peppering the planet below with chunks of twisted metal. It looks like you did your job.

After much tinkering (and a few well-placed kicks), you manage to get a communications unit operational. The Rebel pilot you contact seems quite surprised to hear from you — they were convinced that no one had survived the collision. He promises to get you off what's left of the *Ice* before it impacts the atmosphere.

Several hours later, after a very tricky docking maneuver made by a foolhardy Rebel pilot, you are back at the base.

It's good to be alive.

Epilogue

The Rebels have saved the day, gaining Sector HQ the much-needed time to evacuate Fangol. Sector HQ quickly sets up on a new world, and the Rebels are heroes — again. Give each Rebel six to 12 skill points depending on their performances. Reward extra Force points if they personally manned *Black Ice* in episode six. See page 94 of the RPG book for more information on rewarding characters.

Then, when all is quiet, Major Lawra Mers approaches the heroes. She says, with a twinkle in her eye, "I need some volunteers ..."

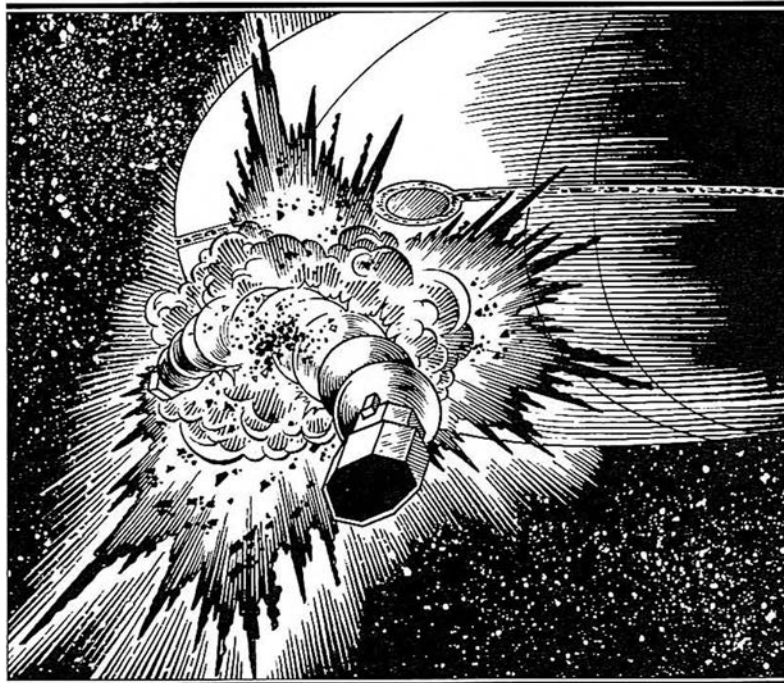

STAR WARS®

Black Ice

by Paul Murphy and Bill Slavicsek

Black Ice. 7,800 meters long — five times the length of an Imperial-class Star Destroyer. The pride of the Imperial Replenishment Fleet.

Black Ice. It carries nearly one billion tons of starship-grade fuel cells — more than a year's worth of power for an entire Imperial Main Battle Fleet.

Black Ice. If she remains in the Empire's hands, the Imperial Navy will cut a swath of destruction across the sector — and beyond.

Black Ice. The Empire will do everything in its power to protect her.

Black Ice. The Rebels must take her — or die in the attempt.

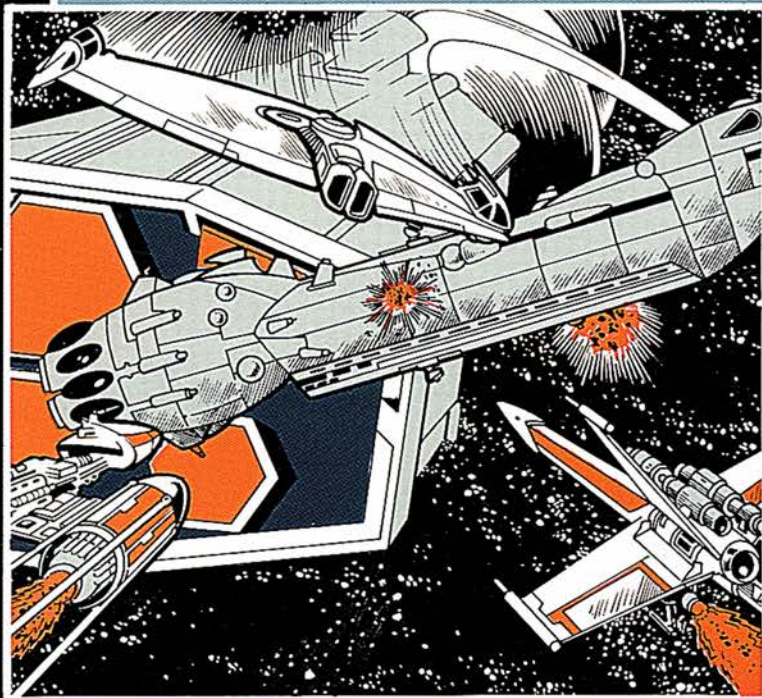

40-page booklet features:

- Maps of the Imperial cargo ship *Black Ice*.
- Detailed information about *Black Ice*, including deck plans, descriptions, and crew and Droid statistics.
- Pullout section full of more maps and non-player character templates.
- Action-packed script with parts for every player, plunging them directly into the action!

Also includes:

- *Star Warriors* mini-campaign, featuring multiple battles and ship repair and replacement rules.
- Counters for use with *Star Warriors*.
- Lots of gamemaster guidelines to help run this exciting adventure.

A complete adventure for *Star Wars: The Roleplaying Game*. For gamemaster and one or more players.

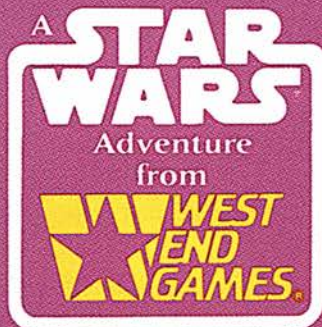

West End Games
RD 3 Box 2345
Honesdale, PA 18431

40030

For ages 12 and up.

©,™ & ©1990 Lucasfilm, Ltd. (LFL).
All Rights Reserved. Trademarks of
LFL used by West End Games under
authorization.

ISBN 0-87431-107-1

