

STAR WARS[®]

MOS EISLEY

Adventure Set

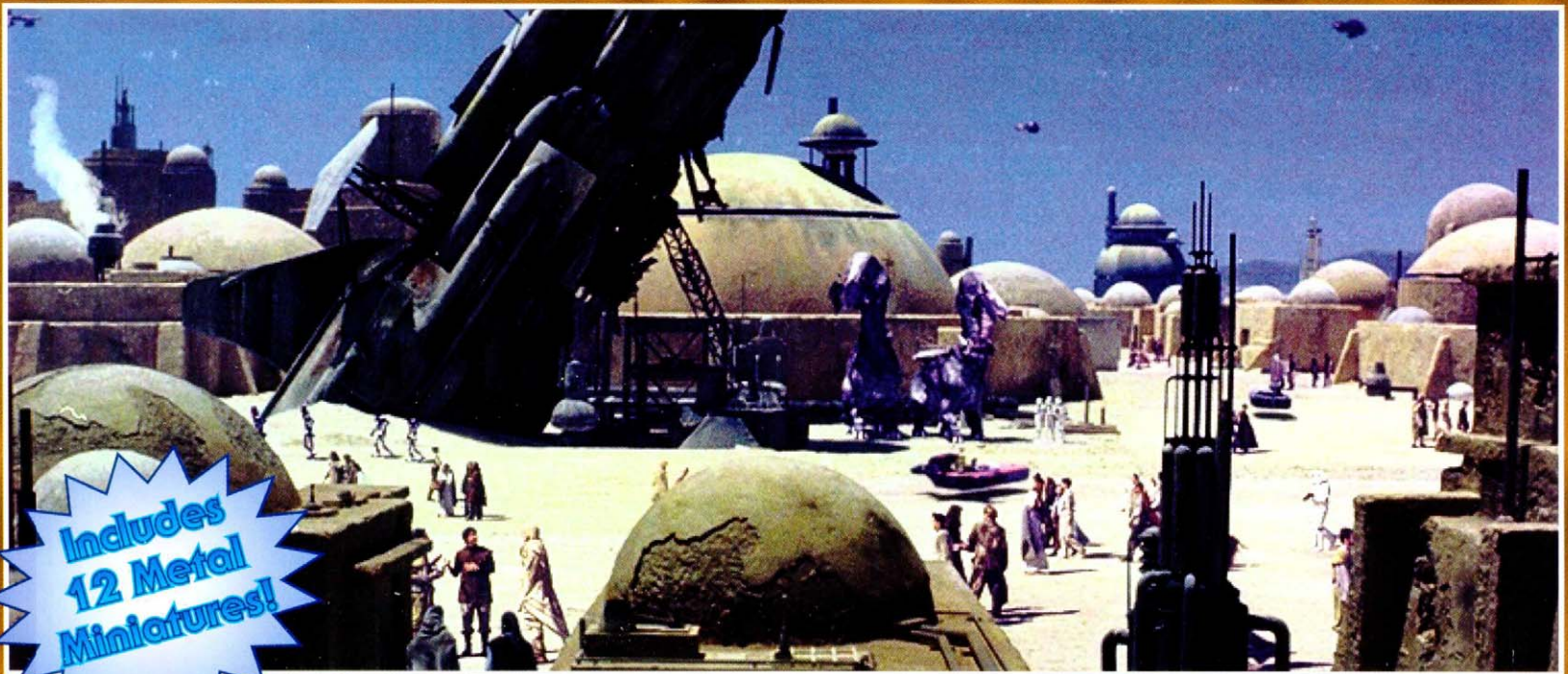

Includes
12 Metal
Miniatures!



STAR WARS®

MOS EISLEY Adventure Set

CONTENTS

Introduction	3
Vested Interest	10
There's Many A Slip Betwixt Cup and Lip	13
Harvest Day	18
The Passage from Perdition	21
A Line in the Sand	25
New Republic Adventure Hooks	31

Design: **Floyd Wesel** • Editing and Development: **Bill Smith** • Graphics: **Brian Schomburg** • Cover Art: **LFL** • Interior Art: **Christopher Trevas** • Additional Illustrations: **Paul Jaquays, Brian Schomburg**

Publisher: **Daniel Scott Palter** • Associate Publisher/Treasurer: **Denise Palter** • Associate Publisher: **Richard Hawran** • Editors: **Peter Schweighofer, Bill Smith, George Strayton, Paul Sudlow, Eric S. Trautmann** • Editorial Assistant: **Jen Seiden** • Graphic Artists: **Tim Bobko, Tom O'Neill, Brian Schomburg** • Sales Manager: **Jeff Kent** • Sales Assistant: **Carl Klinger** • Licensing Manager: **Ron Seiden** • Warehouse Manager: **Ed Hill** • Accounting: **Karen Bayly, Mary Galant, Wendy Lord** • Billing: **Sue Hartung**

Published by



RR 3 Box 2345
Honesdale PA 18431

40212

The speeder stops on a bluff overlooking the spaceport at Mos Eisley. It is a haphazard array of low, grey, concrete structures and semi-domes. A harsh gale blows across the stark canyon floor. Luke walks to the edge of the craggy bluff where Ben is standing.

"Mos Eisley Spaceport. You will never find a more wretched hive of scum and villainy. We must be cautious."

—Ben Kenobi





Introduction

It's a desert spaceport teeming with Jawas, strange aliens, and dangerous criminals. Welcome to Mos Eisley, a city of mystery, intrigue ... and adventure!

Every *Star Wars* gaming group shares the desire to *experience* this exotic location. This boxed set helps you do just that with adventures, characters and locations for your players to explore.

This box contains:

- This adventure book. The adventures in this booklet are designed two to six characters, preferably those with strong Rebel Alliance sympathies. Players may use smugglers or other independent characters, although you may have to adjust the motivation for each adventure to get the characters involved.

While most of these adventures are set shortly after the events of *Star Wars: A New Hope*, they can be customized to suit other eras, depending upon when your game campaign is set.

- *Galaxy Guide 7: Mos Eisley* provides a detailed look at some of the personalities and locations to be found in the spaceport city. While not exhaustive, this book provides plenty of starting points for adventures. *Galaxy Guide 7* is set a few months after the events of *Star Wars: A New Hope*.

- A 17" x 22" two-sided, color map featuring downtown Mos Eisley and the infamous cantina.

The cantina map is scaled roughly to match the scale of the metal miniatures: 1 inch represents two meters. By using the map, miniatures and counters, players and gamemasters can indicate exactly where their characters are at critical points during adventures.

The other side of the map shows part of Mos Eisley's crowded downtown spaceport, including the Mos Eisley Cantina, Docking Bay 94, Jabba the Hutt's Townhouse and a number of business and shops characters may need to visit. The rough scale is 1 inch represents 18 meters (one inch on this map is equivalent to nine inches in standard miniatures battles scale).

- A set of 12 *Star Wars* miniatures. Each miniature figure represents a specific individual from the *Star Wars* movies. These miniatures can be used for other characters, as well. For example, altering the paint scheme of the Greedo figure allows it to represent any Rodian.

Aside from painting and collecting, miniatures have practical value in both roleplaying and miniatures games, as they are used to show the actual locations of

characters during battles and other intense scenes. Use of miniatures allows players and the gamemaster to better visualize these situations. Miniatures also add a lot more fun to most game sessions, since players tend to get into the spirit of the game and move their figures around on the map.

The Miniatures

Below is a description of each miniature included in this set, with game stats as of the events shown in *Star Wars: A New Hope*. Each entry also includes hints for using the miniature in other roles.

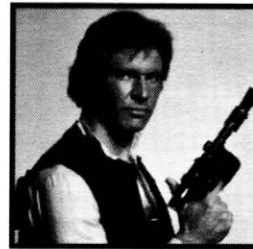

Han Solo

An infamous Corellian smuggler, Solo is the captain of the *Millennium Falcon*. He is known for his piloting skills and bravado. While the *Falcon* looks less than spaceworthy, it's one of the fastest ships in the space lanes. Unfortunately, Solo can't

outrun the trouble he inherited when he was forced to dump a shipment of Jabba the Hutt's spice. Jabba has since posted a huge bounty on Solo's head!

Painting Tips. Solo's vest is black; his pants are dark blue with a red Corellian Bloodstripe. His shirt is white.

■ Han Solo

Type: Smuggler

DEXTERITY 3D+1

Blaster 6D+2, blaster: heavy blaster pistol 9D+1, blaster: blaster rifle 5D+1, blaster artillery 6D+1, brawling parry 6D, dodge 8D, grenade 5D+1, melee combat 6D+1, melee parry 5D, missile weapons 4D, pick pocket 4D+1, running 3D+2, vehicle blasters 6D+1

KNOWLEDGE 2D

Alien species 6D, bureaucracy 5D, business 4D, business: smugglers 5D, cultures 4D, intimidation 5D+1, languages 5D, law enforcement 5D, planetary systems 7D, streetwise 7D, streetwise: Jabba the Hutt's organization 8D+2, survival 6D, value 5D, will-power 3D

MECHANICAL 3D+2

Astrogation 8D, beast riding 5D+2, capital ship gunnery 5D+1, capital ship piloting 7D, capital ship shields 4D+1, communications 4D, ground vehicle operation 4D+2, repulsorlift operation 7D, sensors 4D+2, space transports 6D+2, space transports: YT-1300 transports 10D, starfighter piloting 5D+1, starship gunnery 9D, starship shields 6D+2, swoop operation 6D+2

PERCEPTION 3D

Bargain 8D, command 6D, con 8D, forgery 5D, forgery: ship IDs 7D, gambling 8D, hide 7D+1, persuasion 5D, search 5D+2, sneak 4D+1

STRENGTH 3D

Brawling 7D, climbing/jumping 6D, lifting 5D+1, stamina 7D, swimming 4D+2

TECHNICAL 2D+2

Blaster repair 4D, computer programming/repair 7D, demolition 4D+2, droid programming 5D, droid repair 5D, ground vehicle repair 3D, repulsorlift repair 7D, security 7D, space transports repair 5D, space transports repair: YT-1300 transports 9D, starship weapon repair 4D

Force Points: 2

Character Points: 22

Move: 10

Equipment: Heavy blaster pistol (5D), comlink

Other Personas. This figure can be used for any civilian, including a smuggler, a thug, a mercenary or a security officer. Any color combinations are suitable.

Predne Balu. One of Mos Eisley's Assistant Security Officers, Balu can often be seen scouring the city streets. (Balu appears in several of the adventures in this booklet as well as the story "Nightlily" in the *Tales from the Mos Eisley Cantina* anthology.) Predne Balu has dark blue pants and vest, a gray shirt, and a tan holster and belts. He has black hair and eyes, with a gray beard.

**Chewbacca**

This towering Wookiee is the partner of Han Solo and first mate aboard the *Millennium Falcon*. While speculation runs rampant about how he and Solo teamed-up, no one disputes their loyalty to each other. Chewbacca is an out-

standing starship mechanic, but he's more widely known for his short temper and his considerable combat abilities. He carries a bowcaster.

Painting Tips. Chewbacca has dark brown fur and blue eyes. His bandolier and bowcaster are black; the bowcaster ammunition packs (on the bandolier) are silver.

■ Chewbacca

Type: Wookiee

DEXTERITY 2D+2

Blaster 5D+2, bowcaster 9D, brawling parry 7D, dodge 6D, grenade 5D, melee combat 8D, melee parry 8D, vehicle blasters 6D+1

KNOWLEDGE 2D

Alien species 6D+2, bureaucracy 4D, business 4D, cultures 3D+1, intimidation 8D+2, languages 5D+2, planetary systems 7D, streetwise 6D+1, survival 7D, value 7D+1

MECHANICAL 3D

Astrogation 8D, beast riding 4D, communications 3D+1, repulsorlift operation 7D, sensors 5D, space transports 6D+1, space transports: YT-1300 transports 8D, starship gunnery 7D, starship shields 6D

PERCEPTION 2D

Bargain 5D, command 4D+2, gambling 4D+1, hide 3D, search 3D, sneak 3D

STRENGTH 5D

Brawling 10D, climbing/jumping 7D, lifting 9D, stamina 10D, swimming 7D

TECHNICAL 3D+1

Blaster repair 5D+1, bowcaster repair 5D+2, computer programming/repair 8D, demolition 5D+2, droid programming 7D, droid repair 6D, first aid 5D, repulsorlift repair 6D, security 6D+1, space transports repair 6D+2, space transports repair: YT-1300 transports 10D+2

Special Abilities:

Berserker Rage: Chewbacca gains +2D *Strength* when brawling in berserker rage. See page 218 of *Star Wars, Revised and Expanded*.
Climbing Claws: +2D to climbing.

Force Points: 1

Character Points: 16

Move: 13

Equipment: Bowcaster (4D), ammo bandoleer, droid tool kit, starship tool kit, waist pouch

Other Personas. This figure can represent any Wookiee character. Wookiee fur can be tan, black, gray or even white, although brown is the most common color. Wookiees often have blue, black or gold eyes.

Chalmun. The charismatic Wookiee who owns the Mos Eisley Cantina has beige and gray fur.

**Greedo**

An ambitious but naive Rodian bounty hunter, Greedo has his sights on bringing in Han Solo. Greedo recently joined Jabba the Hutt's organization, but many of Mos Eisley's seasoned observers believe that his ego far out-

strips his abilities; the young hunter may not be around long enough to collect that precious bounty.

Painting Tips. Green skin, deep purple eyes, brown vest. Shirt and pants are green with yellow piping. Boots are green.

Greedo. *Dexterity 4D, blaster 6D, dodge 5D, grenade 6D, Knowledge 2D+2, intimidation 5D, languages 3D, streetwise 4D+2, Mechanical 2D+2, space transports 4D+2, starship gunnery 4D+2, Perception 3D, bargain 4D, investigation 4D, search 5D, Strength 3D+2, brawling 4D+2, Technical 2D, demolition 4D, space transports repair 3D.* Character Points: 2, Move: 10. Equipment: Blaster pistol (4D), grenades (5D).

Other Personas. The Greedo figure can represent any Rodian. You may change the shade of green for skin color and paint clothing as desired.

**Jawas**

Jawas are intelligent, rodent-like scavengers native to Tatooine. They are obsessed with collecting outmoded and abandoned hardware and selling the refurbished goods to moisture farmers and other locals. Roughly one meter tall,

Jawas wear coarse, homespun cloaks and hoods to shield them from the hostile rays of Tatooine's twin suns.

Painting Tips. Most Jawas have a simple brown cloak. Gloves and ionization blasters are black, while the ammo bandoliers may be black or tan. The "face" area should be painted black, with the exception of two brilliant orange eyes.

Typical Jawa. *Dexterity 2D, blaster 2D+2, dodge 3D,*

Knowledge 2D, streetwise 4D, survival: desert 4D+2, value 3D+1, Mechanical 3D, ground vehicle operation: sandcrawler 3D+1, Perception 1D, bargain 4D, con 3D+1, Strength 1D, climbing/jumping 2D+2, Technical 3D, computer programming/repair 4D, repulsorlift repair 4D+2. Move: 8. Equipment: Jawa ionization gun (+1D to blaster, 3D ionization damage which affects droids only), tool kit, brown robes.

Other Personas. One Jawa looks much like any other, so individual variations are minimal.

Het Nkik. Het appears to be an ordinary Jawa, but he believes in fighting those who would hurt his people, namely the Empire and Tatooine's dangerous Tusken Raiders.

Wrex. A Jawa "mercenary" working for Big Bunji. Wrex wears dark blue robes with gray highlighting.

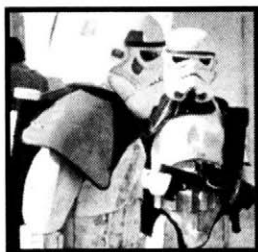

Imperial Sandtroopers

Imperial stormtroopers trained for desert survival, sandtroopers are equipped with special equipment to enable them to operate in this harsh environment. Sandtroopers often prefer to use

local beasts of burden instead of repulsorlift vehicles, which are often damaged by the harsh desert sands.

Painting Tips. Standard white uniform, with black body glove visible between armor plates. Shoulder pauldrons may be black, white or orange. Backpacks should be black.

Typical Sandtrooper. All stats 2D except: *blaster 4D, brawling parry 4D, dodge 4D, vehicle blasters 4D, survival 4D, beast riding 4D+1, search 3D+2, brawling 3D. Move: 10. Equipment: Heavy blast armor (+1D to Strength to resist damage, -1D to Dexterity and all related actions), blaster pistol (4D), heavy blaster rifle (6D), long-range comlink, food/water pack*

Other Personas. This figure could be painted with various colors to represent a rouge bounty hunter with stolen stormtrooper armor.



Labria

Labria is a Devaronian who's one of Mos Eisley's biggest drunks ... and one of its biggest squealers. While he's quite cunning, there's no such thing as secrecy to him; he's willing to sell information to anyone who has credits. He is known

as Jabba the Hutt's "least favorite spy" and often trades information with "Long Snoot" (Garindan) and other spies.

Painting Tips. Labria has light red-brown skin and brown horns. He wears red robes.

Labria. *Dexterity 2D, dodge 3D, Knowledge 3D, streetwise 4D, Mechanical 1D, astrogation 3D+1, Perception 2D+2, con 3D+2, hide 3D, investigation 4D+1, sneak 3D+2, Strength 2D+1, Technical 1D, computer programming/repair 3D. Character Points: 3. Move: 10. Equipment: Half-empty bottle of Jawa beer.*

Other Personas. Devaronians are fairly common aliens. Any other Devaronian character can be represented by simply changing the color of the clothing or altering skin tone.

Oxbel. This Devaronian, also a frequent customer in the Mos Eisley Cantina, claims to be Labria's brother. In truth, the two are no relation but they have used this scam for their own mutual benefit. Oxbel has very light brown skin and dresses in rustic, tan robes.



Garindan (Long Snoot)

Garindan is the premiere spy of Mos Eisley. It is often said that his "Long Snoot" sniffs out his targets for him. He works for the Imperial Prefect, a position currently held by Orun Depp. (It should be noted that Depp dies in the adventure

Tatooine Manhunt; by the time of *Galaxy Guide 7: Mos Eisley*, Mos Eisley's new ruler is Prefect Talmont.)

Jabba finds Garindan to be a particularly bothersome thorn in his side and he must spend a great deal of effort distracting the spy so that he can complete his business without Imperial interference. Not many people in Mos Eisley know this, but Garindan is a member of the Kubaz species.

Painting Tips. Garindan keeps himself well hidden under his black robes and gloves. He wears a gray shirt and gray pants. His snout is dark gray. He wears black goggles.

Garindan. *Dexterity 2D+2, blaster 3D+2, dodge 4D+2, Knowledge 3D, alien species 4D, languages 4D, streetwise 4D+2, Mechanical 2D+2, Perception 4D, con 5D, hide 6D, investigation 6D+1, search: tracking 5D, sneak 7D, Strength 2D+2, Technical 3D, computer programming/repair 3D+2, security 4D. Character Points: 3. Move: 9. Equipment: Comlink, blaster pistol (4D), hold-out blaster pistol (3D+1), 250 credits (for bribes).*

Other Personas. This figure could be used for any other Kubaz or a character wearing some sort of bizarre armor.



Lak Sivrak

This Shistavanen Wolfman is a recent arrival in Mos Eisley and not much is known about him. The notched blaster rifle he carries suggests he is a being not to be trifled with. He spends much of his time in the Cantina, but often keeps to himself; he has struck up a sort of friendship with the



Ithorian named Momaw Nadon. Unknown to most, Sivrak is a former scout who's now a Rebel spy; he, Nadon and Unut Poll (owner of Spaceport Speeders) work together to secretly advance the interests of the Rebel Alliance.

Painting Tips. Lak Sivrak has brown fur and black eyes. He wears a white shirt, brown pants and a worn red tunic.

Lak Sivrak. *Dexterity 2D+2, blaster 5D+2, dodge 4D+2, Knowledge 4D, alien species 6D, planetary systems 6D, survival 6D, Mechanical 3D, astrogation 5D, space transports 4D, starfighter piloting 4D, starship gunnery 5D+2, starship shields 4D+1, Perception 2D, hide 4D, search 5D, search: tracking 7D, sneak 4D, Strength 3D, climbing/jumping 4D, stamina 4D+1, Technical 3D+1, first aid 4D+1, space transports repair 4D+1, starfighter repair 4D+1.* Force Points: 3. Character Points: 9. Move: 11. Equipment: Blaster pistol (4D), blaster rifle (5D), vibroblade (STR+2D), survival gear.

Other Personas: Shistavanen Wolfmen are known for their scouting and piloting prowess, and may be encountered in many locations. Their fur tends toward black and brown, although other color variations — brownish-red, tan, gray or white — are possible. Many Shistavanen have black eyes, but others have red or gold eyes.

Tar and Kal Lup. This Shistavanen couple own Lup's General Store, which is in the same square as the Cantina. They both wear gray and yellow clothing.

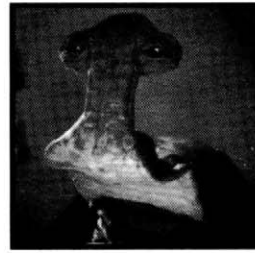

Momaw Nadon

Momaw Nadon is a peaceful Ithorian (or "Hammerhead") who now lives quietly in a small house on the outskirts of the city. His house contains an impressive greenhouse, with a multitude of plants from many worlds, including his

homeworld of Ithor. Nadon is secretly a Rebel operative.

Painting Tips. Momaw Nadon has brown skin and wears shabby red clothing. His powerstaff is brown with silver trim.

Momaw Nadon. *Dexterity 3D, dodge 4D, melee combat: powerstaff 4D, Knowledge 3D+2, agriculture 5D, bureaucracy: Tafanda Bay 7D, cultures 4D+2, ecology 6D, survival: jungle 5D, Mechanical 2D+1, repulsorlift operation 4D+1, Perception 3D+1, bargain 4D+1, Strength 3D, lifting 4D, Technical 2D+2, first aid 4D+2.* Force Points: 1, Character Points: 7, Move: 9. Agri-kit (+1D to survival), powerstaff (STR+2D).

Other Personas. Ithorians are a peaceful and gentle people known across the galaxy for their specially engineered plants. They are wandering traders and encountered on many worlds. Ithorians tend to dress in browns and greens, but some have a romantic flair, preferring flashier colors.

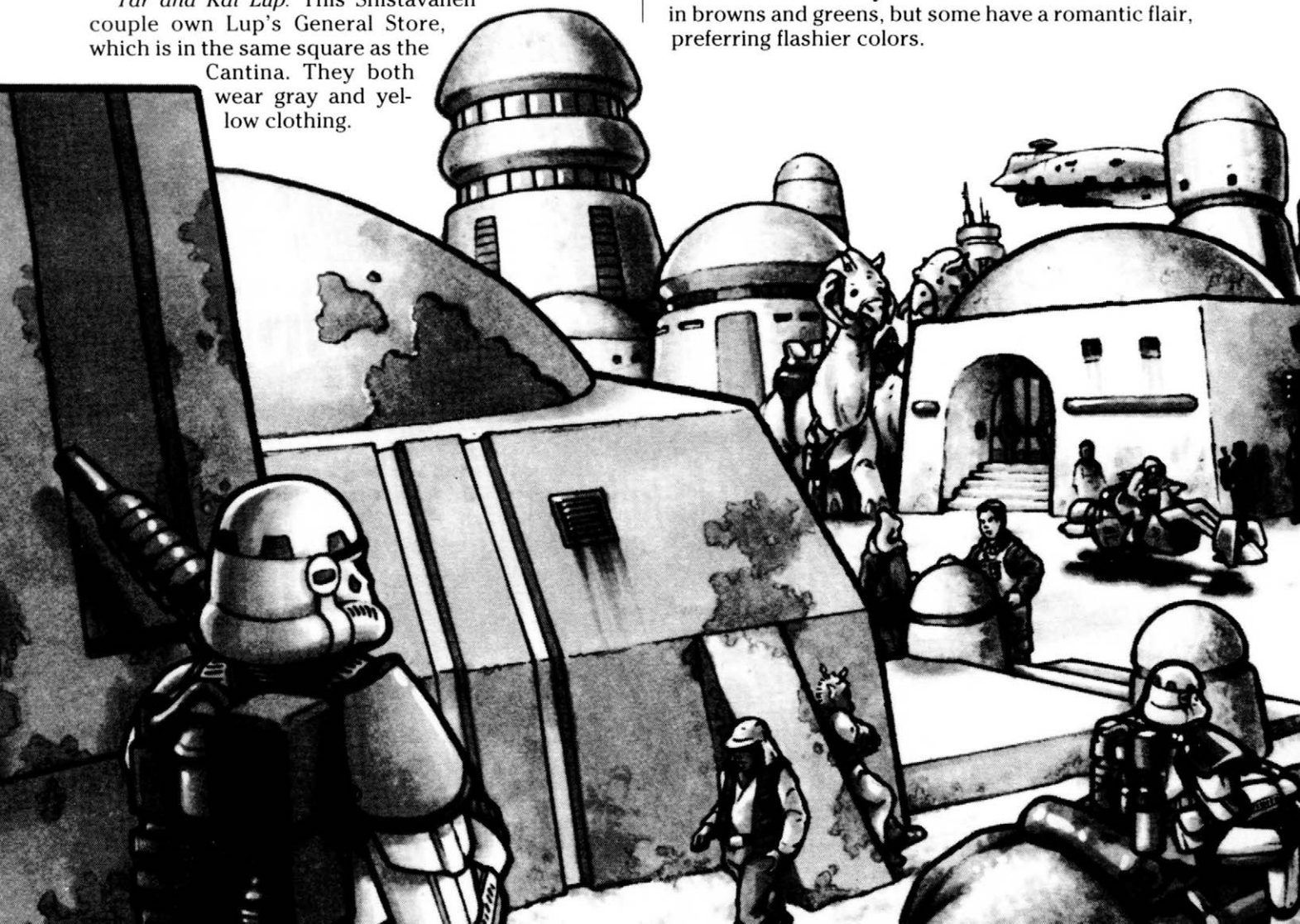



Kabe

Kabe is a young Chadra-Fan and she's become an excellent pick-pocket and petty thief through years of living on Mos Eisley's streets. Her guardian and protector is Muftak.

Painting Tips. Kabe has brown fur with a gray snout and ears. Her robes are red and she wears a white vest.

Kabe. *Dexterity 3D+2, dodge 5D+2, pick pocket 6D, Knowledge 2D+2, streetwise 4D+2, value 3D+2, Mechanical 3D, repulsorlift operation 4D, Perception 3D+2, con 4D, gambling 4D+1, hide 5D, sneak 5D+2, Strength 2D+1, Technical 2D+2, security 4D+2.* Move: 6. Security systems tool kit (+1D to security), knife (STR+1).

Other Personas. Kabe can represent any Chadra-Fan. These playful aliens are known for their curiosity and their tendency to pull apart machinery (putting the item back together is someone else's problem).



Muftak

Muftak is a hulking Talz who knows little about his people or his homeworld; for as long as he can remember, he has been an orphan living in the alleys of Mos Eisley. He tries to keep Kabe under control, but his young friend

seems to constantly drag him into trouble. Muftak is also friends with Momaw Nadon.

Painting Tips. Muftak's fur is gray. His eyes are black and the exposed skin on his hands and feet is brown.

Muftak. *Dexterity 2D+2, brawling parry 3D+2, Knowledge 2D+1, streetwise 4D+1, Mechanical 3D, beast riding 4D, Perception 2D+1, Strength 4D+1, brawling 6D, lifting 5D+1, Technical 3D.* Move: 9. Beat-up hold-out blaster (2D+1).

Other Personas. Talz are seldom encountered off their home world; those who can be found in spaceports are often slaves.



Feltipern Trevagg

Feltipern is a very corrupt official who works for the Mos Eisley city government. He delights in overcharging or conning the city's poorer citizens so he can claim their houses and resell them for a substantial fee. He is a Gotal.

Painting Tips. Feltipern wears a dull brown cloak. His skin is brown with gray highlights.

Feltipern Trevagg. *Dexterity 2D, dodge 3D+1, Knowledge 2D, intimidation 4D, law enforcement: Mos Eisley 6D, streetwise 4D+2, Mechanical 1D, Perception 2D+2, bargain 5D, con 4D+2, forgery 4D+2, investigation*





4D+2, search 4D+2, sneak 4D+1, Strength 2D+2, Technical 1D+2, computer programming/repair 3D. Energy sensitivity (+3D to search in open areas; +1D in crowded areas, but -1D in areas of intense radiation), mood detection (may get bonus or penalty with Perception skills due to ability to detect intentions of others), fast initiative (+1D to initiative roll against non-Gotals). Move: 10. Datapad, comlink, hold-out blaster (3D+1). (See *Galaxy Guide 4: Alien Races*, pages 46–48.)

Other Personas. This figure can be used for any Gotal in Mos Eisley. Gotals can be independent spacers or hired muscle, but they are well suited to be traders and con artists.

The Counters

Pages 30 and 32 of this booklet contain counters which may be photocopied, mounted on sturdy cardboard, colored and used in conjunction with the miniatures. While counters serve as an inexpensive way to fill out your miniatures armies, you should glue them to a washer or other weight to keep them stable during play.

A Line in the Sand

The counters for the scenario “A Line in the Sand” (on page 30) are as follows. Making three photocopies should provide plenty of soldiers if used with the miniatures and the counters on page 32.

Sandtroopers (10). There are three squads of sandtroopers in this battle.

Militia Members (3). Typical Mos Eisley Militia members, these troops wear tan clothing. The Mos Eisley symbol (on the chest) is light blue. Boots and blaster are black.

Women Militia Members (3). These counters represents ordinary citizens who have taken up arms to oust Prefect Talmont. Clothing may be of any color.

Militia Members with Vibro-Axes (3). These Mos Eisley Militia members also wear tan clothing with a light blue Mos Eisley symbol on the chest. The vibro-ax has a black handle with a silver or gray blade.

Swoop Gang Leader. This counter can be used for Swang, leader of the swoopers. Swang wears a red tunic and black pants. During the battle, any swooper gangers who abandon their vehicles can also be represented by this counter, or alternately, players could use a number of counters on page 32 to represent swoop gangers.

Prefect Talmont. Imperial Prefect Talmont dresses in solid black.

Diew Rejeff. This wealthy merchant dresses in tans and browns.

Swoops (3). The swoops should be gray and black, although swoop members may paint the cowlings and bodywork with any colors. They may also adorn their

swoops with personalized images, such as twin suns, krayt dragons or other symbols.

Counter Sheet

The counters on page 32 can be used in any number of adventures. They are as follows.

Top Row

Ponda Baba. Ponda Baba is a typical Aqualish thug. Ponda is currently working with Dr. Evazan and enjoys tormenting those who appear to be weaker than him.

Aqualish have green-brown skin. Ponda Baba wears an orange jacket, a blue shirt and pants, and black boots.

Dr. Evazan. A self-proclaimed “surgeon,” Dr. Evazan is an insane butcher who’s killed nearly two dozen patients in his gruesome experiments. He’s wanted in more than 30 systems; a dozen have standing execution orders. Evazan, who also goes by the aliases Dr. Cornelius and Roofoo, is hiding out since there’s a bounty on his head worth one million credits.

This counter can be used for any thug. Dr. Evazan has white skin and brown hair. He wears a white shirt, with brown vest and pants.

Myo the Abyssin. This violent Abyssin thug is known to frequent the Cantina. Myo is a mercenary with experience in desert survival; he’ll hire himself out as a desert guide, although he’s not to be trusted.

Myo has brown skin, with white fur. He has a single large, white eye with a black slit pupil. His shirt and pants are tan.

This counter can be used for any Abyssin.

Snaggletooth. “Snaggletooth” is a superb bounty hunter who specializes in capturing Thalassian slavers. He is a member of the Snivvian species. He has light brown-gray skin and black eyes, with brown and gray hair. He wears a red jumpsuit with dark blue trim.

Snivvians are a compulsive bunch, given to throwing themselves wholly into their tasks to better savor the experience. While most Snivvians are gentle and kind-hearted, those in violent professions — such as bounty hunters and smugglers — are quite dangerous.

Zogrov. A Snivvian dock worker, Zogrov wears dark green outfits with white highlights.

Takeel. This burnt-out Snivvian mercenary is often found in the Cantina looking for work. His mangy appearance hints at his down-trodden condition. He wears a ragged red shirt with black pants and boots.

Bom Vimdin. A dour and cynical mercenary, Bom Vimdin is a member of an alien species known as the Advossec (singular: Advosze). Vimdin is a smuggler with few scruples, caring little about the motives of those who hire him or what his cargo may be. He has extraordinary contacts in the galactic underworld; his presence in the Mos Eisley Cantina indicates he may now be working for Jabba the Hutt.



Vimdin has tan skin and black eyes. His horn is brown. His shirt is black with white sleeves; his vest is brown with silver buttons. He wears brown gloves and red-brown pants.

This counter can represent any Advozse. These aliens are known for their piloting skills and cynical natures. Several Advozsec smugglers frequently dock in Mos Eisley.

Kollan Xa. This operative represents the little-known Ccalras Corporation and spends much of his time seeking out influential individuals who might help him with trade negotiations. Xa favors bright red clothing.

Duro. Duros are aliens known for their piloting and mechanical skills. They can be encountered on almost any civilized world. Some of the characters the Duro counter can be used for include:

Baniss Keeg. Keeg hires himself out as a flight instructor. Considering the lucrative profits to be made in Jabba's smuggling syndicate, many of Tatooine's farm-boys seek out Keeg's expertise — although Keeg insists on full payment in advance since many of the new pilots fall victim to Imperial patrols and the ire of Jabba the Hutt. Baniss Keeg has blue-gray skin and red eyes. He wears brown coveralls.

Kov Du Derra. Kov is a fierce bodyguard and has the scars to prove it. He works for Kollan Xa. He wears white overalls with black boots and highlights.

Chachi and Ohwun De Maal. This Duros couple own and operate Docking Bays 27, 43, 67, 71, 86 and 94. Chachi and her husband are forced to pay protection money to Jabba the Hutt. They wear matching green and blue workers' suits.

Mos Eisley Militia, Mos Eisley Militia with Vibro-ax. See the description for these counters under "A Line in the Sand."

Mace Windu. Mace Windu is a hyperactive Squib who is co-owner of Jawa Traders, a droid lot in downtown Mos Eisley. He has gray fur. This counter can be used to represent any Squib.

Beeyon Nace. Beeyon Nace is a Spaceport Control worker who spends most of his free time in the Mos Eisley Cantina. He wears a black cloak with a gray shirt and brown pants.

Jawa. A typical Jawa, with brown robes and orange eyes.

Tusken Raider. A typical Tusken Raider figure.

Whiphid. Whiphids are massive aliens known for their short tempers. They greatly prize the art of hunting. Whiphids have yellow-white or golden fur.

Arcona. Arcona generally have gray to mahogany colored skin. Arcona have glittering, sparkling green eyes; those with gold eyes are addicted to salt.

Mos Eisley has at least two well-known Arcona:

Unut Poll owns Spaceport Speeders, while Hem Dazon is a salt-addicted scout who's been spotted in the Cantina.

Bottom Row

Arakyd BT-16 Security Droid. The BT-16 security droid has six legs (for greater mobility) and a powerful repeating blaster. The droid is black with silver trim.

Landspeeder. A typical landspeeder. It may be almost any color.

Swoop. See the description for this counters under "A Line in the Sand."

Gotal. Gotal tend to have gray and brown skin.

Gran Thug. Gran have pale skin with black eyes. Those Gran working as thugs tend to dress in black and other dark colors.

Rodian Thug. Rodians are found throughout Mos Eisley; many of them are on Jabba the Hutt's payroll. They have green skin and black eyes.

Kayven Whistler. Jabba the Hutt keeps several of these creatures as pets in his townhouse. They are quite useful for disposing of meddlesome competitors. They are black and brown with green eyes.

Twilek Woman. In the adventure "Vested Interest," a Twilek woman poses as a slave to lure Beeyon Nace into working for Jabba the Hutt. Twileks may have pale brown, pink or green skin.

Assembling Your Counters

To assemble your counters, cut along the solid lines and fold along the dotted lines (see Figure 1 below). To make the stand, interlock the tabs on their bases (see Figure 2).

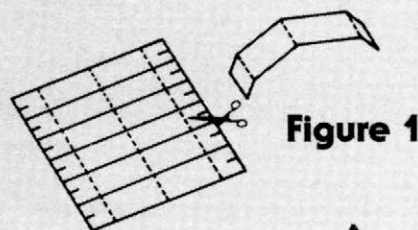

Figure 1

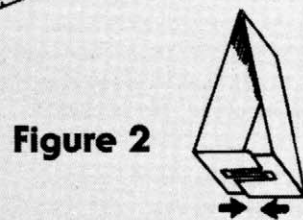

Figure 2



Vested Interest

Zogrov, a Snivvian dock worker and an associate of the characters, approaches them with a request for help. His friend, Beeyon Nace, has been particularly sour of mood. Zogrov found out that Nace is being forced to spy for Ccalras Corporation, a company with a reputation for violence and ruthlessness.

Zogrov. All stats 2D except: *blaster 4D+1, dodge 5D, Knowledge 3D+1, language 4D, business 3D, streetwise 4D, Mechanical 2D+1, repulsorlift operation 4D, space transports 3D, starship gunnery 3D, Perception 4D, bargain 6D, investigation 6D, search 6D, Strength 3D, brawling 3D, Technical 3D, first aid 4D.* Special Abilities: adaptive skin (Snivvians can survive in temperature extremes of minus 30 degrees standard, to temperatures up to 45 degrees standard without protective gear, +1D against physical damage). Character Points: 4. Move: 11. Equipment: Comlink, blaster pistol (4D), 250 credits.

Knowing that his friend is scheduled to meet with Ccalras this coming evening — it's now midafternoon — Zogrov begs the characters to investigate the situation and see if they can help Nace. Perhaps they can find what Ccalras is holding over him and somehow stop him from signing with the company. Zogrov knows only that Ccalras's representative is Kollan Xa.

It's for Your Own Good

Zogrov suggests to the characters that they should "kidnap" Nace to protect him from Ccalras. He's currently on duty at the Mos Eisley Spaceport Control Tower (see page 64 of *Galaxy Guide 7*) — it would be tricky to kidnap him with so many starport security officers in the building — but the characters could also confront him after work. He normally heads straight for the Cantina after finishing a work shift. When the characters have Nace, they are to go to the Cantina to get Zogrov.

Beeyon Nace. All stats 2D except: *Dexterity 3D+1, blaster 4D+2, dodge 3D+2, Knowledge 3D, bureaucracy 5D+2, languages 4D, streetwise 3D+2, Mechanical 3D, astrogation 4D, repulsorlift operation 3D, Perception 3D+1, bargain 3D, gambling 4D+1, Technical 3D, computer programming/repair 5D.* Character Points: 4. Move: 10.

Starport Security Officers. All stats 2D except: *blaster 3D, brawling parry 3D, dodge 4D, vehicle blasters 4D, intimidation 3D, survival 3D, beast riding 3D+1, command 3D, search 3D+2, brawling 3D.* Move: 10. Equipment: Blast vest (+1D physical, +1 energy), blaster pistol (4D), comlink, IDs.

When the characters confront Nace though, he is anything but helpful. He screams for help and tries to get away from them. Once they calm him down, he becomes sullen and refuses to talk, saying only, "There's no way out of this mess. I'm going to do what I have to do!"

Searching Nace's person reveals a datachip; if the characters don't search him, it slides out of his pocket in front of them. When the chip is read in a datapad, the characters find the name Kollan Xa, with a note that he has a room at the Lucky Despot Hotel. There is a prerecorded message which shows a dangerous-looking Advoszec; Nace admits this is Kollan Xa. In the message, the alien says, "Nace, you be at the Lucky Despot's lounge by nightfall or else. No tricks, no trouble, and she lives. If you try to double-cross me, I'll let them sell her to the slavers."

Zogrov's Aid

When the characters contact Zogrov after capturing Nace, the Snivvian offers to hold Nace in his small apartment, which is two blocks from the Mos Eisley Cantina. Nace calms down slightly when Zogrov arrives and appears to be somewhat cooperative. Zogrov sends the characters to the Lucky Despot with orders to spy on Kollan Xa.

The Lucky Despot Hotel

At the Lucky Despot, the characters spot the Advoszec talking to a Duro. They overhear that the Duro's name is Kov Du Derra. Xa tells him, "Go to the guest house and make sure Nace's lady love is comfortable. We need to keep her under wraps until our business is done."

Kollan Xa. All stats 2D except: *dodge 5D, melee combat 3D+2, melee parry 3D+1, Knowledge 3D, alien species 4D, bureaucracy 4D, law enforcement 4D, streetwise 5D, value 4D, Mechanical 3D, repulsorlift operation 4D, Perception 3D+2, bargain 7D, con 5D+2, gambling 4D+1, hide 4D, investigation 5D+2, Strength 3D, brawling 3D+1, Technical 2D+2, computer programming/repair 3D, demolitions 3D+1, repulsorlift repair 3D+2, security 3D+1.* Character Points: 2. Move: 9. Equipment: Hold-out blaster (3D+2), 500 credits, comlink.

Kov Du Derra. *Dexterity 4D, blaster 6D, dodge 5D, Knowledge 2D+2, intimidation 5D, languages 3D, streetwise 4D+2, Mechanical 3D+1, space transports*



4D+2, starship gunnery 4D+2, Perception 3D, command 4D, investigation 4D, search 5D, Strength 3D, brawling 4D+2, Technical 2D, demolition 4D, space transports repair 3D. Character Points: 3. Move: 10. Equipment: Blaster pistol (4D), comlink.

Following the Duro

The characters quickly discover that following Kov Du Derra through the crowded and twisted streets of Mos Eisley is anything but easy. During their journey, the characters are spotted by some thugs they annoyed during an earlier misadventure. The thugs — one for every character — pursue the characters and attack; Du Derra slips away.

Thugs. All stats 2D except: *blaster 3D, dodge 2D+1, melee combat 2D+1, melee parry 2D+1, streetwise 3D+2, brawling 4D.* Move: 10. Equipment: Comlink, vibroblade (STR+1D), blaster pistol (4D).

Staging Tips. This chase and battle — and the continuing pursuit of Du Derra — can involve a number of incidental encounters. For example, the characters may stumble upon a droid who's looking for its master (perhaps one of the characters bears a passing resemblance to this person), a pick-pocket who tries to rip off one of the characters, or a traffic jam caused by a minor landspeeder accident.

During the chase, a pair of Jawas on a ronto cross

between the two groups, giving the characters a chance to get away from the thugs.

Ronto. *Dexterity 2D, running 3D, Perception 3D, Strength 5D, stamina 6D.* Special abilities: Heat endurance (rontos are extremely adaptable to desert conditions), sense of smell (rontos have keen senses of smell and get +1D to any *Perception* roll involving smell), skittish (rontos are easily upset by any machines that move quickly; add +3D to their orneriness when around fast-moving vehicles). Move: 10. Orneriness: 1D

During the battle, several of Mos Eisley's militia soldiers arrive. Assistant Security Officer Predne Balu questions the characters while the other militia troops round up the thugs. If the characters claim that they're just victims, Balu lets them go: witnesses already reported that the characters were attacked without provocation.

Mos Eisley Militia Officer. All stats are 2D except: *blaster 3D+2, dodge 4D, melee combat 3D+1, law enforcement 3D+2, streetwise 3D, con 2D+2, command 2D, brawling 3D.* Move: 10. Blaster pistol (4D, normally set on stun), comlink, three sets of binders, stun baton (Moderate difficulty, STR+1D stun), blast vest (+1D physical, +1 energy).

Staging Tips. A positive encounter with Balu and the militia troops gives the characters a chance to

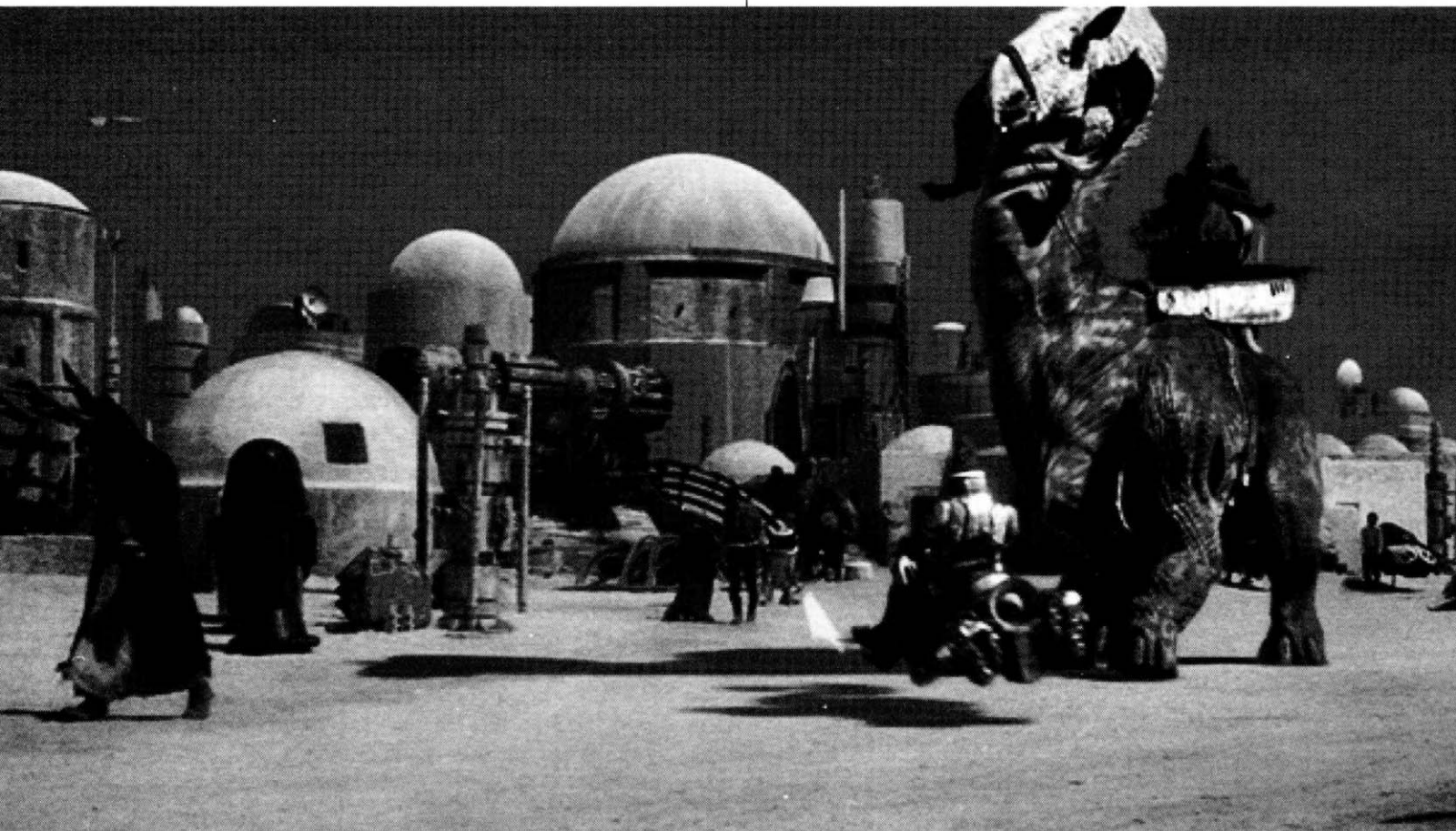



establish a contact that leads into the adventure “Harvest Day.”

Picking Up the Trail

After the characters evade their pursuers, a Dim-U priest approaches the characters and asks them if they were “following someone.” He knows they were, and for a small donation of 10 credits to the “Adopt A Bantha Foundation,” he will gladly point them in the right direction!

After adopting a bantha (they get holos and monthly updates), the Dim-U priest gladly points them in the right direction. They quickly pick up the trail of the Duro.

A Helpless Captive

They follow the Duro to a house on the edge of the city. He goes in for a few minutes, then leaves, heading back into the center of the city.

If the characters observe the house’s occupants, they see a slim and very attractive Twi’lek woman and a hovering security droid (as well as Du Derra if he’s still there).

If the characters enter the house, the droid tries to stop them, while the woman ducks for cover.

Security Droid. All stats are 2D except: *blaster 4D, dodge 4D, Strength 3D*. Armor plate (+1D), blaster pistol (4D). Move: 12.

The woman acts very sweet and innocent, but volunteers as little information as possible. Eventually she offers that her name is Eila. If the characters mention Nace, she claims that she’s Nace’s sweetheart. She says that she’s going to be sold into slavery and Nace is joining Ccalras to try to save her. She begs the characters to help her!

Eila. All stats 2D except: *streetwise 5D, bargain 4D+2, con 6D, search 4D+2, sneak 5D+1*. Move: 10. Hold-out blaster (hidden, 3D+2).

Staging Tips. Play Eila as charming and seemingly naive, but she’s not that good an actress. At times, her true personality — snide, manipulative and cruel — slips through, although she normally catches herself and corrects her behavior.

The Reunion

Returning with Eila brings Nace out of his depression. Nace seems quite content.

Zogrov thinks he can help — he digs out a pair of Dim-U priest robes, and explains that he’s on good terms with Abbot Drayk, who runs the Dim-U Monastery. He says that he can arrange for the couple to be

hidden at the Monastery. He hurries the group along, asking the characters to scout ahead and make sure the path is clear for Nace and Eila.

As the characters sneak through the city, Zogrov keeps contact with his comlink. Eventually, the comlink broadcasts the sounds of a scuffle and a couple of blaster shots. When the characters make their way back to Zogrov, they find Eila is holding a hold-out blaster on both Nace and Zogrov. Kollan Xa, Du Derra and several Klatooinan thugs have joined the woman.

Just as the characters come upon the scene, Eila says that she wants double the money she was promised for this con. Now that Nace realizes that he’s been made out to be a fool, he turns into a blithering idiot, continually muttering about how unfair his life is.

Kollan Xa’s Thugs. All stats 2D except: *blaster 2D+1, brawling parry 3D+2, dodge 2D+2, melee combat 3D, melee parry 2D+2, intimidation 3D+2, streetwise 3D+2, brawling 4D, lifting 3D, stamina 2D+2*. Move: 10. Equipment: Comlink, vibroblade (STR+1D), blast vest (+1D physical, +1 energy), blaster pistol (4D).

If the characters act quickly, they should be able to duck out of sight before Xa and his thugs spot them. If they linger, Xa orders his men to attack while he, Eila and Du Derra try to drag Nace and Zogrov away.

This scene can lead to an exciting chase, but the characters should eventually come up with a plan to drive off Kollan Xa and rescue Nace and Zogrov. When the dust settles, Zogrov insists that they all head to the Dim-U Monastery for shelter. Upon arrival there, Zogrov and Abbot Drayk greet each other as old friends. Nace explains to Drayk that Ccalras Corporation is blackmailing him: Xa and Eila used the ruse of a romance. Nace knows Xa will now just threaten him unless he cooperates: Ccalras wants him to report on security and customs patrols.

Drayk smiles, explaining that Ccalras is a front company for Jabba the Hutt. Because of several recent incidents, particularly that one with Solo, Mos Eisley Customs has been much more strict in inspections. Jabba is looking for ways to get his cargoes in and out of Mos Eisley without any hassle.

Jabba can be quite persistent, but Drayk can offer some sort of protection: the Dim-U Monastery hides a computer slicing and forging operation. If Nace is willing to provide the occasional false transponder code, Drayk promises that he can use his contacts in the city to keep Jabba’s minions quite distracted ... distracted enough that they’ll forget all about Nace!

There's Many a Slip Betwixt Cup and Lip

The characters are contacted by Labria, who has a valuable cargo he's willing to part with. If they bring plenty of credits to the Mos Eisley Cantina, perhaps a deal can be arranged.

Upon meeting Labria at the Cantina, he explains that he knows how to get a cargo of espionage matrixes for use in protocol and servant droids. These valuable droid parts could be very helpful to any number of beings, including Jabba the Hutt or perhaps the Rebellion. Labria wants 10,000 credits for the cargo of 50 matrixes; any character making a Moderate *value* or Difficult *streetwise* or *droid programming* roll realizes the cargo is worth 50,000 credits on the black market.

With prodding, Labria reveals that this cargo belonged to a careless spacer who was arrested by Mos Eisley Customs for smuggling. The spacer is now sitting in the Mos Eisley Police Station. The police don't have enough officers to guard the cargo, so it's still in a docking bay behind locked doors, undelivered and unclaimed. If the cargo is "taken care of" before the smuggler is released, there are plenty of profits to be made.

While Labria is wrapping up his explanation, he is interrupted by a menacing-looking Rodian, who is accompanied by a Jawa in blue robes and a young Chadra-Fan. The Rodian snarls at Labria, pulling him away from the table. The Rodian tersely tells the characters (in Basic) that Labria has a very important meeting *now*.

The trio forces Labria out the back door. If the characters try to protect Labria, the Jawa and the Chadra-Fan distract them by kicking them in the shins and trying to scuttle away and hide in the crowd. Meanwhile, the Rodian continues to drag Labria, who is screaming for help. No one in the Cantina acts to protect the Devaronian.

Rait the Chadra-Fan. All stats 2D except: *blaster* 2D+1, *dodge* 3D, *pick pocket* 4D, *languages* 3D+2, *streetwise* 3D, *con* 3D+1, *search* 3D+2, *Strength* 1D+2, *climbing/jumping* 3D. Move: 8. Equipment: Stun pistol

(4D stun), 5 credits, miscellaneous useless trinkets.

Rait is a nervous, chattering Chadra-Fan. He acts as a spy and look-out for Voushon. While nervous around strangers, once he gets used to someone he becomes quite curious, incessantly poking and prodding his new friends. While he doesn't speak Basic, Rait understands the language.

Wrex the Jawa. All stats 2D except: *blaster* 2D+2, *dodge* 3D, *streetwise* 4D, *survival: desert* 4D+2, *value* 3D+1, *Mechanical* 3D, *ground vehicle operation: sandcrawler* 3D+1, *Perception* 1D, *bargain* 4D, *con* 3D+1, *Strength* 1D, *climbing/jumping* 2D+2, *Technical* 3D, *computer programming/repair* 4D, *repulsorlift repair* 4D+2. Move: 8. Equipment: Jawa ionization gun (+1D to *blaster* skill, 3D ionization damage affects droids only), tool kit, worn blue robes, bandoleers with pouches.

Wrex is a typical Jawa, although he prefers blue robes to the traditional brown. Wrex acts as a liaison between Big Bunji and the various Jawa tribes that trade in Mos Eisley. Wrex is also a good spy since few people bother to notice the tiny Jawa lurking in the background.

Voushon the Rodian. *Dexterity* 4D, *dodge* 5D, *melee combat* 6D, *melee parry* 5D, *Knowledge* 2D, *intimidation* 4D, *survival: desert* 5D, *streetwise* 4D, *Mechanical* 3D, *beast riding* 5D, *Perception* 3D, *search* 5D, *Strength* 4D, *brawling* 5D+1, *climbing/jumping* 5D, *lifting* 5D, *stamina* 6D, *Technical* 1D+2, *first aid* 3D. Character Points: 5. Move 11. Equipment: Blaster pistol (4D), vibroblade (STR+1D).

Voushon has worked for Big Bunji for a couple of years and is now trying to mastermind a rescue mission. He speaks Basic fluently, although his voice has a nasal, squeaky tone. While Voushon tries to come across as a stereotypical heartless thug, he's actually a lot more moral than he lets on. Voushon likes smuggling because no one gets hurt. The Rodian plays tough, but is extremely reluctant to use physical vio-



lence — although he's enjoying terrifying Labria since the Devaronian spy has been a thorn in his side for a long time.

When the characters catch up with the group, the Rodian and his two companions are threatening Labria. Labria is trying to talk his way out of trouble:

"It's not my fault. Big Bunji and I have done business for years. I wouldn't want to see him hauled off to an Imperial prison facility. I didn't do it ... someone else must've tipped the Customs crews off. Maybe it was Garindan? I didn't do it — I swear!"

If Labria sees the characters, he begs for help. He makes sure not to mention the droid matrixes. If the characters rescue Labria, he tells them that those "dangerous thugs" work for Big Bunji, the smuggler who got arrested for having the droid matrixes. He says they blame him for Bunji's arrest, but he had nothing to do with it; someone else must have told the Customs department about the droid matrixes!

Labria then slyly explains that Bunji's impounded ship is in Docking Bay 86: if the characters hurry, they should be able to steal the cargo before Bunji's associates get back to the bay. Cut to "Docking Bay 86."

If the characters mention the droid matrixes in front of Bunji's associates, Voushon the Rodian gets quite angry but lets Labria go. He then recruits the characters; cut to "The Deal."

Docking Bay 86

If the characters try to break into Docking Bay 86, they must first make a Moderate *security* roll to get through the locked doors without setting off the alarm. Failing the roll by three or more points means the characters activate the alarm system: Mos Eisley Spaceport Security guards arrive 10 minutes later to investigate.

Inside the bay, the characters see a nondescript Corellian YT-1300 freighter. No one is inside the bay.

The freighter also has a lock system — the characters must make a Difficult *security* roll to pry open the locks. Failing the roll simply means that the ship remains locked; there is no alarm.

Once aboard the ship, a thorough search reveals that there is no cargo aboard. While the characters are conducting their search, Voushon, Wrex, and Rait return to the docking bay. They soon confront the characters, but rather than fight, they offer to make a deal. When the characters ask about the cargo, Voushon laughs. "Labria's sources were wrong again. But if we work together, we can all get rich ..."

Cut to "The Deal."

The Deal

Voushon is trying to recruit the characters to help him. He explains the situation:

"My boss is Big Bunji, one of the big smuggling brokers here in Mos Eisley. Although he's quite wealthy, he still likes to roll up his sleeves and go out on a run now and again just to keep the reflexes

sharp. This time, though, he got himself into a lot of trouble.

"He was hauling a cargo of espionage droid matrixes. Big credits in the right place, and Mos Eisley's the right place. It was too tempting for Bunji to pass up.

"Too bad there are some jealous types around here. Someone told Customs what was going on and Bunji got himself arrested.

"The Customs officials arrested him on minor stuff ... paperwork out of order, that sort of thing ... because Bunji hid the cargo. Unfortunately, Bunji's been in trouble on a bunch of worlds and most of them want his skin. The Imperials are supposed to arrive soon and take him off-planet to stand trial.

"Then there's the cargo. We don't know where it is, the Customs goons don't know where it is, Labria sure doesn't know where it is ... even the mighty Jabba would have a tough time tracking this cargo down. And it's worth a lot.

"Here's the deal. You help us rescue Bunji, we'll give you 10 of those matrixes on the condition you sell them off world. They're worth 10,000 to the right people."

Voushon isn't willing to budge: he's offering a fortune. And, as he's quick to point out, how hard can it be to bust someone out of Mos Eisley's police station?

Once the characters accept, Voushon sends the characters and Wrex on several errands, while he and Rait go to study the Mos Eisley Police Station. The characters must do the following:

- Find out when the Imperial prison shuttle is arriving. If the characters have no idea where to begin, Voushon suggests they contact Abbot Drayk at the Dim-U Monastery or they should find someone at the Spaceport Control Tower. Cut to "The Prison Shuttle."
- Arrange for a get-away speeder. Wrex says he knows just the place. Cut to "A Not-So-Quick Get-Away."
- Find an escape ship. If the characters don't have any contacts in the smuggler community, Voushon suggests they seek out Bom Vimdin, an Advoszec smuggler who frequents the Mos Eisley Cantina. Cut to "Transportation Off This Rock."

Spies in the Shadows

While the characters are completing these errands, they have another encounter with Labria. They spot him while he's obviously trailing them; if confronted, he sincerely apologizes for the earlier misunderstanding. He explains that he was working with incomplete information before, but he'd love to help the characters earn a fortune. He proposes joining forces, offering to split the take. He even says that he can get additional guards to overpower Bunji and his companions, so he and the characters can have the whole cargo to themselves.

However, this is all a ruse by Labria. He truly ex-

pects the characters to chase him away, but his main objective is to distract the characters for a few minutes. Lurking in the background is Garindan ("Long Snoot"), who's trying to discover where the cargo is. Garindan has hired several people to "jostle" the characters as they walk by; one of these citizens has a micro-comlink, which is supposed to be inconspicuously slapped on a character's shirt. Garindan plans to listen in on the comlink and follow its homing beacon to learn the characters' plans.

The citizen attaches the comlink; unless the character makes a point of thoroughly searching his person for the comlink, a Very Difficult *hide* roll is needed to spot the comlink, which is barely a centimeter across.

The Prison Shuttle

To learn when the prison shuttle is going to show up, the characters can go to Abbot Drayk at the Dim-U Monastery or Beeyon Nace at the Spaceport Control Tower. If things went well in "Vested Interest," both should be willing to help out for a modest fee.

Wrex — via a droid on hand that interprets for him — promises 1,000 credits. Nace accepts this fee. Drayk demands no less than 5,000; Wrex eventually agrees.

Nace simply has to look at the incoming ship schedule. In Drayk's case, once the characters have left, he calls Nace to get this information. In both cases, the characters are assured that they'll be called via comlink once the information is found.

A Not-So-Quick Get-Away

For a get-away vehicle, Wrex drags the characters to Jawa Traders. He says that he's on good terms with Aguilae, the Jawa co-owner, and they should be able to get a great deal.

Upon entering the droid lot, they are greeted by Mace Windu, a Squib and the lot's other co-owner. Mace says that Aguilae isn't in today, but he promises to make a "good, good, best" deal. After Wrex jabbars for a few minutes, Mace admits that he does have a landspeeder out back, but it's "valuable much. Need plenty of good stuff to let it go."

While the negotiations initially involve only Mace and Wrex, Mace quickly drags the characters into the middle of the deal by demanding some of their possessions.

Staging Tip. This scene should be a humorous and incredibly intricate negotiation scene. As Mace makes the deal more complex, the characters should start to feel that "no reward is worth this."

While Mace and Wrex prattle on, a trio of mean-looking "customers" come onto the lot. They interrupt Mace and soon begin bullying him; the characters overhear that they are actually some of Jabba's thugs and they're looking for the protection money they're owed. While Mace tries to stand up to them, the thugs soon start knocking over the droids and threatening him.

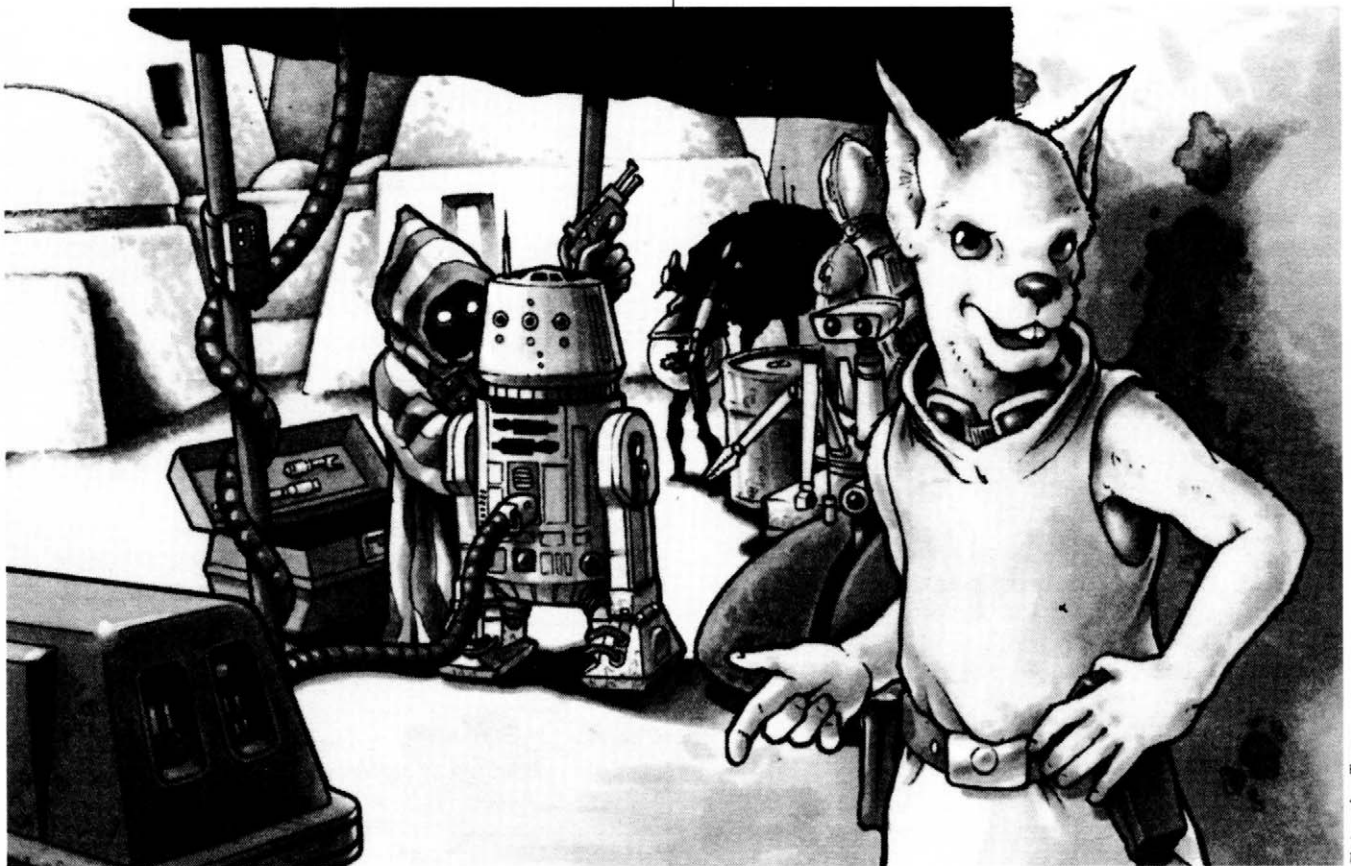

Christopher Trevas



Wrex tries to get out of the way, but trips over one of the thugs. In some way or another, the characters should become involved in this confrontation — if nothing else, the thugs start hassling them as well.

The thugs flee once the characters stand up to them. In gratitude, Mace promises to loan Wrex and the characters the landspeeder out back, but they have to promise to bring it back in good shape.

The landspeeder seats eight beings and appears to be in good shape; it has a brilliant blue paint scheme and silver trim. However, once the repulsorlift drive is started up, smoke begins belching from the back. (Mace assures the characters that there's nothing wrong. "The smoke will stop right away ... faster than that, even.") Eventually, the smoke stops, and while the speeder does run reliably, it's hard to get over the smell of burning circuitry that fills the passenger compartment.

Landspeeder. Speeder-scale, maneuverability 1D, move 115; 300 kmh, body strength 2D.

Transportation Off This Rock

The characters can find Bom Vimdin in the Cantina. At the gamemaster's discretion, the characters can also hire a smuggler they might have encountered in a previous adventure.

Vimdin is a cold, calculating individual who works for anyone with the credits. He seems disinterested unless the characters explain that Big Bunji is involved, in which case Vimdin will take the job for either 10,000 credits or four future unspecified smuggling cargoes. Wrex quickly agrees. Vimdin says that his ship, the *Blood Freeze*, is in Docking Bay 65; he tells them that he'll be ready to go as soon as they show up.

Bom Vimdin. *Dexterity 2D+1, blaster 3D+1, dodge 4D+1, melee combat 3D+2, melee parry 3D+1, pick pocket 4D, Knowledge 2D+1, alien species 3D, bureaucracy 3D+1, law enforcement 7D+1, streetwise 5D+1, value 4D, Mechanical 3D+2, astrogation 4D+2, repulsorlift operation 4D, space transports 4D, starship gunnery 5D, starship shields 3D+1, Perception 3D, bargain 7D, con 7D+2, gambling 3D+1, hide 4D, investigation 5D+2, search 3D+1, sneak 3D+2, Strength 3D, brawling 3D+1, climbing/jumping 3D+2, Technical 2D+2, computer programming/repair 3D, demolition 3D+1, repulsorlift repair 3D+2, security 8D+1, space transport repair 4D.* Force Points: 1. Character Points: 9. Move: 9. Equipment: blaster pistol (4D)

Blood Freeze. Ghtroc freighter, starfighter-scale, hyperdrive multiplier x2, maneuverability 1D, space 3, atmosphere 260; 750 kmh, hull 3D+2, shields 1D. Weapons: One double laser cannon (fire control 1D+2, damage 4D).

Planning the Rescue

The next morning, the characters are comlinked by Drayk or Nace and told that Bunji is being transported

in a hover-truck to Docking Bay 94 at 1000 hours. With the route and time in hand, the characters can set up their ambush.

Drayk also offers the characters Ccalras Corporation IDs, which they are supposed to drop at the scene. This will implicate Ccalras in this incident and prevent the characters from being identified (as long as they get away, that is). Drayk slyly comments, "This will keep Jabba busy!"

If they are under-powered, then Voushon suggests that the characters contact Kayson at his weapon shop; Kayson gives them a fair price if they mention they are helping Big Bunji.

The Ambush

This mission seems to be simple at first; the hover-truck appears to have no escort. However, things go horribly wrong once the rescue attempt begins: the hover-truck's doors open and 10 sandtroopers pour out of the vehicle, while two dozen security officers block the streets. The characters are informed that they're under arrest! (Needless to say, Garindan used his comlink or found other ways of spying on the characters, and reported their plans to Prefect Talmont.)

Just as things are beginning to look desperate, dozens of droids wander into the area, blocking the line of fire for the security guards and creating a lot of confusion. This gives the characters the opportunity to escape; while fleeing, they see Mace Windu and Aguilae in the alleys, chuckling to themselves as they observe the confusion their droids have created. (Windu is returning the favor for his previous rescue!)

One Last Chance

The characters are comlinked again and told that the prison shuttle is actually landing in Docking Bay 87 — and Bunji is already there! They have to hurry to rescue Bunji!

At the Docking Bay, the characters face very little opposition: there are only half a dozen guards and another four stormtroopers protecting Bunji.

Mos Eisley Security Officers. All stats 2D except: *blaster 3D, brawling parry 3D, dodge 4D, vehicle blasters 4D, intimidation 3D, survival 3D, beast riding 3D+1, command 3D, search 3D+2, brawling 3D.* Move: 10. Equipment: Blast vest (+1D physical, +1 energy), blaster pistol (4D), comlink, IDs

If the characters act quickly, they rescue Bunji and escape into the crowded alleys; if the characters are too slow or leave a trail, they are pursued through the city and a wild chase begins.

Getting the Cargo

Once free of the pursuing guards, Voushon explains to Big Bunji that the characters orchestrated his rescue — although they were working for Labria at first! Bunji sticks to the agreement Voushon made and offers to lead everyone to the cargo.



Christopher Trevas

Bunji leads the characters to a small antique shop, which has a hidden entrance to Mos Eisley's network of underground caverns.

Staging Tip. Depending upon the pacing wanted for this adventure, you can make picking up the cargo a simple matter ... or make finding the cargo just the beginning of the adventure!

You can have any number of encounters in the caverns. Perhaps someone has absconded with the cargo. The Mos Eisley Militia is now out in full force to find Bunji and may send an expedition down into the

caves. There may be any number of dangerous creatures and individuals hiding down here — Ranats, scurriers, womp rats, gangsters, rogue droids and so forth.

With the cargo in hand, the characters and Bunji race to Docking Bay 65, while trying to avoid security patrols and Garindan's agents. As he heads up the *Blood Freeze's* boarding ramp, Bunji offers the characters the espionage matrixes ... and promises to look them up again next time he's on-planet.

Harvest Day

Harvest Day is one of Mos Eisley's biggest times of celebration. Thousands of moisture farmers converge on the desert spaceport, their skills and landspeeders burdened with water canisters, homemade wares, and fruits and vegetables fresh from underground hydroponics stations. In this time of hectic negotiating and celebration, Mos Eisley's citizens and the visiting farmers congregate in every shop, market and pub. The streets are filled with vendors and peddlers; spacers, aliens, droids and every being imaginable look for deals on precious goods and gaudy trinkets.

However, with all the excitement comes trouble. Petty crime skyrockets as unscrupulous hoodlums engage in theft, vandalism and robbery. Tensions between moisture farmers and rowdy spacers, fueled by free-flowing spirits and the excitement in the air, erupt into brawls and blaster-duels.

With Harvest Day being tomorrow, the characters are approached by Mos Eisley Assistant Security Officer Predne Balu. Because of a shortage of officers — and knowing the kind of chaos that tends to erupt

during Harvest Day — he offers the characters 200 credits each if they'll serve as temporary militia and help maintain order. If the characters bargain, he offers a bonus of 25 credits per criminal who's rounded up for any serious offenses.

Staging Tips. Balu chooses the characters because it's assumed they've established their basic credibility and morality to him in previous adventures. For example, in "Vested Interest" they try to save Beeyon Nace from slavery. Even though they might have worked against Balu in the past, perhaps he likes the way they do things — and besides, everyone else has already turned Balu down and they're the only ones left who he'd trust with a badge!

A good motivation to get the characters involved is to have them being pursued by some of Mos Eisley's villainous thugs — Jabba's men, swoop gangers, or pirates will do. With the power of the law supporting them, the characters will have plenty of protection ... and they may even be able to bring these foes to justice.



Christopher Trevas

Training

Once the characters agree to the job, Balu takes them to the Mos Eisley Police Station for training. He goes through a quick review of Mos Eisley's laws. (See pages 21-22 of *Galaxy Guide 7*.)

Balu warns the characters to be cautious. Their job is to protect the citizens from harm; minor crimes are to be overlooked. He orders them to patrol the city — particularly the rough-and-tumble downtown starport area — and address situations as they encounter them. They can call for backup on their comlinks, but Balu makes it clear that he expects the characters to handle situations on their own. They have the authority to arrest anyone who's committed a serious offense, but for minor incidents their objective should be to calm everyone down and convince people to peacefully go about their business.

He issues each character a stun pistol (4D stun damage, 5/10/25), identification badges, a comlink secured to the police comm frequency, and a blast vest (tan with blue lettering indicating "Mos Eisley Militia"; the twin suns design of Mos Eisley is also in blue).

Balu warns the characters about the stormtroopers. He says that they're a nuisance because they can issue orders to just about everyone — including the characters. "They get their noses into the middle of every problem and just make things worse."

The Harvest Arrives

Harvest Day is a wild, city-wide event and things tend to get rather boisterous and rowdy. This adventure isn't about combat — although there are a lot of physical obstacles. Rather, communication and roleplaying are the best methods for resolving these situations. As representatives of the law, the characters are duty-bound to be good role models!

The key to making this an entertaining adventure is to keep the characters constantly moving. Characters have to deal with everything from mundane encounters — angry cantina patrons and petty thieves — to extremely dangerous situations. Perhaps the characters have to defuse a bomb, protect a smuggler from Imperial stormtroopers (Balu explains, "I don't want to know. If I don't know about it, I don't have to file a report on it."), or rescue a cargo of captured slaves from the clutches of Kollen Xa. Plot threads and subplots should continuously overlap: just as the characters are resolving one problem, another demands their attention. Never let them rest because there is so much going on!

This adventure is also a great chance to reintroduce old friends and enemies, or introduce new

characters who will be playing a role in future adventures. For example, the characters may meet Diew Rejeff, a fair-minded and wealthy merchant who figures prominently in the adventure "The Passage from Perdition." This adventure is also a great chance to introduce famous personalities, perhaps including cameos by Jabba the Hutt, Bib Fortuna and even Boba Fett.

Below is a list of several events that can happen during the day.

Bank Robbery

Three droids attempt to rob Zygian's Banking Concern, believing that the bank "robbed" their master of his land. The misguided machines are trying to help him, but Zygian's manager refuses to negotiate. One of the droids is obviously unstable and his "temper" is rising!

The characters have a number of options. They may have to find the owner, who can talk the droids into cooperating... but first the owner has to be convinced that he won't be carted off to jail due to the actions of his droids. Perhaps the characters can infiltrate the bank and find a way to slap restraining bolts onto the machines; or maybe some Jawas are willing to help deactivate the droids if they're allowed to keep them!

Running the Gauntlet Swoop Race

The characters are called in to stop two swoop gangs from "Running the Gauntlet." This "game" involves racing through Mos Eisley's crowded main streets as quickly as possible. Each swooper must dodge, ram and blast anything that gets in his way in an attempt to be the first one to the eastern edge of town. Of course, the swoopers aren't going to appreciate the characters stopping their fun!

Spooked Rontos

When a pair of rontos are spooked during the swoop race, it's up to the characters to stop them from stampeding into the main square! Can the characters and the rontos' Jawa owners calm down the massive creatures?

Lost Child

When a moisture farmer's small son is reported missing, it's up to the characters to find him. The true story can range from relatively innocent — he got lost and is now following a bunch of Jawas around — to much more sinister: perhaps slavers are trying to increase their stock!

Cantina Clamor

A fight erupts at the Cantina (or a similar spacer bar) and the aliens, swoopers and thugs are prepared to settle things with blasters. Just as the



Christopher Trevas



characters think they have things under control, stormtroopers arrive to help ... and cause even more trouble.

Berserkers ...

A large alien has had a little too much lum and he's spoiling for a fight; a swoop gang is willing to oblige. Unfortunately, the alien has some very equally large and angry friends lurking about ... and stun settings don't seem to be affecting them! Can the characters resolve this situation peacefully?

Domestic Dispute at the Inn

When a Rodian couple have a domestic dispute (about who gets to hunt a specific bounty), their tussle spills into the street. While civilians flee the trouble, the characters get to mediate the situation ... only to have the bounty in question wander by!

Out of Season

The characters are making a call when a bounty hunter tries to capture one of them. Imagine the hunter's surprise when he discovers that he just tried to capture a law officer!



The Passage From Perdition

Setting: The time is shortly after the death of Jabba the Hutt. While the Rebel fleet prepares for its assault on the Second Death Star, Mos Eisley is thrown into chaos in the aftermath of Jabba the Hutt's death.

Mos Eisley is in turmoil. The countless criminal gangs and flunkies, once held in check by the fear of Jabba's wrath, have turned upon each other, waging an open gang war for control of the city. Meanwhile, Imperial Prefect Talmont struggles to protect the citizens: stormtrooper patrols comb the streets trying to round up troublemakers, while Mos Eisley's unarmed citizens hide behind barricaded doors and windows, hoping for an end to the conflict.

This adventure is designed for characters who have reputations as upstanding, law-abiding citizens. Characters who did a good job during the adventure "Harvest Day" are particularly good for this adventure. The characters are contacted and asked to come to the Cantina.

At the Cantina

The characters are in the Cantina, which Chalmun is rebuilding after a recent firebombing attack by swoop gangers. Chalmun directs the remodelers, including several droids, much to the Wookiee's displeasure. With Wuher the bartender translating, Chalmun explains that Diew Rejeff, a merchant and a good friend of his, disappeared three days ago. Diew is a prominent citizen with wealth and a strong desire to drive the Empire from Tatooine: he could rally the citizens to drive out the gangsters and depose Prefect Talmont, allowing Tatooine to be a free world. Diew's off-world trading contacts would bring in enough business to keep Mos Eisley's economy stable.

As Chalmun and Wuher conclude, the characters hear the sound of swoops racing by. A small firebomb bounces into the doorway, but two Artoo droids put the fires out quickly with their extinguishers.

Chalmun, enraged by this attack, races out into the street and pulls one of the taunting swoopers from his vehicle. Five more swoop gangers close in on Chalmun,

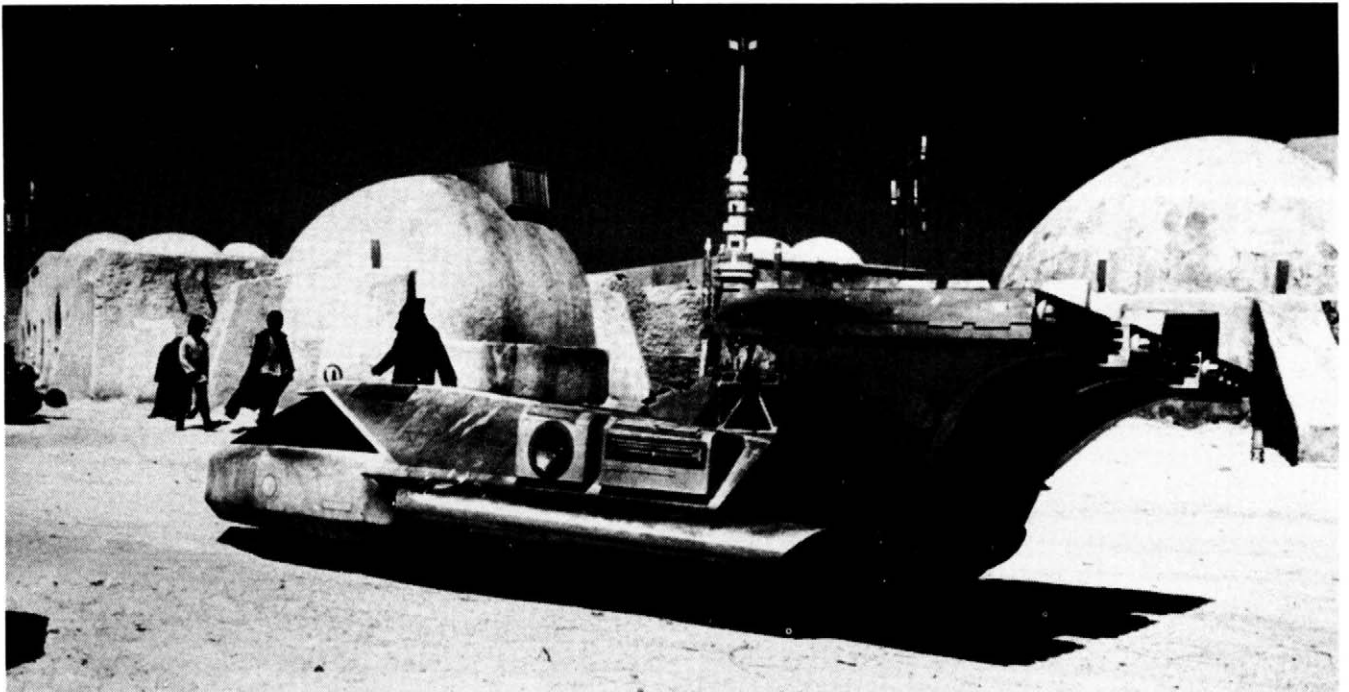



intending to kill the enraged Wookiee. (Chalmun's stats are on page 54 of *Galaxy Guide 7*.)

Typical Swoop Trooper. All stats 2D except: *blaster 4D+2, dodge 3D, melee combat 4D, intimidation 3D, streetwise 2D+2, swoop operation 5D, brawling 4D+2*. Move: 10. Equipment: Blaster pistol (4D), various melee weapons (STR+2 to STR+3D), swoop.

The characters (or other concerned citizens) move to save the Wookiee. As the swoops depart, one ganger identifies himself as "Mossol the Menace." He throws down a small tube and races away.

The tube contains a flimsiplast sheet which says, "We are holding Rejeff. We want 50,000 credits by sun-up tomorrow or we kill him. Meet us outside the Lucky Despot. Don't try anything foolish — it would be a waste to have to kill your friend!"

Chalmun is quite concerned and asks the characters to see if they can find out where the swoopers are holding Rejeff and rescue him. Chalmun and the others will try to get the Imperials to investigate and gather the ransom money, although Chalmun is extremely upset at the prospect of paying ransom money to a bunch of thugs.

Chalmun directs the characters to Abbot Drayk of the Dim-U Monastery and Valarian, the Whipid who owns the Lucky Despot. Both of them might have information.

On the Street

Mos Eisley is under siege. Citizens shuffle along fearfully, ever wary of the whine of swoop motors. Stormtroopers check everyone's identity card and give the locals a hard time about the slightest infractions. When stormtroopers aren't around, the gangsters and swoopers emerge from the shadows, continuing their turf war.

Abbot Drayk. Having been under constant attack since the fighting began, Abbot Drayk and his "monks" know very little about Rejeff. However, he says that he and his monks will be alert for information; he gives them a comlink (if they don't already have one) so he can contact them if something pops up.

Lady Valarian. The Whipid crime lord is uncooperative at first, but if the characters are persistent she helps them out. Valarian reveals that she established a treaty with Swang, leader of one of the more dangerous swoop gangs. Valarian says the deal was simple — she stays out of his business, and he and his thugs don't bother her operations. However, Swang has already proven far too greedy, attacking several stores that were under her protection. Valarian says she'd much rather see his reign come to an abrupt end.

She tells them that some of her "eyes" saw Swang himself come into the city on the day Rejeff disappeared; he headed to Jabba's townhouse, which the gang appeared to have claimed. She knows the swoopers took at least one prisoner to the townhouse. By the next morning, all the swoopers were gone,

having left sometime during the night. Since then, Swang hasn't been seen or heard from, but his men continue their raids.

Jabba's Townhouse

The characters must again negotiate the dangerous streets of Mos Eisley to get to Jabba's townhouse. While a few sturdy swoop gang members guard the place, their security is far from perfect; quick-thinking characters should be able to use grapples to get onto the roof or climb up to a window. If the characters take the direct approach, these guards put up a good fight but they flee if two or more are wounded.

Once inside the townhouse, the characters find that the building has been cleaned out. All computers and records are gone. All furnishings have been removed. There are many blaster holes in the walls and floors — there was a savage battle for control of the townhouse. (For the layout of the townhouse, see pages 45–50 of *Galaxy Guide 7*.)

The characters are attacked by a dozen kayven whistlers. These creatures, set free during the battle, hid when they heard the characters enter the townhouse. Once the whistlers realized that only a few people were in the building, their great appetites took control.

If the characters search the nests of these voracious beasts (near the ceiling of the audience chamber), the characters spot Rejeff's comlink and identity card.

Kayven Whistlers. *Dexterity 4D, brawling parry 6D, Perception 2D, Strength 4D, brawling 6D*. Move: 15. Razed teeth (STR+2D damage).

There is a blasted servant droid in the last guest room. If they power up the droid (Very Easy *droid repair* roll), the droid begins reciting the last few seconds before it was blasted. The droid has an abrasive, haughty and quite evil personality. Read aloud:

"The master will be very upset that you stole the maps to his bunkers in the Swallowing Wastes. And holding Merchant Rejeff for ransom — he's been paying Master Jabba protection money for years. Jabba will feed you to the rancor for this!"

Very soon the droid comes to its senses and demands to know who the characters are and what they're doing here. The droid is quite dismayed if it learns that Jabba is dead, although it mutters to itself that it should be able to make a fortune off the gullible citizens of the city. The droid refuses to cooperate further; if the characters decide to bring it along with them, it causes no end of trouble.

Staging Tips. This droid — which refuses to divulge its name — is exceptionally obnoxious and mean-spirited. It seems to have greatly enjoyed serving Jabba. Play this droid so that the characters will want to blast it just to get it to shut up.

Within moments, Abbot Drayk calls them on the comlink. He explains that he just intercepted a sub-

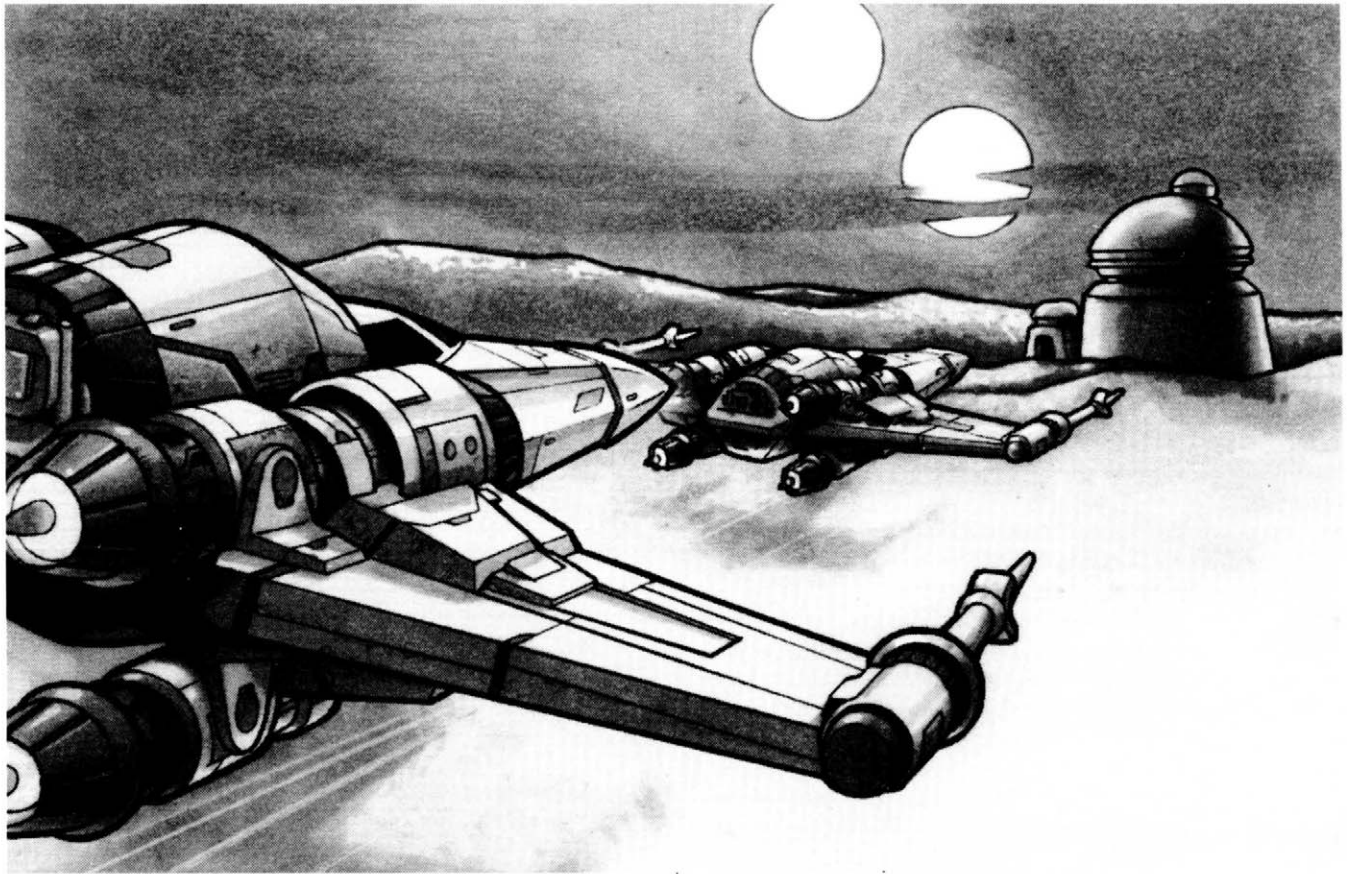

Christopher Trevas

space conversation between Prefect Talmont and an Imperial Customs corvette which appeared in-system a few moments ago.

Drayk plays the conversation aloud: the Customs corvette explains that no reinforcements are available as Imperial forces are otherwise occupied. Talmont sounds desperate, explaining that he can't keep the gang war going forever; he needs more forces to impose martial law on the city or else the citizens will rise up and cast him out of power when they find out about what happened at Endor.

Drayk points out that if the city's residents found out that Drayk was encouraging the gang war, he'd have a revolution on his hands. When the characters mention Jabba's bunker in the Swallowing Wastes, Drayk summons them back to the Dim-U Monastery, where he outfits them with a landspeeder and a portable scanner.

Out in the Wastes

The characters must search the Swallowing Wastes for the bunker. The barren area, far to the east of Mos Eisley, is considered as dangerous as the Jundland Wastes. It's rumored that the area is populated by Tusken Raiders.

Staging Tips. You can allow the characters to find the bunker with relatively few complications, or you may have them encounter Sand People, a starship

wreck, moisture farmers, and perhaps even a swoop gang patrol headed to the bunker.

The scanner detects Jabba's bunker from two kilometers away. The mountains offer the characters plenty of cover to sneak up on the complex, which consists of an egg-shaped building. The scanner detects massive power readings, suggesting that much of the bunker is underground. Guards roam the perimeter in pairs.

While the characters are checking out the bunker, they hear the roar of starship engines. Within moments, six Z-95 Headhunter starfighters zoom overhead, heading towards the bunker. The mountainside suddenly parts to reveal a perfectly camouflaged hangar bay.

Staging Tips. Hopefully, the characters hid their landspeeder before the Z-95s arrived. While the Z-95s weren't scanning for vehicles, if the speeder was out in the open, you could decide that one of the Z-95 pilots spotted the speeder and reported it to Swang. In this case, a patrol of five swoops comes out to investigate — although this may give the characters a chance to subdue the none-too-bright swoop riders.

Swoops. Speeder-scale, maneuverability 4D, move 210; 610 kmh, body strength 1D.

Z-95 Headhunters. Starfighter-scale, maneuverability 1D, space 6, atmosphere 330; 950 kmh, hull 4D, shields 1D. Weapons: 2 triple blasters (fire control 1D,



damage 3D), concussion missiles (fire control 1D, damage 7D).

The characters have many ways of getting inside the bunker. They might try to slip through security, or they might be able to disguise themselves as swoopers and race right inside.

Inside the Bunker

The bunker extends far underground. There are numerous patrols, but most of the guards are lazy and poorly-trained: unless the characters draw attention to themselves, none of the guards suspect that the characters don't belong there.

When one of the guard patrols passes by, the characters overhear the guards talking amongst themselves. One mentions Swang taking a "rich Mos Eisley merchant" for ransom; he's being held down in the prisoner cells on the bottom level.

The other guard laughs and says he wonders what Swang will do with the ransom money — and with the merchant's body. "There's no way he's going to let Rejeff live. He's too dangerous for Swang to let him go."

A third guard jokes that it won't matter much, since Swang is going to use the Z-95 fighters to bomb Mos Eisley and wipe out the Imperials and gangsters who are fighting him. "And he'll bomb anyone else who stands up to him! Swang's going to rule Mos Eisley or he's going to burn the place down!"

Completing the Rescue

Rather than dictate a specific course of action, this section outlines a few of the players' options, along with guidelines for the final situation at the end of the battle.

If the characters try to rescue Rejeff, they must skirt numerous patrols and incapacitate Rejeff's guards

before they sound the alarm. The characters may escape using their landspeeder, swoops or even the Z-95s; most likely, Swang's men follow, leading to a rousing chase across the desert.

The characters can use their comlink to call Drayk for assistance. While several smuggler ships soon arrive to destroy the bunker and the hangar bay, the characters are discovered by Swang's men and must somehow escape from the bunker before it is destroyed.

Conclusion. The conclusion of this adventure should set up the following situations:

- Diew Rejeff should arrive in Mos Eisley, safe and unharmed.
- Swang should still be alive — with much of his organization intact — but his Z-95s are destroyed or otherwise prevented from bombing Mos Eisley.

During the brief celebration after Rejeff's return, a human claiming to be a member of the Rebel Alliance arrives. He introduces himself as Voren Na'al, Rebel Alliance Historian, and announces that the Emperor was killed in a battle in the remote Endor system. The Rebel Alliance has won the war against the Empire!

Soon thereafter, Abbot Drayk plays the conversation he recorded earlier between Prefect Talmont and the Imperial Customs corvette. Almost immediately, an attack plan is drawn up by Chalmun, Rejeff and Assistant Security Officer Predne Balu (who announces that he's tired of Talmont's corruption and is joining with the citizens). The citizens of Mos Eisley must defeat the Empire and the swoop gangers!

Cut to the *Star Wars Miniatures Battles* scenario "A Line in the Sand."

A Line in the Sand...

A Star Wars Miniatures Battles Scenario

The Alliance has recently won the Battle of Endor and the Emperor is dead. The residents of Mos Eisley rally to the Alliance's cause in celebration ... and decide to end the Empire's rule on their world!

The Situation

This is a miniatures battles scenario for three players: one player controls the Imperial forces, the second controls the Mos Eisley Militia forces, and the final player controls Swang's swoop gangs.

With angry citizens on the march, Prefect Talmont has decided that discretion is the better part of valor ... and probably a good way to stay alive. He and his bodyguards have fled to Docking Bay 87 to await the arrival of their escape shuttle. Unfortunately for Talmont, Mos Eisley's residents know where he is and have decided to attack the bay in hopes of capturing him. Meanwhile, a group of swoopers have decided that they shouldn't be left out of the fun and decide to join the battle!

Imperial Forces

The Imperials consist of three squads of sandtroopers, Prefect Talmont, and his personal bodyguard droid, an Arakyd BT-16 attack unit.

■ Guardian Squad

■ Sentinel Squad

■ Protector Squad

- 10 Average Sandtroopers
- DEX (1), *blaster* (3), *grenade* (2), *melee combat* (2); KNO 2; MEC 2; PER 2; STR 2 (3), *brawling* 4; TEC 2; Move: 10.
- **Walk Rate:** 6"; **Run Rate:** 11".
- **Weapons:** blaster rifle.
- **Specialist:** blaster (4).
- **Weapon:** repeating blaster (non-tripod).
- **Squad Generation Points:** 534.

■ Arakyd BT-16 Attack Droid

- **Type:** Modified Attack Droid
- DEX 4, *blaster* 6; KNO 1; MEC 1; PER 1; STR 5 (6); TEC 1; Move: 14.
- **Walk Rate:** 11"; **Run Rate:** 18".
- **Weapons:** Taim & Bak repeating blaster (360° turret).
- **Squad Generation Points:** 97.

The droid is programmed to protect Talmont and may not move more than 4" away from him.

■ Prefect Talmont

- Imperial Prefect
- DEX 3, *dodge* 5; KNO 4; MEC 2, *beast riding* 5; PER 3, *command* 5; STR 2; TEC 3; Move: 10.
- **Walk Rate:** 8"; **Run Rate:** 13".
- **Weapons:** None
- **Squad Generation Points:** 68

Prefect Talmont is a coward; consequently, he may not defend himself or otherwise battle anyone. If any enemy figures (militia troops or swoop gangers) come within 1" of him, he is *automatically* captured. Otherwise, all normal rules for capturing and guarding prisoners apply, as per page 41 of the *Star Wars Miniatures Battles Companion*.

Mos Eisley Militia

The militia group is determined to capture Prefect Talmont and put him on trial for his crimes against the people of Mos Eisley.

There are three squads and three heroes. At the beginning of the battle, Chalmun commands the Cantina Commandos, Predne Balu commands the Mos Eisley Security Squad, and Diew Rejeff commands the Rejeff's Legion squad. However, command may be delegated to soldiers within the squads so the three heroes can act on their own.

■ Chalmun the Wookiee

- Mos Eisley Hero
- DEX 2, *bowcaster* 6, *dodge* 3, *grenade* 3, *melee combat* 3; KNO 2; MEC 2, *beast riding* 4; PER 2, *command* 5; STR 4, *brawling* 6; TEC 2; Move: 10.
- **Walk Rate:** 7"; **Run Rate:** 12".
- **Weapons:** Bowcaster, 2 grenades.
- **Squad Generation Points:** 93.

■ Predne Balu

- Mos Eisley Hero
- DEX 4, *blaster* 6, *dodge* 5, *melee combat* 5; KNO 3, *streetwise* 4; MEC 3; PER 4, *command* 5; STR 2, *brawling* 4; TEC 2; Move: 10.
- **Walk Rate:** 9"; **Run Rate:** 14".
- **Weapons:** Blaster rifle, 2 grenades, vibroblade
- **Squad Generation Points:** 100

■ Diew Rejeff

- Mos Eisley Hero
- DEX 3, *blaster* 5, *dodge* 5; KNO 2; MEC 3; PER 4, *command* 5; STR 3; TEC 3; Move: 10.

- **Walk Rate:** 8"; **Run Rate:** 13".
- **Weapons:** Blaster rifle, 2 grenades, vibroblade.
- **Squad Generation Points:** 90.

■ Cantina Commandos

■ Mos Eisley Security

■ Rejeff's Legion

- 10 Average Troopers
- DEX 3, *blaster 5*; KNO 2; MEC 2; PER 2, *command 3*; STR 2, *brawling 3*; TEC 2; Move: 10.
- **Walk Rate:** 8"; **Run Rate:** 13".
- **Weapons:** blaster pistol.
- **Squad Generation Points:** 340.

Swang's Swoop Gang

Swang's swoop gang, led by Mossol the Menace, simply wants to cause as much trouble as possible. In addition to Mossol, there are seven other swoops and their riders. They've set their sights on capturing Prefect Talmont ... and if they can get their hands on any of the Militia heroes as well, that would make the battle even sweeter.

■ Mossol the Menace

- Swoop Thug
- DEX 3, *blaster 5*, *dodge 5*, *grenade 5*; KNO 2; MEC 3, *repulsorlift operation 6*; PER 4, *command 5*; STR 3; TEC 3; Move: 10.
- **Walk Rate:** 8"; **Run Rate:** 13".
- **Weapons:** Blaster rifle, 4 grenades, vibroblade.
- **Squad Generation Points:** 114.

■ Swoop Gangers

- 7 Veteran Swoopers
- DEX 3, *blaster 5*; KNO 2; MEC 2, *repulsorlift operation 5*; PER 2, *command 4*; STR 3, *brawling 4*; TEC 2; Move: 10.
- **Walk Rate:** 8"; **Run Rate:** 13".
- **Weapons:** Blaster rifle.
- **Commander:** *command 5*.
- **Squad Generation Points:** 343.

■ Swoops (8)

- **Drive System:** Repulsorlift
- **Crew:** 1.
- **Passengers:** 1.
- **# Turns:** 3.
- **Turn Distance:** 2.
- **Move:** 140.
- **Cautious Speed:** 14.
- **Cruise Speed:** 42.
- **Top Speed:** 140.
- **Accel/Decel:** 14/14.
- **Flight Ceiling:** 10 meters.
- **Body Strength:** 1.
- **Body Points:** 10.
- **Cover:** 4.
- **Squad Generation Points:** 824

The Battlefield

The map printed here is one-quarter actual miniatures battle scale. (One inch on this map represents eight meters.)

The battle takes place inside Docking Bay 87. The walls of the bay are sheer, smooth surfaced plascrete that cannot be climbed. The walls are one level tall; the swoops can get into the bay by flying over the walls.

The bay's floor is clear terrain, except for the cargo

containers strewn all over the bay floor. The crates are waist-high, so they provide medium cover; for figures trying to climb over the crates, the crates count as difficult barriers. These crates may be moved; the figure must be in base-to-base contact with the crate and cannot attack that round. One figure can move a crate at one-half his or her walk rate. Two figures working together can move a crate their full walk rate (if the walk rates are different, use the lower of the two numbers).

Cargo Doors

Docking Bay 87 has a Primary Cargo Door (on the west) and three Secondary Cargo Doors (on the north, east, and south). Each has large, sliding doors. Each door has controls panels on both the outside and the inside of the docking bay (control panels are indicated on the map).

A figure must be in base-to-base contact with a control panel for a full turn to activate a cargo door; the panel controls the nearest door. Once a panel is activated, the door must completely open or close before the panel can be activated again.

The Primary Cargo Door opens at the end of the turn when its control panel is activated. The three Secondary Cargo Doors open at the end of the *next* turn after the control panel is activated.

Terrain Features

There are a number of doors which enter into Docking Bay 87. Entry Door 1 leads to Entry Door 2 and Entry Door 3, both of which are on the bay's floor level. Stairwell 1 leads to Entry Door 4, which emerges on the bay's floor level. Stairwell 2 leads to the Balcony, which provides medium cover. (Remember that stairs are considered rough terrain.)

Because of the cramped corridors, a maximum of three figures may pass through a door in one round.

The Set-Up

The Imperial player places his forces first; all figures must be inside Docking Bay 87. (They may not be on the balcony or inside the doors; they must be out in the open, on the docking bay floor.)

The Imperial player must place all crate counters within the outer landing circle. The Imperial player secretly marks two crates with an "X"; these crates contain grenades.

The grenades are inactive until an Imperial figure arms them by spending a full turn adjacent to a crate; the character may take no other action in the turn.

The bomb is now active. When the bombs are active, any figure that comes within 1" of the crate activates the bomb, which explodes with a Damage Strength of 7 and affects everything within 2.5". (Use the "Grenade Burst Area of Effect Template: 2.5" Radius" to determine which figures are affected by the blast.)

The Rebel forces set up second. Rebel units may be set up anywhere outside Docking Bay 87.

Swang's Swoop Gang sets up last. All swoop gangers must be within the Swoop Gang Set-Up Area.



Orders of the Day Mos Eisley Militia

Commander. Imperial Prefect Talmont is on the run from your forces. Intelligence reports that he and several squads of stormtroopers are hiding in Docking Bay 87 while awaiting a rescue shuttle.

You have three squads and three heroes. Set up each squad on the street outside Docking Bay 87. You have several means of entry into the Docking Bay, including stairs, sliding cargo doors and a balcony overlooking the bay.

Victory. Capture Prefect Talmont so he may be put on trial. (Talmont is automatically captured if any of your soldiers approach within 1" of him.)



Orders of the Day Imperial Commander 669.462/S2

Commander. You have been ordered to protect and escort Prefect Talmont during the evacuation of Mos Eisley.

Your men may not leave the Docking Bay, although they may move crates to set up cover. You may open and close the cargo doors using the control panels indicated on the map.

The Arakyd security droid must remain within 4" of Prefect Talmont at all times. Talmont is automatically captured if any enemy soldiers approach within 1" of him.

The rescue shuttle cannot land unless all crates are moved outside the Outer Landing Circle.

Victory. Get Prefect Talmont to the rescue shuttle when it lands.



Orders of the Day Swang's Swoopers

Mossol the Menace. Today is a good day to burn Mos Eisley down to the ground! Swang and the gang are busy looting other parts of the city, so it's up to you to make your mark by taking out Prefect Talmont and those do-gooder militia heroes.

Victory. You achieve a complete victory if you capture or kill **both** Prefect Talmont and one of the Militia heroes: Chalmun, Predne Balu or Diew Rejeff.

You achieve a minor victory if you capture or kill one of these individuals.

Complications

At the beginning of the game, roll two dice and add five to the result. This gives you a total between seven and 17 — this is the number of rounds until the rescue shuttle arrives.

If all crates are outside the Outer Landing Circle, the shuttle lands in Docking Bay 86. If Prefect Talmont is uninjured and not captured by the enemy, the Imperial player wins the game.

However, if any crates are still within the Outer Landing Circle, the shuttle *diverts* to Docking Bay 86 (across the street). In this case, give the Imperial player the following orders of the day.



Orders of the Day Imperial Commander 669.462/S2

Read Aloud to All Other Players. In the heat of battle, you overhear a stormtrooper squad leader shout, "The rescue shuttle has diverted to Docking Bay 86! We have to get the Prefect out of here!"

Your troops may now leave the docking bay.

Victory. You must get Prefect Talmont to the entrance to Docking Bay 86, where he boards his rescue shuttle.



Swoop
Gang Set-
up Area

Docking Bay 86
Entry Door

Control
Panel

Control
Panel

Primary Cargo
Door

Control
Panel

Entry
Door 3

Entry
Door 2

Entry
Door 4

Stairway 1

Entry
Door
1

1 inch = 8 meters

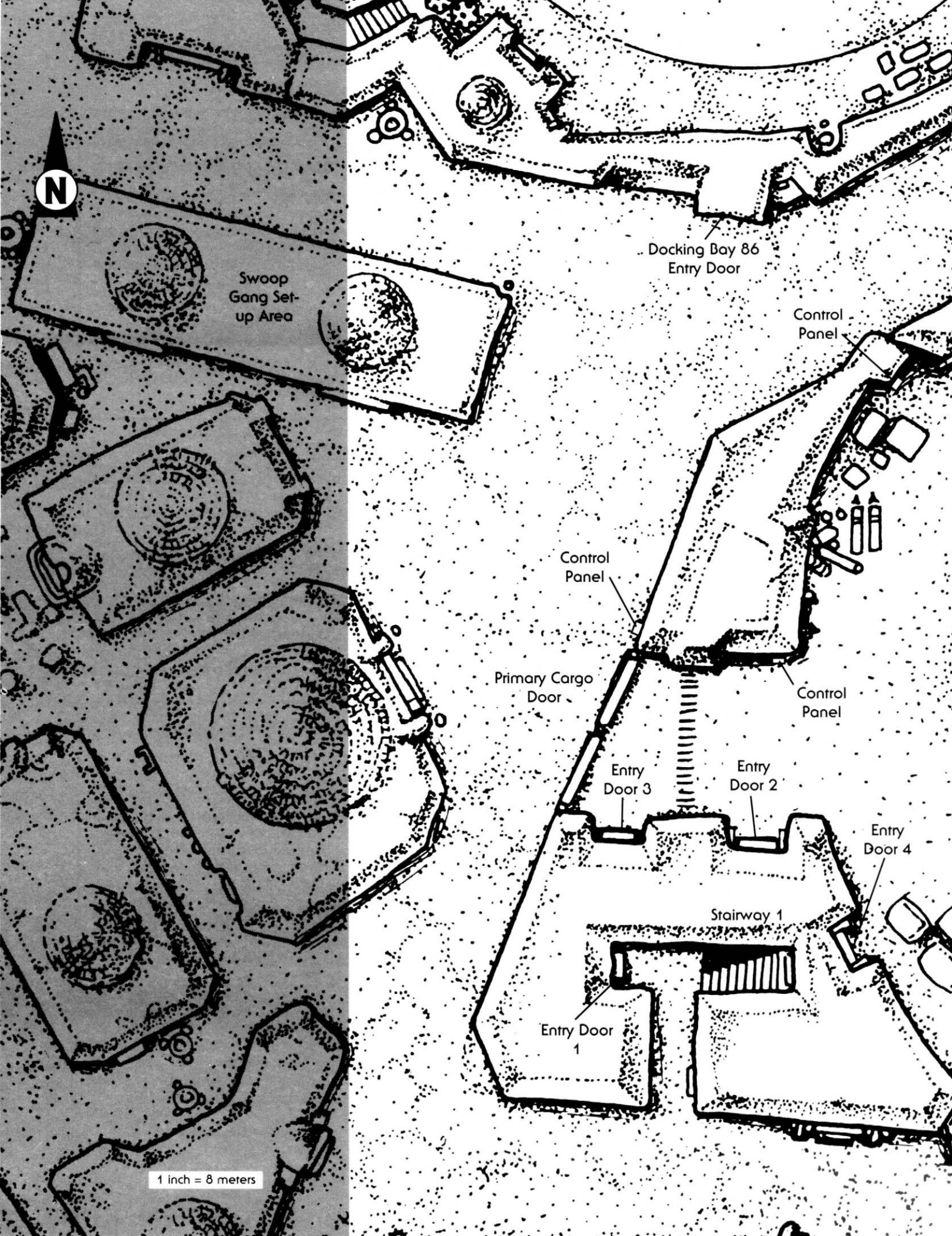

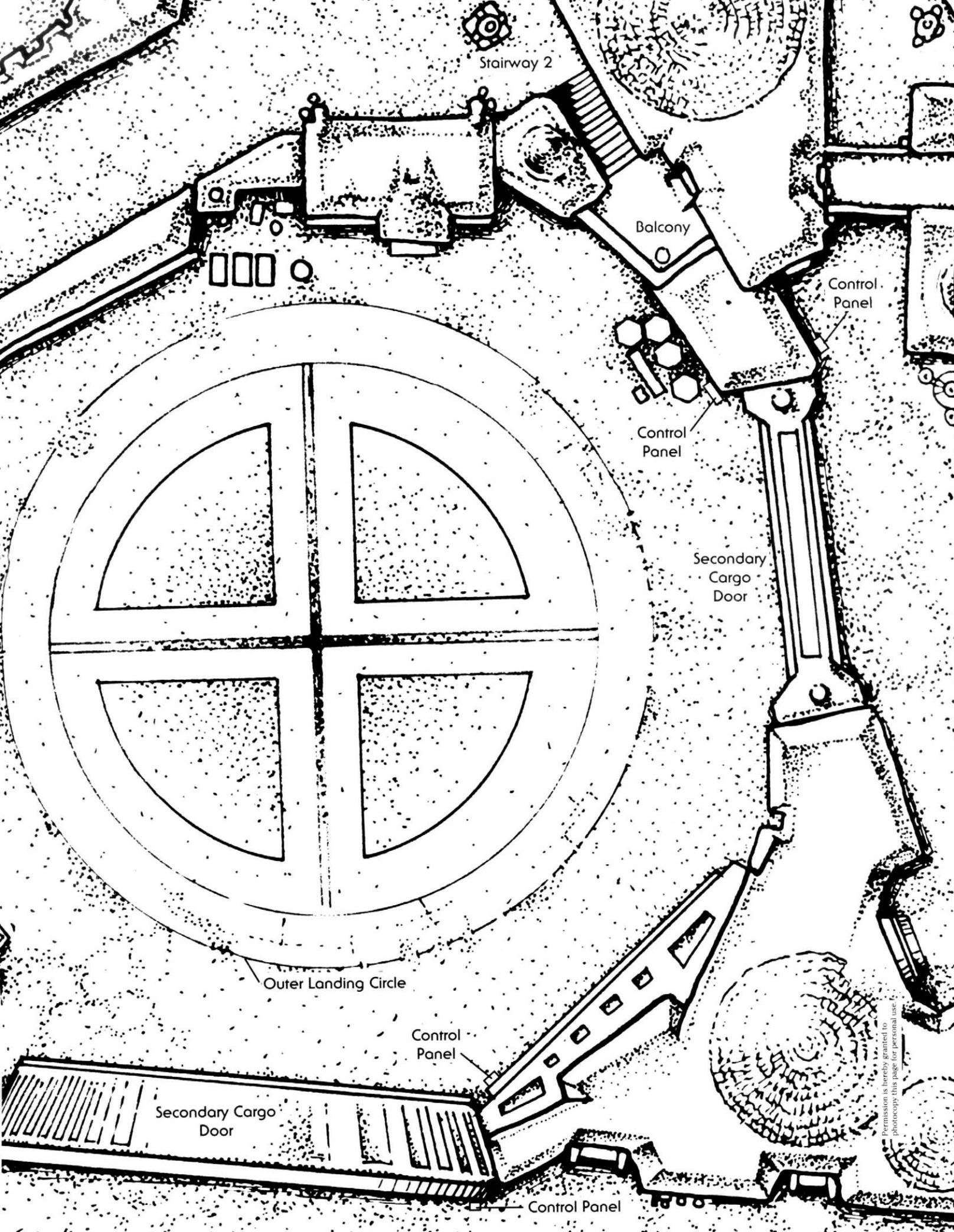

Stairway 2

Balcony

Control Panel

Control Panel

Secondary Cargo Door











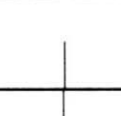

Outer Landing Circle

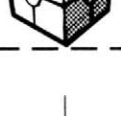
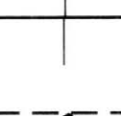
Control Panel

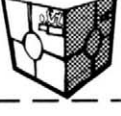
Secondary Cargo Door

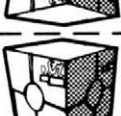
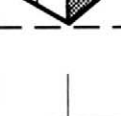
Control Panel

Permission is hereby granted to photocopy this page for personal use.

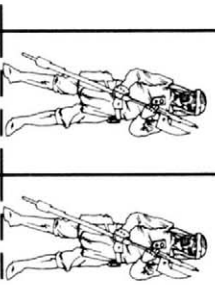
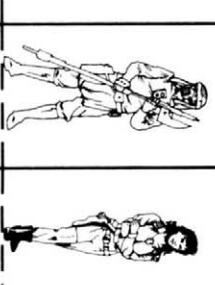
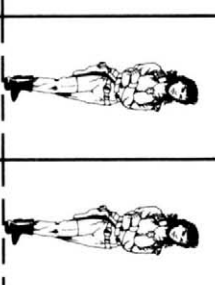
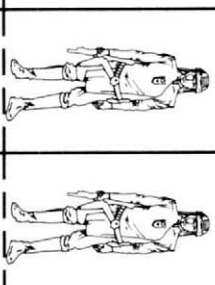
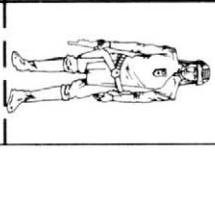
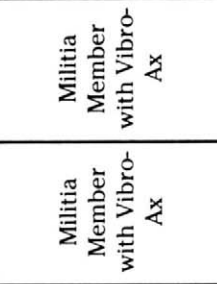
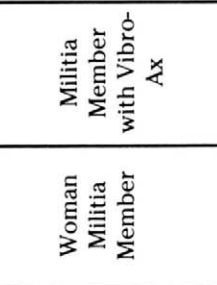
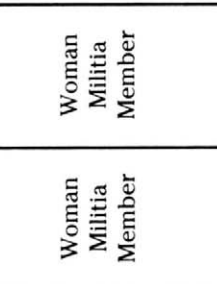
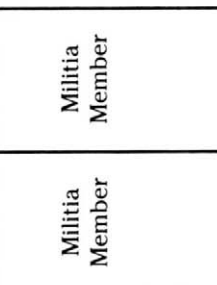
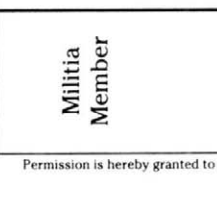
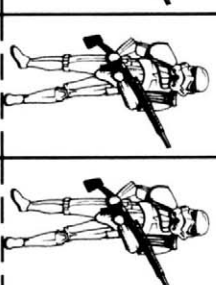
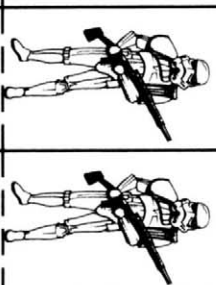
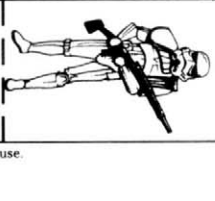
																			
																			
Militia Member	Militia Member	Militia Member	Militia Member	Woman Militia Member	Woman Militia Member	Woman Militia Member	Militia Member	Militia Member	Militia Member	Militia Member	Militia Member	Militia Member	Militia Member	Militia Member	Militia Member	Militia Member	Militia Member	Militia Member	Militia Member
																			
Swoop	Swoop	Swoop	Swoop	Swoop	Swoop	Swoop	Swoop	Swoop	Swoop	Swoop	Swoop	Swoop	Swoop	Swoop	Swoop	Swoop	Swoop	Swoop	Swoop
																			
Diew Rejeff	Sand-trooper	Sand-trooper	Sand-trooper	Sand-trooper	Sand-trooper	Sand-trooper	Sand-trooper	Sand-trooper	Sand-trooper	Sand-trooper	Sand-trooper	Sand-trooper	Sand-trooper	Sand-trooper	Sand-trooper	Sand-trooper	Sand-trooper	Sand-trooper	Sand-trooper



Adventure Hooks

These adventure hooks are set after *Return of the Jedi*; the specific timing of these adventures is dependent upon the needs of your campaign.

As shown in “The Passage from Perdition” and “A Line in the Sand,” after Jabba’s death, Mos Eisley is the site of a horrible gang war. However, the people soon unite, driving both the gangsters and the Empire out of their city. An era of peace arrives, as celebrations are held across the city.

However, the future is perilous for this desert spaceport. After the declaration of the New Republic, Tatooine is still in a period of upheaval. The planet’s new government is tenuously allied with the New Republic, but criminal interests still play a strong role in day-to-day life on the desert world. While Jabba’s empire is shattered, many newcomers are eager to carve out their own niche. The Empire no longer rules this planet, but a number of Imperial weapons caches are hidden deep in the desert ... and Imperial sympathizers are numerous. The limited series *X-Wing Rogue Squadron: Battleground: Tatooine* from Dark Horse Comics provides excellent background information on Tatooine during this time period.

Trouble in the Desert

The characters are in a small moisture farming village when they hear stories of recent Tusken Raider attacks on outlying farms. They are befriended by one of the local families and asked (or hired) to defend their farm.

During the night, the farm is attacked and many of the moisture vaporators are destroyed. The family faces financial ruin.

The next morning, another farmer — Walt Brennorn — comes around to explain that he’s forming a town militia. Everyone who pays dues of 400 credits per month will be protected; everyone who declines is on their own.

The Real Story. Some of the recent raider attacks are real ... but other attacks are being staged by thugs hired by Brennorn. Walt is allied with one of the new crime lords in Mos Eisley and he plans to stir up trouble and extort money from his neighbors.

If the farmers won’t pay for protection, Brennorn’s thugs stage “Tusken Raider” attacks and destroy as much machinery as possible. Brennorn reasons that most of the farms will have to declare bankruptcy, so he will be able to buy up the land for a pittance.

Brennorn has also riled up the local Tusken population by attacking them. Just as the characters begin to figure out who’s really causing trouble, the real Tusken Raiders decide to get vengeance and attack some of the local moisture farms. Can the characters protect the farms and expose Brennorn as the cause of the trouble?

Tusken Raiders. All stats 2D except: *Dexterity* 2D+1, *blaster*: blaster carbine 3D+1, *brawling parry* 4D+1, *dodge* 4D+1, *melee combat*: gaffi stick 4D, *survival* 4D, *survival: desert* 5D+2, *Mechanical* 1D, *beast riding* 3D, *beast riding*:

bantha 4D+2, *hide* 2D+1, *search* 2D+2, *sneak* 3D+1, *Strength* 3D+2, *brawling* 4D+2, *lifting* 4D+2, *stamina* 4D, *Technical* 1D. Move: 10. Equipment: blaster carbine (5D), gaffi stick (STR+2D), breath mask.

Murder by Droid

Mace Windu’s droids are killing their owners. The Mos Eisley Police throw the poor Squib droid broker in prison, assuming that he is responsible for the attacks.

The characters just bought a new droid from Mace, and when they go to check the programming they find more than they bargained for ...

The Real Story. Upon checking their droid’s programming, the characters discover that one of the “junk-droids” Windu bought from the Jawas was once an interpreter droid of Jabba the Hutt’s. However, the droid was tortured for Jabba’s pleasure! Now the droid sees every being except Mace (who helped repair him) as a minion of Jabba the Hutt. And all of Jabba’s allies must die!

For Your Visual Organs Only...

New Republic Intelligence (NRI) sends the characters to investigate the possibility of an unknown alien ship crashing on Tatooine! This is a top-secret mission — rumors suggest that the ship may belong to a strange alien species named the “Ssi-ruuk”!











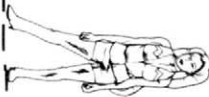





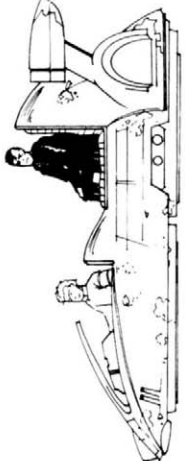
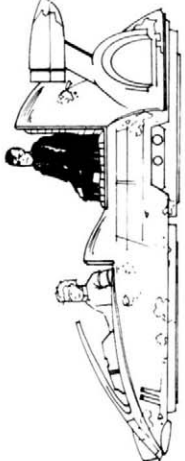





(Since the “Bakura Incident” is considered classified by the New Republic, the characters will probably need a briefing. See the Bantam novel *The Truce at Bakura* as well as *The Truce at Bakura Sourcebook* for more information.)

The Real Story. It wasn’t a Ssi-ruuvi ship that crashed in the Jundland Wastes ... but a Charon Death Cult scout ship! The ship is badly damaged and many of the Charon aboard were killed. Jawa sandcrawler tracks lead away from the wreck.

Unknown to the characters, the Jawas took in several injured Charon warriors; when the warriors returned to consciousness, they overpowered and killed the Jawas. After destroying the sandcrawler, the Charon warriors set out on foot for the nearby town of Bestine. Can the heroes defeat the insectoids before they have a chance to spread their “news” by killing all the inhabitants of Bestine?

Charon Warriors. All stats 2D except: *Dexterity* 4D, *blaster* 4D, *dodge* 5D, *survival* 3D, *Perception* 4D, *search* 4D+2, *sneak* 6D, *Strength* 4D, *brawling* 4D+1. Special Attacks: Poison claw attack (STR+1D, victim must make a Moderate *stamina* roll, failure results in an additional wound; Charon must spend one round secreting poison.). Equipment: Web spinneret (traps victim, body strength 3D+1), plasma blaster (4D).

For more information on the Charon, see *Galaxy Guide 4: Alien Races*, *Otherspace* and *Otherspace II: Invasion*.

																																											
Twi'lek Woman		Kayven Whistler		Rodian Thug		Gran Thug		Gotal		Swoop		Landspeeder		Arakyd BT-16 Security Drpoid		Arcona		Whiphid		Tusken Raider		Jawa		Beeyon Nace		Mace Windu		Mos Eisley Militia with Vibro-ax		Mos Eisley Militia		Duro		Bom Vimdin		Snaggletooth		Myo the Abyssin		Dr. Evazan		Ponda Baba	

STAR WARS®

GALAXY GUIDE 7 MOS EISLEY

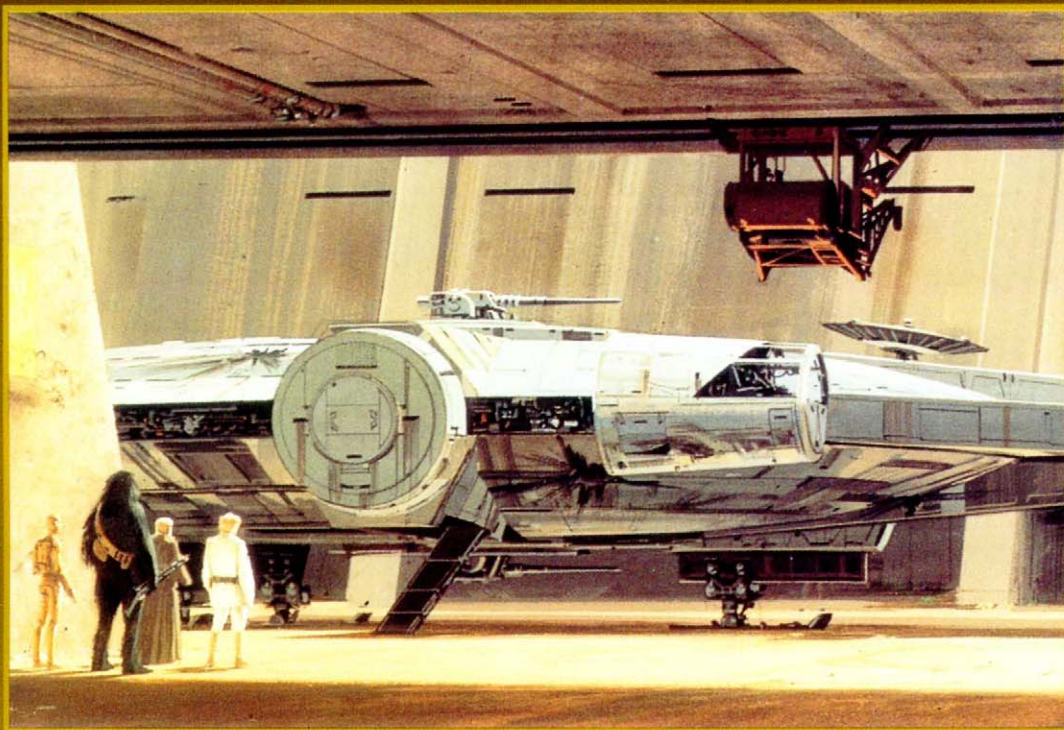

STAR WARS®

G A L A X Y G U I D E 7

MOS EISLEY

by Martin Wixted

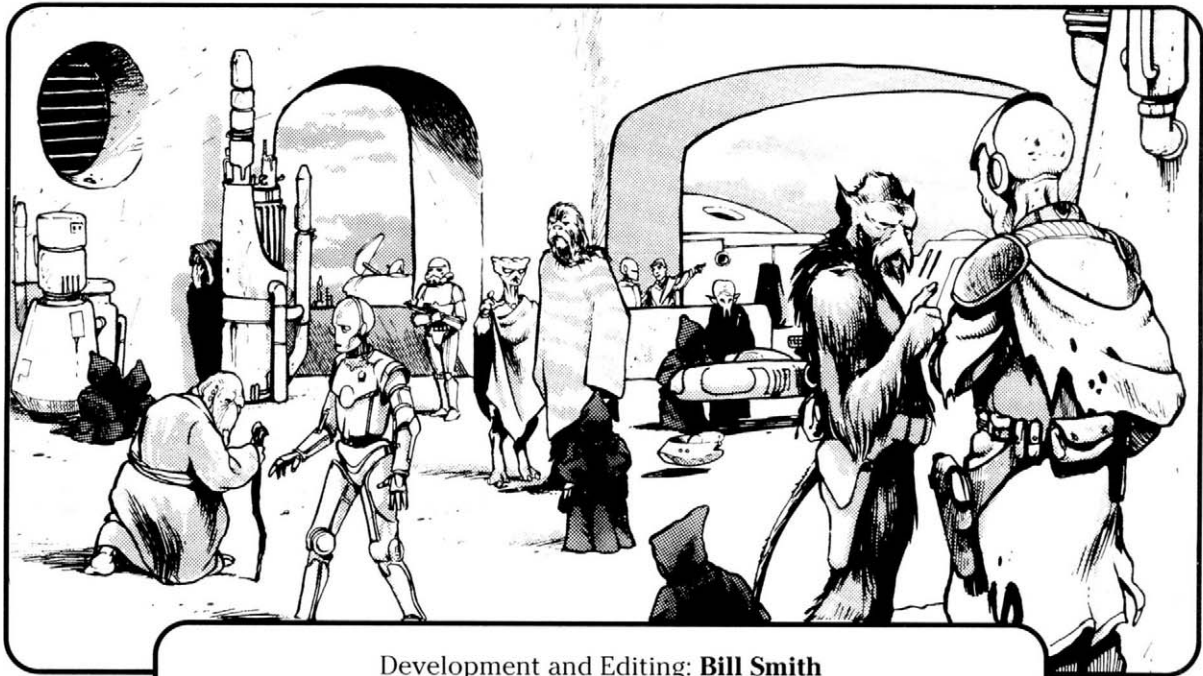

Development and Editing: **Bill Smith**
Graphics: **John Paul Lona** • Cover Art: **Lucasfilm Ltd.**
Interior Art: **John Paul Lona, Allen Nunis, Mike Vilardi**
Additional Illustrations: **Paul Jaquays, Mike Manley, Lucasfilm, Ltd.**

Publisher: **Daniel Scott Palter** • Associate Publisher/Treasurer: **Denise Palter**
Associate Publisher/Sales Manager: **Richard Hawran**
Editors: **Greg Farshtey, Bill Smith, Ed Stark** • Art Director: **Stephen Crane**
Graphic Artists: **Cathleen Hunter, John Paul Lona** • Sales Assistant: **Bill Olmesdahl**
Licensing Manager: **Ron Seiden** • Warehouse Manager: **Ed Hill**

Published by



RR 3 Box 2345
Honesdale PA 18431

40069

Introduction

“Mos Eisley Spaceport ... you will never find a more wretched hive of scum and villainy.”

Two figures saunter with a measured gait down a narrow, dusty alley: one is a Human, the other a Droid. The sandstone walls protect them from the terrible brightness of the twin suns but not the oppressive heat. A small cowed figure detaches herself from a doorway and approaches them.

There is some discussion as the woman shows the man a package concealed beneath her shabby cloak. The man fingers the bag of spice the woman offers, and then hands it to the Droid for examination with a sensor probe. The man is thumbing a money pouch around his waist when the Droid makes a disparaging comment.

The woman points a threatening finger at the Droid, and then at the man. The man lets go of both the spice and his money and shoves her. She replies with a blur of motion — a blaster pistol is suddenly in her hand and there are two flashes of green blaster fire. The man drops, then the Droid. She quickly finds the coin pouch and covers the bodies with debris. She strolls away unhurriedly.

The woman walks down the alley with confidence. It is a rich haul. And no one will ask questions about what has happened. She knows that she has mastered the ways of Mos Eisley in a way that few others will. Now, it is time for a brief celebration.

She fails to notice the three ruffians watching from one of the rooftops. They move in and drop a lasso. It lands expertly around her neck — they have done this before. She is soon forced to part with her ill-gotten gains and her last breath. The ruffians hurry away.

Meanwhile, a maintenance Droid on a break from work saunters past the two bodies. It stops upon hearing the damaged Droid's plea for help and bends over the helpless Droid, rummaging around. It grabs a pair of the Droid's servomotors, ripping them from the damaged Droid's legs. It then continues down the alley.

Beware!

Welcome to Mos Eisley! *Galaxy Guide 7: Mos Eisley* presents an in-depth look at this famous pirate spaceport. Known in many quarters as the home base of the infamous crime lord Jabba the Hutt, Mos Eisley is a dark and dangerous city with profits to be made and lives to be lost.

This traveler's guide offers you a glimpse into the people and places of the notorious spaceport, with illustrations, diagrams, maps and game statistics for use with *Star Wars: The Roleplaying Game, Second Edition*.

This book takes you to the back streets and docking bays of a pirate city famous for its dangers and opportunities. Characters come to life and the famous Mos Eisley Cantina and many other fantastic locations are now ready for your own *Star Wars* adventures.

This book contains detailed information on the city, but it is suggested that the gamemaster have *Tatooine Manhunt* for additional information, as well as a beautiful full-color map of the interior of the city. If gamemasters are looking for additional interesting characters to populate Mos Eisley, refer to *Galaxy Guide 1: A New Hope* and *Galaxy Guide 5: Return of the Jedi*.

Naturally, this guidebook is useful for running adventures in and about Mos Eisley. This book allows the characters to wander freely in this interesting location, while giving the gamemaster information on many new locations, breathing life into this city.

Additionally, most of the information in this book can easily be transported to other rough-and-tumble trade cities. For example, the personalities inhabiting the Mos Eisley cantina can be transported to another spacer bar halfway across the galaxy. Anywhere a sizable collection of beings congregate, aided by an ever-present underworld and a policy of free trade, you can find a place suitable for mayhem. Mos Eisley is but one of many such areas in the galaxy.

After skimming through this book, the poten-

tial for adventure should be obvious. The texture of Mos Eisley is rundown and derelict. There are transients in alleys and dark forms flittering to and fro down dark passageways. All five senses are assaulted.

The winding stairs, dark alleys, crumbling buildings and random mine shafts are great for running battles. A landspeeder chase, conversely, is likely to end quickly because skewed alleys narrow suddenly or turn abruptly.

A lack of police protection makes the often-messy consequences of a firefight nonexistent. This attitude is reflected in most of the inhabitants. As long as you do not damage their property or injure them, they are not likely to take much notice.

Characters can also get pulled into corporate espionage adventures — the key is to grab what is needed before the shooting starts. Characters can become involved in the massive organization of Jabba the Hutt, or simply run into the countless small-time hoods who inhabit the back alleys of the city.

The factory areas to the north of the city offer a slight change of scenery — the piping and caverns of the oil rig-like buildings and abandoned mining tunnels add suspense. Remember when the *Millennium Falcon* was going through the tunnel inside the second Death Star? The pipes and corridors created by the superstructure of the battle station was a terrific background for a high-speed chase. Keep the Death Star in mind when your smugglers careen through abandoned oil refinery platforms and closed Droid construction plants. The caverns are great for “bug hunts” or “hide and shoot” scenarios: the cavernous chambers and overhead spars create ominous shadows behind which might be lurking ... anything.

In short, Mos Eisley is a great setting for many different kinds of stories, all with danger, excitement and adventure unique to the *Star Wars* universe.

Slang of the Sands

Mos Eisley has its own terminology, just like any other city across the galaxy. Some of the more choice bits which visitors may stumble over are listed below.

Bantha Fodder: Worthless or waste. “You won’t be worth bantha fodder.”

Binary: As in, “You can be so binary at times.” Meant as a criticism, denoting extreme stubbornness, or inability to compromise on an issue.

Bloated One: Specifically Jabba the Hutt, but can be used as a disparaging reference to any Hutt.

Buy the Depp: To die, usually violently. Rather recent, named for the former Prefect. Probably started in the police force.

Feed the Sarlacc: To disappear, never to be seen again; to hide from legal authorities.

Final Jump: To die, usually peacefully. Origin is from the jump to lightspeed.

First Twilight: The time between the first and second sunsets.

Gravel Maggot: (Also “feed like a gravel maggot.”) A disparaging term for a person who takes advantage of others. Named after a native scavenger.

Grease the Servomotors: To bribe an official.

Jawa Trader: Anyone who isn’t honest, or trades in stolen or badly damaged goods. Other comparisons to Jawas often involve dishonesty as well.

Moisture Boy: Young moisture farmers who come to Mos Eisley wild-eyed and with no common sense. Refers to anyone who doesn’t know his or her way around. **Warning:** Using this phrase in farming communities is a good way to start a fight.

Lost in the Wastes: To be totally unprepared for a situation. Refers to getting lost in the Jundland Wastes.

Sand Mine: Something worthless. Something that anyone with common sense should know better than to get involved with.

Suns-scorched ball: Tatooine.

Tatoo: The Imperial Reference for Tatooine’s twin suns, Tatoo I and Tatoo II.

Tourist: A person unable to get anything done. Refers to Governor Tour Aryon’s inability to accomplish anything. Deliberately confusing to visitors.

Chapter One

Tatooine

"It was a vast, shining globe and it cast a light of lambent topaz into space — but it was not a sun. Thus, the planet had fooled travelers for a long time. Not until entering close orbit around it did its discoverers realize that this was a world in a binary system and not a third sun itself."

Like many other frontier planets plotted by the Republic Survey Corps during the heyday of the Old Republic's expansion, the first planet in the tri-planetary system J11.9 looked to be a promising source of minerals and other raw materials for a hungry galaxy. The initial (admittedly cursory) inspection turned up no intelligent indigenous life forms, and the planet was approved for colonization.

Settlers were plentiful back then. The Republic had been growing in leaps and bounds. But the Republic was unimaginably huge. Millions of habitable worlds had been catalogued by the time they discovered this little planet — it took time to settle them.

So it was no surprise that almost a thousand years passed before the first official Republic colony ships dotted the surface of the rugged planet. No matter what conditions might be like on the new world, the settlers were convinced that it was superior to what they had left behind.

First Contact

As is now known, there were indeed indigenous life forms. One species was encountered soon after the settlers arrived. Although instinctive cowards, these small beings seemed covetous of the Republic's technology.

Whatever their origin, these intelligent, rodent-like scavengers avoided direct contact with the settlers, and communicated in a language indecipherable to the new homesteaders. The leader of the new colony, Melnea Arnthout, suggested letting the enigmas be. There was an urgency evident in this request: one of the colony ships, the *Dowager Queen*, had crashed many kilometers away while on final approach, deny-

Tatooine

Type: Terrestrial
Temperature: Hot
Atmosphere: Type I (Breathable)
Hydrosphere: Dry
Gravity: Standard
Terrain: Desert
Length of Day: 23 Standard Hours
Length of Year: 304 Local Days
Sapient Species: Humans, Jawas(N), Tusken Raiders(N)
Starport: Standard Class
Population: 80,000 (Estimated. There has never been a census taken on Tatooine.)
Planet Function: Smuggling, trade, subsistence
Government: Imperial Governor
Tech Level: Space
Major Exports: Illegal munitions (smuggled), illegal security devices (smuggled), illegal drugs (smuggled), minerals (salt, sand-products)
Major Imports: Mid-technology, high-technology, metals, foodstuffs, chemicals
Points of Interest: Mos Eisley Spaceport, Jabba the Hutt's Palace

System Data

Region: Outer Rim Territories
Sector: Arkanis
Moff: Alexander Julstan IV
Governor: Tour Aryon
System Name: Tatoo
Star Name: Tatoo I, Tatoo II
Star Type: Yellow Binary

Orbital Bodies

Name	Type	Moons
Tatooine	Hot Terrestrial	1
Ohann	Gas Giant	3
Adriana	Gas Giant	4

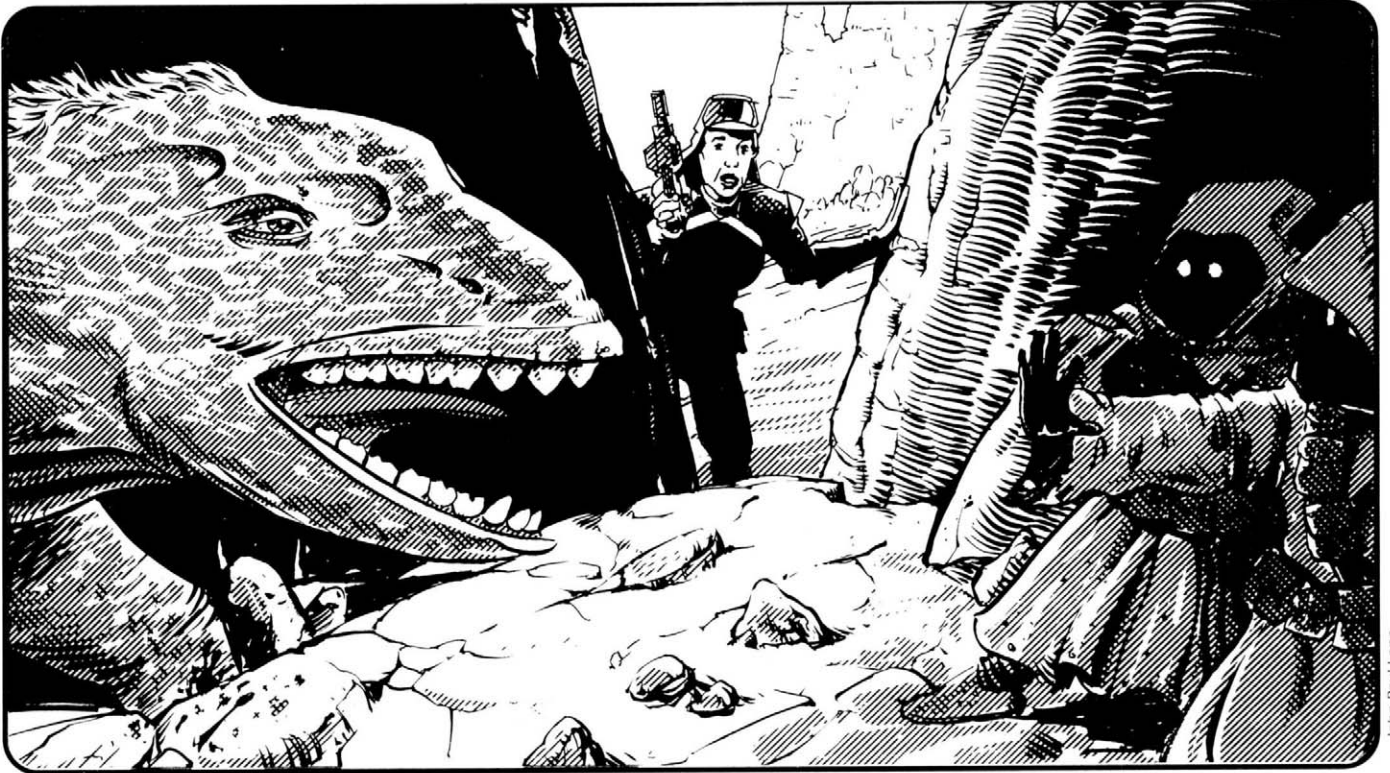

John Paul Lona

ing the remaining colonists extra supplies, leaving not even the slimmest margin for error. It was critical to finish getting the water, power, and food processors up and running. That first season was difficult: sandstorms nearly destroyed every building, most of the Banthas disappeared, and barely enough food was grown. The settlement, dubbed Bestine by the new homesteaders, barely survived that first precarious season.

The disappearance of Melnea's protocol Droid after just one season changed everything. The settlers were enraged; Melnea knew that she must act quickly — not only to assuage her group's fear and regain valuable property, but to prevent this from happening again. She needed to begin negotiations, but she was a settler and had little experience as a diplomat. Nevertheless, Melnea decided to make the attempt herself. She succeeded in opening a dialogue with the local group of Jawas who had taken her Droid.

With the aid of the Jawas, the Republic settlers adopted the Jawa term for the planet ("Tah-doo-Een-e"), learned the names of various land features and wildlife (such as the Dewback lizard that Melnea aided), and were warned about the second form of intelligent life on Tatooine that was somehow missed by the Republic Survey Corps: the Sand People.

The colonists expanded, founding Fort Tusken in the Jundland Wastes far to the north. Both Bestine and Fort Tusken got down to the serious

The Sand People

The origin of the Sand People is yet another area of great debate. Some scholars believe that it is likely these savage warriors evolved from a long-forgotten colonization attempt by an unknown species; others theorize that they simply evolved on the planet.

They are savage, but fearful, known to attack only when they have a clear numeric advantage. They seem to have a nearly symbiotic relationship with Banthas (it is unknown whether the Banthas were stolen from the colonists, or, as on many other worlds, they were present on Tatooine prior to colonization), and also utilize some technology, such as blasters stolen from their victims.

For now, their history and background is a mystery; perhaps someday, scientists will acquire a Tusken Raider for examination, but as of yet, none have been captured.

business of ore mining and learned the delicate art of coaxing moisture from the atmosphere for growing crops. However, the Sand People made their presence known. The first attack on Fort Tusken lacked the element of surprise, but still resulted in casualties.

Over the next several seasons the colonists sparred with the newly named Tusken Raiders. The settlers apparently were deemed to be too much trouble to tangle with, and the new residents determined that the population of the Sand People was too small to pose any real threat. The

Between A Rock And A Hard Place

Melnea set out into the hot desert at first twilight. As she walked into the darkening hills, she hoped she could win over the small creatures by approaching them alone and unarmed. Scrambling over a small hill, she paused. Despite the setting suns, the desert was still too hot. But she knew it would soon turn bitter cold. She checked the parka and tools stored in her backpack, swept her long black hair back behind her ears, and resumed her hiking.

Another hour's walk brought her scraped hands and knees, but no sign of the elusive residents. For all she knew, they were watching her from the dark regions of the canyons. Rounding a corner, she suddenly spotted a group of the tiny folk cornered against a rock outcropping. Facing them was what looked to be a huge reptile. It was whimpering in pain as its massive head lolled from side to side. Melnea saw immediately that the lizard's bleeding front paw was caught in a fissure of rock. She also saw that the beast was well within range of the little creatures, who could only huddle in fear.

She moved swiftly, throwing a rock behind the beast. The lizard turned away, toward the distraction, and she moved in closer. Grabbing a hydroshovel from her backpack, she wedged it in the crevice and yanked. There was no change, and the beast was turning back to her. She dodged a front paw plunked down blindly by the lizard as it attempted to twist free its foot.

Melnea grabbed a piton from her pack and, using the hydroshovel as a hammer, chipped away at the sides of the fissure. Her hair fell into her face. She could feel the warm air blowing from the beast's nostrils as she worked. She concentrated on chiseling away at the stone.

Then its head blocked out the final light of the second twilight as its jaws dipped toward her. She gave the hydroshovel one last pound, the rock splintered, and the lizard suddenly heaved itself free. It snorted once or twice, but made no move to attack. Instead, it lay down and licked its injury.

With that, the brown-clad natives grabbed a heavy cable and threw it over the beast's head. They jabbered to each other in that language Melnea and her friends had puzzled over for so long, and finally beckoned for her to follow. With her heart soaring, she walked behind them as they led her to a nearby area. It was a small village hidden among the cliffs and mountains of the area. A corral of sorts was set up, in which two other beasts like this one appeared to be grazing for moisture, pushing their noses deep into the desert gravel.

The creatures put the lizard in the stockade and disappeared into a cave. Melnea followed. Although it was dark out, the utter blackness of the cave required some adjustment. She paused, trying to listen. Surely these creatures weren't capable of seeing in the dark? Suddenly a metal arm grabbed her and a voice exclaimed, "Mistress Melnea! Oh, thank goodness!"

"Twopio? Is that you?"

"Thank heavens you've come! These Jawas ... these *creatures!* Oh, my. And not an oil bath anywhere to be found!"

Melnea grinned and relaxed. It was, indeed, 2PO. "Twopio, is that their name? Jawas?"

She could almost sense the Droid straightening himself up, in a move as close to a strut as was mechanically possible.

"Yes, Mistress. I have had ample opportunity to be immersed into their culture and have managed to decipher some of their language, complex as it is. They call themselves Jawas. And they, uh, borrowed me mostly out of curiosity, not malice."

Melnea patted 2PO's arm. She knew the high-strung Droid. When the Jawas first captured him, he probably thought he was about to be eaten or broken down for parts. She realized he had had terrific motivation to learn the language, for which she was very thankful. As she sat down, a stove deeper in the cave glowed to life. Melnea brushed the hair away from her face and saw Jawas scurry about preparing a meal. "Twopio, tell me more."

Raiders have since contented themselves with attacking a few colonists a year, and since the Human population claimed its share of Tusken, peace (of a sort) reigned.

A Growing World

With the Sand People situation under control, Melnea's full attention could now be turned to the mining of local ores. An evaporated sea bed east of Bestine, near the wreck of the *Dowager Queen*, was surveyed with promising results, and preparations for mining were begun in earnest.

The planet's terrain, while not "fertile," could

still support enough crops to provide sustenance for the small population, leading to the establishment of the small towns of Anchorhead and Motesta; Fort Tusken was abandoned due to the harsh conditions of the area.

The Republic miners established a new town on the sea bed itself, called Mos Eisley, around the site of the *Dowager Queen's* remains. Not far from the boundaries of the new town, a power and water distribution plant was built, and the town prospered, despite its rough-and-tumble nature.

Nuclear-powered steam vehicles dubbed *crawl-*

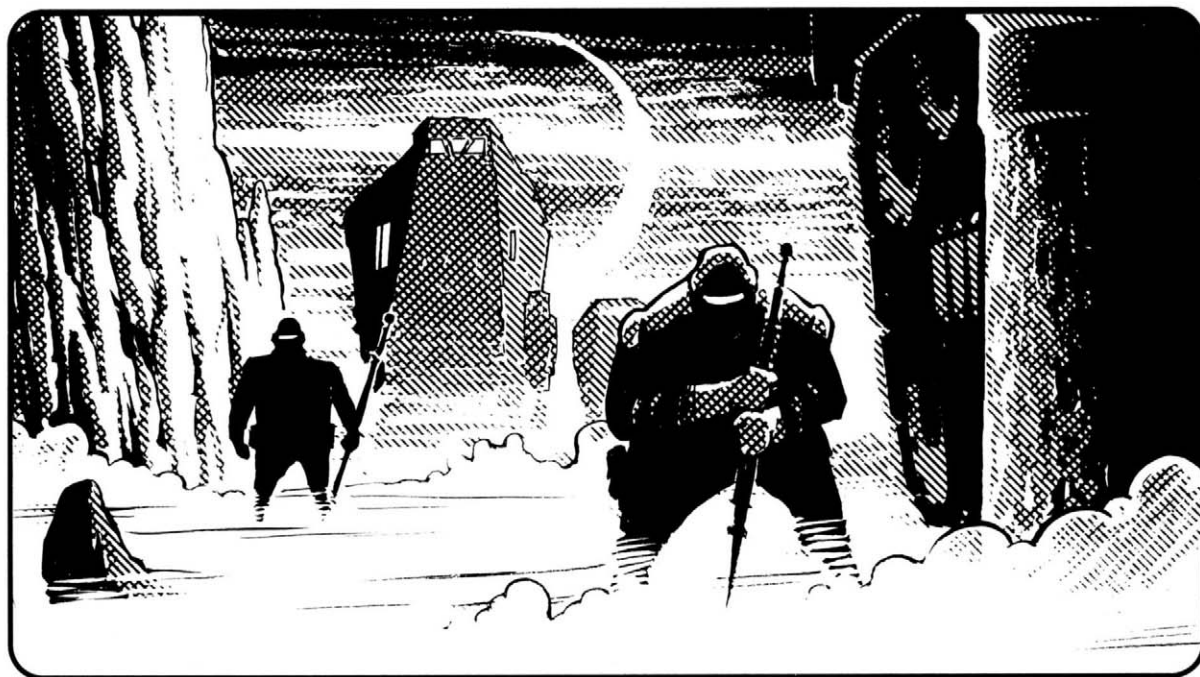

ers served as huge, mobile mining platforms. With the crawlers easing the excavation and smelting chores, Tatooine seemed well on its way to economic success. Mos Eisley grew in leaps and bounds, serving as the major spaceport in addition to the center of mining.

However, the colonists soon learned of another great danger of this desert world. It was learned that the huge sandstorms completely blinded starship sensors. Casting sand many kilometers into the air, with storm fronts sometimes hundreds of kilometers long, a sandstorm could effectively cut off all settlements from contact for weeks. Ship sensors couldn't tell where the storm ended and the planet began, resulting in several crashes in a very short period of time. Worse, the storms could come up in a matter of minutes, giving almost no notice to the towns that lie in the path of these engines of destruction.

Then, another disaster struck. *Tatoo III*, the brand new orbital station — designed to transfer cargo to and from those transports not capable of atmospheric flight — was destroyed. The first impulse was to blame the ship *Obvious Nirvana*, which was approaching for refueling at the time the disaster occurred. But the survivors who escaped in its lifeboat stuck to their story that, as the ship approached the station, there was an irresistible pull. The flight recorder verified that the ship's engines were in full reverse. There was no immediate explanation for the disaster.

In the final analysis, the culprit proved to be the metal used in the construction of the station, the majority of which had been manufactured on Tatooine. The ore, after refinement, seemed to

randomly assume the properties of a magnet.

Experiments were hurriedly performed, and it was found that this reaction was linked to the cycles of the twin suns; the means to fix the ore was determined, but it was prohibitively expensive. Competing sources could charge one-fifth the final price that the miners would have to impose.

Tatooine's heyday was over. The mining corporation went bankrupt, and in a few short seasons the mines were all but abandoned. Although some miners left Tatooine, most of the support services, moisture farms, and most of the colonists themselves, remained.

The majority of mining equipment was sold off (or, in the case of the crawlers, abandoned and then reclaimed by the Jawas), and Mos Eisley eventually grew over the top of the excavations.

Life After The Mines

"If there's a bright center to the universe, you're on the planet that it's farthest from."

To say that Tatooine is far from the galactic mainstream is an understatement bordering on the ludicrous. While Tatooine is easy to get to, there are very few reasons to actually go there.

As the mining industry collapsed, so did Tatooine's economy. Subsistence farming fed the population, and the sand provided some small revenue, but for the most part, the planet's trade was minimal. So far removed from the happenings of the galaxy was Tatooine that the passage from Republic to Empire was but a change of name to the local moisture farmers.



Alien Nunis

ALIEN
NUNIS
'72'

The End of an Era

Prefect Orun Depp was toying with his breakfast when the officer appeared. He pushed around the contents of his plate, upon which was resting the remainder of his one thousand one hundred and thirty-eighth breakfast of poached Krayt egg and leg of Sandhawk. He welcomed the interruption. "Yes?"

Lieutenant Harburik controlled his impulse to sneer. "ComScan reports that a Star Destroyer and a small Corvette dropped out of hyperspace half an hour ago. There was some exchange of laser fire. Governor Aryn has asked you to handle the matter."

The Prefect stood, hurriedly swallowing the remaining bits of Krayt egg. "Well, now, that is news. Well, well. It's a good thing I — they'll have to parlay with me for the right to refuel, or whatever, right? Lieutenant, how much room is available in our jail?"

Harburik sighed. "Sir, we have the Tonnika sisters; a Human was arrested for impersonating an Imperial officer; a Gamorrean is charged with beating a civilian; and a Rodian was caught pickpocketing."

"Hmm. Better release the twins. I want to have enough room for —"

"Sir, the twins are by far the worst offenders of the lot!"

"Lieutenant. An Imperial Star Destroyer. *Here*. At Tatooine. Why, the implications of that are staggering. Well, now ..."

Harburik smiled to himself in anticipation of the reaction his next bit of news would have. "And, sir, they have just informed us they are sending down a detachment of stormtroopers."

The Prefect stared at Harburik as if he had three heads, and then began spinning around the room, bumping into everything. Harburik had the vague urge to grab the man as if he were a spinning top.

"*Informed* us? Not *requested*? What is the meaning of this? There are proper channels which must be followed, after all. Don't you agree, lieutenant? We

will see about this." Depp broke off and strode out of the room.

"Well, err, yes. Yes, sir," he repeated again for emphasis, inwardly gloating over the Prefect's discomfort as he followed the man through the building and into the control center.

"Let *me* talk to that captain. How dare he think he can simply send down troops without authorization."

Harburik excused the communications officer and sat at the console himself, signaling the Destroyer. Depp furiously paced the small room as the lieutenant tapped a few last controls and gestured over to the hologram pod. "Here you are, sir."

Depp stepped onto it, and as his image was being captured and transmitted to the Destroyer, a corresponding hologram formed in front of him.

"Now, just what is the meaning of this?" Depp began, but cut himself short as a chill swept through the chamber. "Why, err..."

The raven figure flickered. "I have no time for pleasantries, Prefect. I have ordered a detachment of troops down to Mos Eisley on official business —"

Depp clutched at every last wisp of fleeing outrage and swallowed hard. "Yes, but the proper channels need to be followed, uh, Lord Vader." He felt his resolve weakening. "Even one such as yourself, ur, understands the need for discipline in the ranks." His resolve wavered for a moment, then collapsed. "Isn't that right?"

The holo image continued as if it had never been interrupted. "— by order of the Emperor. Expect two more Star Destroyers which shall constitute a quarantine of Tatooine. Effective immediately. Is that clear, Prefect?"

"This, this is highly irregular ... but as you wish, Lord Vader." The image faded, and Prefect Depp turned to Harburik, pulling on his collar. "Make appropriate accommodations for the soldiers, lieutenant. I want them to be served in every way possible."

However, Tatooine has in many ways recovered, but not through respectable industry. An up-and-coming crime lord known as Jabba the Hutt selected Tatooine to be the base of his organization.

Jabba's reasons for choosing Tatooine are clear. First, Tatooine is close to a major trade route, yet it is a world that is easily ignored. From Tatooine, it is easy to reach Alderaan and several minor trade worlds; from there, Imperial System (Coruscant), the Corellian System, and other major systems are easily accessible. On the other hand, there is no reason to venture to Tatooine — only a bunch of poor sand farmers. Jabba could be close to the action, yet remain virtually unnoticed.

Second, Jabba was able to secure some means of security. No one knows how or why, but Jabba was able to bribe or frighten the old Imperial Moff into ignoring his activities. Over the years, new Moffs have come and gone, but all have been subservient to the crime lord for reasons unknown.

As a result, Tatooine is technically under the domain of the Empire. However, it has had a string of ineffective and apathetic governors. The desert world has become a center of smuggling and criminal activities, with the galaxy at large unaware. In short, Tatooine is a world that no one notices or cares about.

Tatooine still lacks a unified central govern-



Mike Vilardi

ment: there is so much unclaimed territory that one is unnecessary. Representatives of each township meet as necessary to discuss matters of trade and mutual defense. The Imperial governor issues decrees only as necessary to maintain the peace and collect taxes. As residents are fond of saying, "Tatooine isn't *worth* fighting over; it's a big hunk of nothing."

The Economics of Sand

Tatooine's economic picture seems universally gloomy, at least in an analysis of *official* businesses. Tatooine is incapable of sustaining itself using planetary resources, with a trade imbalance that has yet to be adequately addressed, at least officially.

Moisture Farming

First, the moisture farmers are the very backbone of the planet's economy. Moisture farms cover almost ten percent of the planet's surface: an incredible amount of land. It is a risky business and most farmers are barely getting by season after season. A few have managed to parlay their profits into larger and larger farms, but the vast majority continue to border on poverty. Water is one of Tatooine's most precious commodities. In addition to its value for drinking and other essential uses, the harvested water is pumped into huge subterranean produce gardens.

Processed Sands

The sand offers a creative being a means to live. Processed sodium sand is used in several polymers and glues common in industrial construction. However, Tatooine faces competition from many other sodium sand-rich worlds, not to mention a dozen other substitutes. Therefore, the market value is always in flux — a shipment might only be worth half its original value once it reaches its destination.

Tatooine Sand Castings

Third, sand is used to create Tatooine sand castings. Always on the lookout for the unique, the upper stratum of Imperial society discovered the value of this handcrafted art as unique conversation pieces. Unfortunately, the demand for this fad, now five years old, appears to be leveling off.

The Crime Lord

Jabba the Hutt's criminal syndicate appears on no Imperial economic analysis, yet its mere presence sustains the entire planet's economy. The Hutt indirectly employs a good percentage of Mos Eisley's residents, and the government turns a blind eye to most of the Bloated One's revenue-producing exploits.

The underworld itself traffics mostly in information, with smuggling illegal goods and information *about* smuggling illegal goods (both theirs and others' operations), a close second. Mos Eisley's need to import most of its manufactured goods decreases official interest in the exact nature of a cargo. The situation encourages low-cost bribery and extortion as a way to move products smoothly. For whatever reason, the Imperial Moff of the sector has always made sure that Jabba can conduct his business undisturbed.

Imperial Government

The standard Imperial method of extracting subservience from client planets consists not so much of invasion as subversion. A token presence is deposited, with the authority to shape

Governor Tour Aryon

Template Type: Imperial Governor
Loyalty: To the Empire
Height: 1.6 meters **Species:** Human
Sex: Female **Homeworld:** Treydon II
Age: 37
DEXTERITY 2D+1
 Blaster 4D+1, dodge 4D+2, melee combat 4D, melee combat (vibroblades) 5D+1, melee parry 4D+2
KNOWLEDGE 2D+1
 Alien species 4D, bureaucracy 5D+2, cultures 4D+2, planetary systems: Tatooine 5D, streetwise 3D+2
MECHANICAL 1D
 Beast riding 4D+1
PERCEPTION 3D
 Bargain 6D+1, command 7D, con 5D, gambling 5D+1, persuasion 5D+2
STRENGTH 2D
TECHNICAL 1D+1
Special Abilities: None
Force Sensitive?: No
Force Points: 0
Dark Side Points: 0
Character Points: 11
Move: 9

Description: A finely-featured woman with an ebony complexion, sporting the latest fashions. She is slight of build, yet exhibits an imposing presence.

Background: Tour's contributions to Tatooine have been mainly cultural: Bestine has the only museum on the planet, with a complete Krayt Dragon skeleton. Her lavish parties and expensive imported entertainment have kept her busy, although her efforts have been lost on the moisture farmers and mechanics. She has little respect for the residents of Mos Eisley and considers them peasants and savages.

Personality: Tour is sharp and quick-witted. She can size up a situation in moments, and react accordingly. She often assumes an air of a general inspecting her troops.

Objectives: Keep Tatooine quiet, and thus secure an eventual promotion (and relocation).

Quote: "Sigh. I will not postpone my garden party simply because Talmont cannot deal with a small insurrection. I will handle it tomorrow."



Kant Aryon

Template Type: Retired Con Man
Loyalty: To his wife
Height: 1.7 meters **Species:** Human
Sex: Male **Homeworld:** Bethars
Age: 32
DEXTERITY 3D+1
 Blaster 5D+1, brawling parry 4D, dodge 6D+2
KNOWLEDGE 3D
 Cultures 4D, languages 4D, streetwise 6D+2
MECHANICAL 3D
 Astrogation 4D+1, beast riding 3D+1, repulsorlift operation 4D
PERCEPTION 3D+1
 Bargain 4D, con 5D+1, gambling 6D+2
STRENGTH 2D+1
 Brawling 4D+2
TECHNICAL 3D
 Computer programming/repair 5D, Droid programming 4D+1, security 4D
Force Sensitive?: Yes
Force Points: 3
Dark Side Points: 2
Character Points: 10
Move: 10

Description: A robust man of medium height and ebony complexion, dressed in the latest Imperial fashions. He looks like he used to smile a great deal.

Background: The son of a baron and baroness, Kant grew up in the lap of luxury. He has concocted many elaborate swindles and soon learned that a great deal of money was available for the asking if he played along. He has served as an agent for the gangster underworld for many years.

His love of con games is matched only by his love for Tour. They met eight years ago and were soon married. It was blind luck that landed the two here on Tatooine, so near Jabba the Hutt.

Personality: Kant is no longer the happy-go-lucky gambler. He is aware that his career could jeopardize the only thing in his life he truly cares about: Tour. This has turned him into a recluse, and a somewhat jumpy, nervous fellow.

Objectives: To keep separate his underworld business and his personal life.

Quote: "I quite agree that the prefect can handle the disturbance, my dear. Here, let me prepare a whirlpool bath of Krayt egg salts."

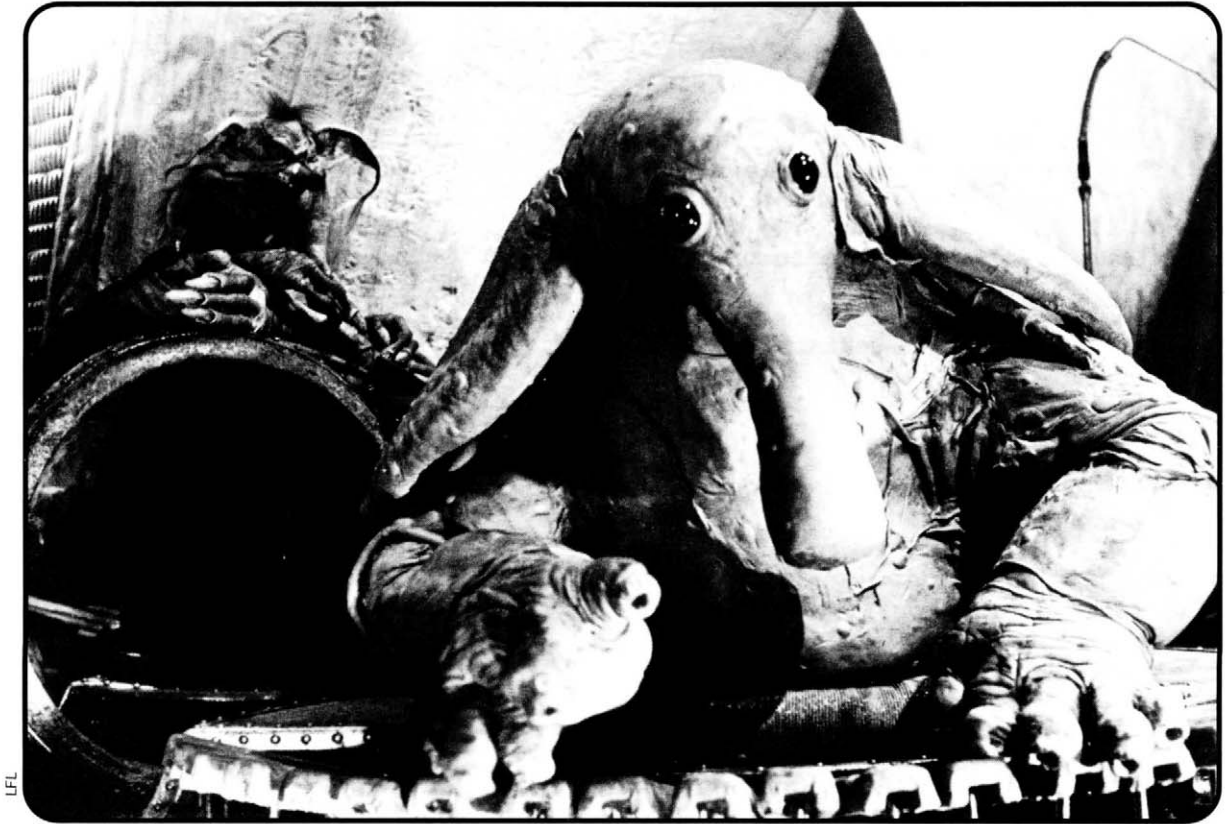

LFL

and mold law; the threat of an Imperial crack-down is enough to elicit obedience. From this position of strength, the local customs and rules are often modified to better fit the Imperial penal and revenue codes.

On Tatooine, this procedure fitted the needs of the Empire perfectly. Moff Julstan's appointments have tended toward generating tax revenue and ignoring smuggling. To the average resident of Tatooine, the Empire was a long way away.

The current governor of Tatooine, Tour Aryon, has taken even less of a hand in the daily affairs of her people. When first appointed, she moved her offices to an almost palatial house in Bestine, and appointed Orun Depp her Imperial Prefect, and charged him with running the day to day affairs of Tatooine.

Aryon and Depp were under great pressure when the Empire turned its sights to the distant world in pursuit of two escaped Rebel Droids, but as the Imperial Fleet retreated, so things have gone back to normal. More stormtroopers have been garrisoned on the world, but they don't answer directly to the government, providing a convenient time lag for those, like Jabba, who benefit from unorganized military efforts. As a result, the extra troops are still unable to stifle smuggling — perhaps the desired result of someone higher up in the Imperial chain of command.

After Depp's rather unfortunate demise, Aryon

appointed Eugene Talmont as her new Prefect, advising him to keep a lower profile than his predecessor.

How The Government Affects The Average Person

As said before, to the average person who lives on Tatooine, the Empire is a very long way away. Unless one happens to be in the wrong place at the wrong time, the Empire's military forces are seldom encountered, and people don't see much of the militia or the police either. People, especially in the isolated farming communities, are expected to take care of themselves. Because virtually everyone has some kind of weapon and homesteads are so scattered, there is a great amount of respect between neighbors — few people will ever rely on the courts when simple negotiation can solve most disputes.

There are moderate sales, income and property taxes that everyone complains about but no one seems inclined to actually protest. Townships are self-governing, doing what they will with their own tax revenues — often little more than buying a few spare power generators or repairing something that was destroyed in one of the massive sandstorms. Each town also issues its own IDs to all citizens, although they all contain the same information: name, age, nearest relatives, occupation and address.

Tatooine's Geography

The course of the characters' adventures may take them to some of the distant townships and locations of Tatooine. Some of the most likely destinations are described below.

Anchorhead: Several hundred kilometers southwest of Mos Eisley, this farming hamlet has a population of only 700. The town itself only has a small cluster of buildings, including a transport station, a restaurant and other elementary services, but it serves a large community of moisture farmers. It is effectively cut off from Mos Eisley by the the Jundland Wastes. It is linked to Mos Eisley by regular transport service.

Arnthout: A small farming community south of Bestine, with a population of about 350.

Bestine: The official capital of Tatooine, Bestine is a small town about 200 kilometers to the west of Mos Eisley. Home to about one thousand permanent residents, Bestine has the only museum on Tatooine and little else.

Dune Sea: A vast desert expanse, stretching for thousands of kilometers, known for unbearably hot days and frigid nights. The Western Dune Sea borders on the Jundland Wastes.

Fort Tusken: An abandoned settlement far along the northern reaches of the Jundland Wastes. It was

the site of the first conflict between Human settlers and the Sand People, or Tusken Raiders.

Great Pit of Carkoon: A huge pit in the heart of the Dune Sea, home to the infamous Sarlacc monster.

Jabba the Hutt's Palace: Located thousands of kilometers from Mos Eisley, in a small range of hills within the Dune Sea, the Palace is where the infamous gangster holds court. Isolated from civilization, people seldom arrive at the palace unless they are wanted by Jabba.

Jundland Wastes: A rough, dry canyon, mountain and mesa area, known to be nearly impassible except for the narrow Arnthout Pass. Known to be populated by Tusken Raiders, Krayt Dragons and many other dangerous creatures. The area runs along the Western Dune Sea, with a major branch cutting off Anchorhead and Mos Eisley.

Mos Eisley: The center of civilization on Tatooine, Mos Eisley is a major spaceport and is a prominent base for smugglers and criminals.

Motesta: A small farming hamlet in Arnthout Pass.

Tosche Station: A power, water and refueling depot about three kilometers due south of Anchorhead. The Tosche family is well respected by farmers in the Anchorhead region.

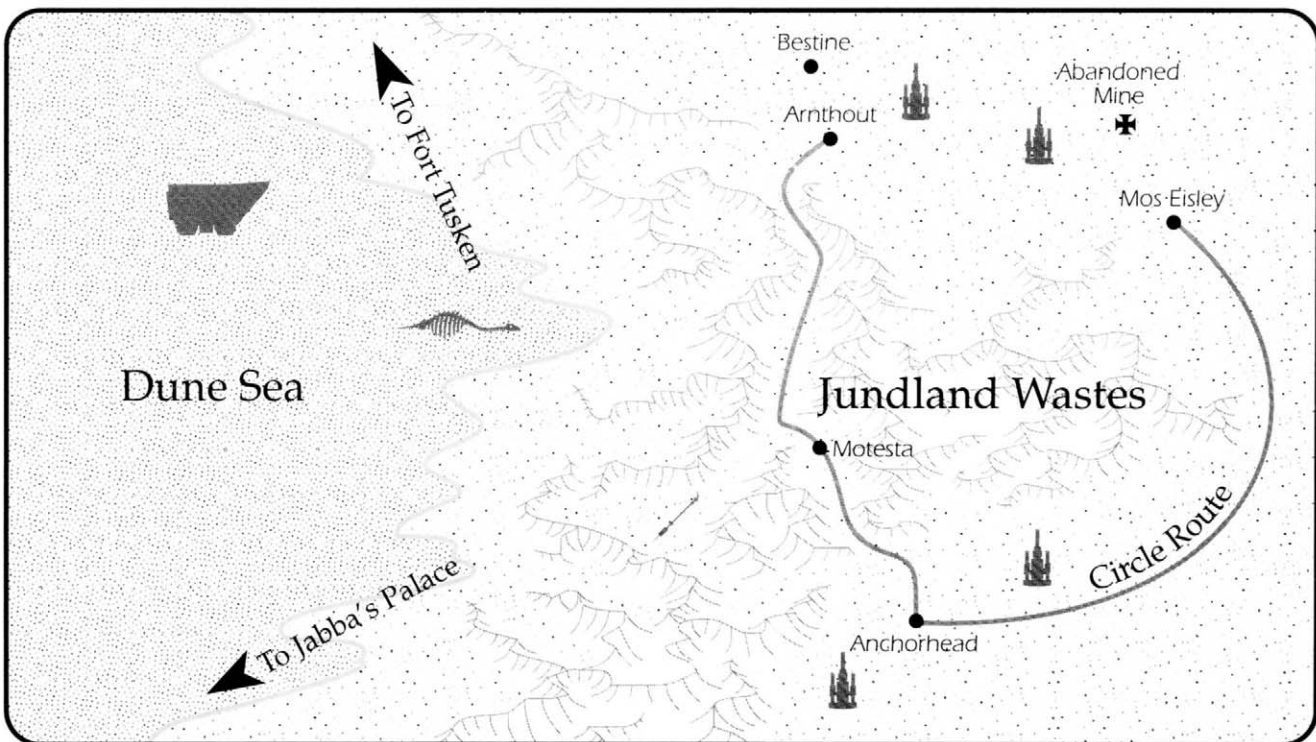

John Paul Lona

Chapter Two

Mos Eisley Overview

Mos Eisley is the only major civilized area on the vast desert planet of Tatooine, yet it is a dangerous, dirty and uncivilized port city, at least compared to the sprawling centers of trade in the Core Worlds. The pirate city offers much to the daring and enterprising, but the meek should definitely stay in the farm towns.

The average population of Mos Eisley is about 50,000-60,000 beings. This estimate increases when the local harvests come in, decreases when the economy of the sector sags, and increases (slightly) with tourism during Tatooine's "cool" season. Most transients live in Mos Eisley since there is little else on the planet.

The mix of species here is reminiscent of the Old Republic — a time when each species' individual viewpoint and contributions were prized

instead of belittled. Of course, the fact that there are potential fortunes to be made encourages people to be a little bit more accepting as well.

Getting In ...

Approaching Mos Eisley from space, the city is unremarkable. Situated in a sprawling valley to the north of the Jundland Wastes, the city literally simmers with the constant heat of the twin suns and the motion of its many inhabitants.

For a complete overview of the standard landing procedure, see location 23, "Spaceport Control Tower." In general, unless a ship's pilot makes a stupid statement (such as "We're smugglers," or "We're here on business from the Rebellion."), most ships are ushered into the city without any





Mike Vilardi

serious scrutiny. If a ship is identified as being in the employ of one of the local corporations the ship is virtually guaranteed to be allowed to land without hesitation.

Customs

Ostensibly, the customs office is supposed to prevent the smuggling of illegal goods and guarantee that all products are properly taxed. In practice, customs officials spend more time collecting bribes than confiscating goods.

Corporate docking bays are not subject to customs inspections in Mos Eisley. Instead, the companies each submit a seasonal list of incoming freight, upon which they pay two percent duties. This system is rife with deceit, but the city administration is understaffed and uncaring.

Using a privately-owned docking bay means a ship may be visited by a customs inspector, although the process has evolved into a tradition of nearsightedness. Free traders who visit the spaceport are required to fill out a cargo manifest and transmit it to the docking bay's owners, who then have a week to file it with the spaceport control tower. Regulars have become adept at creative writing, offering such diverting prose as "socio-economic technical adjusters" when describing a shipment of blasters.

Physical inspections of incoming cargo are infrequent. If a ship does manage to get inspected (only about one in 500 ships are so honored), the inspector usually expects 100 credits or so to

overlook any minor infractions; unless a smuggler is on Jabba's payroll, bribes for serious crimes, like spice smuggling or gun running, can be much higher. The inspectors don't expect an elaborate ruse, high-quality roleplaying or a song and dance to convince them that the smugglers are honest, happy-go-lucky tourists; they simply want their credits and they will go away.

Attempting to coerce or intimidate a customs official is a bad thing, and is one of the few things in this city that will summon police officers or stormtroopers, normally within a few minutes. The officials wear headset comlinks hard-coded to the spaceport control tower and police headquarters. Customs officials in Mos Eisley are out for themselves. If Jabba wants a particular ship impounded, and he is willing to pay a thousand or so credits for the privilege, no one at customs will refuse him. Of course, if someone blows a whistle on one of the Hutt's shipments, Jabba can easily buy the officials' ignorance.

Customs Inspector: Putten Beatus

Species: Near-Human

Sex: Female

Age: 29

DEXTERITY 2D

Dodge 3D

KNOWLEDGE 1D+1

Alien species 3D, bureaucracy 5D, languages 4D+2, law enforcement 5D+1, streetwise 2D+2, value 2D

Finding Work

"Is it watching us?"

"What? Is *what* watching us?"

"That Jawa over there — don't turn! Looks like it's got a comlink. It may be the same one who has been following us since we landed here this morning." Vareth's brows furrowed in concentration over her fozbeer. It was bad enough that they had forged ship credentials, but they lacked time or money to even try and get their own ID's changed. And they certainly had no legitimate business in this city. Now she wished she hadn't let Garron talk her into this. Pull a job for a gangster like the Hutt? She almost shuddered. But it was the only way to turn a quick credit. And it wasn't like they were preparing to engage in robbery or theft. Not really.

She glanced at her companion. At least Garron looked pretty calm. But it was difficult to tell with a Sullustan.

"How is it I am to tell you if he is watching or not, shall I?" asked Garron.

"Sigh. I don't know. I guess you can't. I wish we had an electronic scanner, or some kind of Droid eavesdropper. Or maybe —"

Garron cut her off. "Yawn."

"Pardon me?" asked Vareth, watching the Jawa out of the corner of her eye.

"Yawn, yes. Trust me."

Garron smiled. That was their personal signal, and their private joke. No one should ever trust a smuggler. "Okay."

Vareth did what she hoped was a good imitation of a yawn. She saw Garron's own jaw muscles clench until he finally succumbed to the overwhelming urge. And as she watched, the suspected spy turned away and put its hand to its mouth. Vareth grinned and momentarily considered the universality of the yawn reflex.

"Good idea, Garron. Let's go." The two stood and swiftly left the cantina. Their exit was noted.

The glare of the suns on the sand made Vareth want to turn back to the dim coolness of the bar. She glanced at Garron, who had already placed goggles over his sensitive eyes.

"How do we find his place? This whole area is a maze. We went in to get directions, but nobody seemed to know."

"Perhaps perchance it is not we who need to find them; the other ones must find us?"

"Yeah, maybe. Let's keep moving, though. I don't want to give anybody time to get a bead on us." Vareth put her scarf up to her nose as they passed a group of

Jawas. At least she had learned this much about Tatooine.

"Excuse me," spoke a metallic voice. Vareth froze. It sounded like a stormtrooper. She turned slowly around. She blinked once, then twice. There was no one there.

"Excuse me," the voice said again, from somewhere near her waist. Vareth looked down to see the Jawa holding a hand translator to its throat. "I have greetings from your employer. Please follow me."

"See what I have been telling is true now, yes?"

"Shut up, Garron." They followed the brown-cloaked figure as it weaved through the crowds, avoided a speeding landspeeder, and ducked into a dim doorway. Vareth easily kept stride with the creature as it sped down the cool dark tunnel, past passageways and side tunnels, first taking a left, then a right, skipping several doors, turning another corner, and finally stopping at a closed door. It muttered something Vareth was sure would have been incomprehensible even if she had heard it clearly. The door slid open with a scraping sound of steel against sand.

The room was dimly lit by a portable generator sitting on the floor. The earthy smell invading her nostrils was produced by the enormous number of mushrooms and other fungi covering the floor and walls. The only furniture in the room was a chair occupied by a pasty-looking Twi'lek, his head tails draped around his shoulders. The Twi'lek swallowed the last of his mushroom and licked his fingers. Vareth heard Garron enter the room behind her, and the door shut. This Twi'lek was egotistical indeed, to feel safe against two free-traders. Then again, Vareth reminded herself, they were here at his disposal to gain employment. Still, showing any fear would likely not get them the job.

"Yes," the sitting being said, his left head tail twitching, "you have been watched since you entered the system. And if you were to injure me, it is unlikely you could find your way back out of this maze."

Vareth straightened up to her full height. "Of course. Except my friend here," she stepped to the left to let the Twi'lek get a good view of Garron, "is a Sullustan. When it comes to tunnels they have a photographic memory. Shall we try this again?" She stepped forward. "My name is Vareth."

"Greetings, sly one. I am Bib Fortuna." He paused for a moment to let the announcement sink in, as if it were some great pronouncement. Because of the way the Twi'lek carried himself, Vareth had an itching notion to kneel, but ignored it. Fortuna cleared his throat. "You appear adequate to the task."

MECHANICAL 2D

Repulsorlift operation 4D+2

PERCEPTION 2D

Bargain 6D+1, con 5D, gambling 4D, search 6D+1

STRENGTH 2D+1

TECHNICAL 1D

Security 3D, space transports repair 4D+1

Force Sensitive?: No

Force Points: 0

Dark Side Points: 0

Character Points: 6

Equipment: Headset comlink, blaster pistol (4D damage), datapad

Description: A pale near-Human of indeterminate heritage, Putten's gray skin and large ears have attracted quite a few stares over the years.

Background: Putten has always been an outcast. Eventually, she wound up in Mos Eisley, and decided to take up residence and find a job here.

Personality: Gruff, demanding and abrasive. She does have a few close friends; everyone else is greeted with boundless hostility.

Objectives: To be obnoxious and demanding up to the very limit of her target's patience.

A Quote: "Sure you're a tourist — you're not fooling me, so give me *another* 50 credits. Hurry up so I can get out of here."

Other Options

Those who are overly-sensitive about the prospect of being searched can always try a desert landing. While this normally isn't too hard, it isn't very safe either. There is a very good chance that a ship out in the desert will get attacked by Tusken Raiders, torn apart by Krayt Dragons, dismantled by Jawas or simply blown away by the sudden and devastating sandstorms. There are a few private estates outside the city proper that might offer landing space.

Entering Mos Eisley on foot or by vehicle is nothing unusual — this is how most moisture farmers and Jawas reach the area. There are daily transports to other towns on the planet, such as Bestine, Motesta, or Anchorhead (with its famous "circle-route" around the Jundland Wastes which has been romanticized in popular songs). Trips from other towns on or near the Dune Sea require chartering a transport.

... Getting Out

It is always easier to get onto Tatooine than to leave. Pilots with legal documentation and unremarkable cargoes should have no trouble. The typical Mos Eisley freighter, however, has neither. Freighters and scouts who arrive empty and prepare to leave apparently still empty are



Mike Vilardi

expected to grease the servomotors before departure to prevent a sudden search. Delay also holds the captain liable for rental of the docking bay for as long as the ship is forced to remain.

It is possible to simply leave without authorization. The reaction in such cases depends upon circumstances — if the bay is company-owned, it is likely to take a dim view of such hasty good-byes. This unhappiness often manifests itself in the manner of dispatching corporate starfighters, in hopes of persuading the offender to return and say a proper good-bye.

Privately owned docking bays rarely have such options available. Instead, all information about the offender is transmitted to the authorities. On the off chance an Imperial cruiser is in orbit, has the time, and the captain is cooperative, the delinquent vessel might find itself outmatched. On rare occasions traffic control's antique cloud

First Impressions

The speeder inched its way slowly along the crooked streets. Dozens of disreputable-looking beings meandered through the maze, oblivious to the shiny speeder with the Imperial emblem. The place was hot, the buildings huddled close to the ground. Every so often a narrow alley offered shadows strung along its length, but the twin suns made sure that the shadows provided no relief from the heat. Or the smell.

"It's not much to look at, is it?" sighed Prefect Eugene Talmont, tugging open the collar of his uniform.

Lieutenant Harburik looked up from the instrument panel. "No, sir." The soldier quickly weaved around a cluster of Jawas. The brown-cloaked creatures scuttled alongside the speeder for a few meters, stroking the hood and jabbering at each other. The Prefect noticed a few flies buzzing about the hoods of the short creatures and instinctively recoiled. He turned around to watch them as the speeder eventually outpaced them and the small beings receded into the distance.

"Hmph. If this is the greatest settlement on the planet, I'd say that my stationing here will be a waste of my considerable talent. You'd think old Moff Julstan could find someplace more deserving of my skills as a negotiator: my learned finesse."

"Yes, sir. It's true that nothing much happens here." Harburik had met the man only five minutes ago and already detested him. He decided to let the Prefect find out for himself just how much activity was seething under the surface of this docile-looking city. Perhaps that would learn some of the smugness out of him.

"By the way, what do you know about why the old Prefect was removed from his post? I had heard of his general incompetence and idiosyncrasies — imagine wasting Imperial revenue on producing thousands of local maps to hand out free to visitors — but losing general incompetence onto this backwater planet seems harmless enough."

"Prefect Depp was killed in the line of action, sir."

"On this planet?" Prefect Talmont shifted uncomfortably in his seat. "Surely not a local uprising?"

"The report was a little vague, sir," Harburik said, in his most infuriating drawl, enjoying the Prefect's discomfort. "Something about an assassin Droid, as I recall."

"Oh. Oh ... my." Talmont blanched and sat back. "Shall we put the canopy roof up? Yes, the canopy, I think. We had better review the current police deployment once we reach my office. Oh, my."

The lieutenant smiled as he directed the speeder toward the Prefect's new office.

car tugs are dispatched (it is even rarer for them to succeed in waylaying a ship). Most often the complaint is simply filed, and passed on to all databases controlling access to bays on the planet.

Should Tatooine be placed under quarantine

(such a thing has happened only once in modern history), the presence of Imperial Dreadnaught Cruisers (or larger ships) should dissuade any but the most foolhardy or courageous from attempting to run a blockade.

Launching from outside a civilized area — the middle of the Jundland Wastes, for example — is usually performed without incident ... as long as the ship has not been buried by sandstorms or dismantled by Jawas by the time you return to it.

The City

From a distance, much of Mos Eisley blends into the desert. Sand-colored mounds disappear among the wavy currents of heat rising from the sunbaked land. Closer inspection, however, begins to reveal definition and purpose. Low grade concrete, stone and plastoid mounds spread out from power and water distribution plants like disease on a Gundark's wing. As form follows function, these buildings have curves and domed roofs to support the weight of the sand and to passively minimize dune buildup. Resistance to sandstorms is greatly improved by a subterranean emphasis. The domes also help reduce the size of mysterious mists which rise regularly from the ground at the points where desert sands wash up against unyielding cliffs and mesas, encumbering travelers with obscuring fog.

Although traditional Mos Eisley construction is underground, with perhaps one or two stories poking their heads out of the sand into the intense heat of the suns, some of the newer buildings, mostly commercial, are four or five stories high. Pourstone walls mask durasteel double walls with circulating coolant flowing freely between. This enables multi-story construction above ground and circumvents the problems of shifting sands during construction of the traditional two- or three-story pits. Virtually all building entrances are equipped with electrostatic repellers (in varying degrees of repair) called sand traps, designed to keep entrances clear of the drifting sands.

Mos Eisley has never been a community fixated on urban planning. In this city, family houses are built next to landing bays and across the street from heavy manufacturing factories. In short, the city is a hodge-podge of construction, with few true neighborhoods. Adding to the confusion is the fact that none of the streets have been surfaced or even named — directions are given by businesses and landmarks instead of street crossings. It's assumed that if someone wants to go somewhere they'll know how to find it.

At the heart of the city are the original spaceport docking bays, along with the power and water distribution plants that supply the city's



John Paul Lona



John Paul Lona

core buildings. The spaceport control tower is located here. Due to Mos Eisley's typical lack of initiative and funds, the collection and distribution water and power network still does not reach the majority of the city. This means that moisture vaporators, seen by the hundreds out on Tatooine's omnipresent moisture farms, can also be found tucked into numerous corners and alleys.

This area is also over the site of the old ore mine and the ground is pocked with shifting and unstable sands. There are minor sinkholes which appear and disappear at the slightest sand-storm.

There are many factories to the north of the city, including Notsub Shipping, Tatooine's largest company. Other industries include limited goods manufacturing (from the specially treated ores), including Droids, landspeeders and sand skiffs.

The Underground

The wholly unregulated part of the city lies beneath Mos Eisley. The abandoned mines and excavations left by the original settlers remain hidden far below the surface. Some corporations use the shafts, crevices, and dead-ends as dumping areas for contraband goods or toxic waste, for discreet agro farming, or for illegal operations. Jabba's cronies use the tunnels as a means to enter and leave the city without being observed, and as rent-free warehouses.

The Imperial government, of course, has some

knowledge of the existence of these tunnels, but no real hint how extensive they are. The new Prefect has neither the interest, the time, nor the personnel to even begin charting a piece of the city which (so far) has not caused him any problems.

Jabba's operatives, on the other hand, have mapped out more of the caverns than all the corporations put together. But this actually means that no more than a fifth of the caverns have been explored ...

Mos Eisley's Government

Mos Eisley is run solely by the dictates of the Imperial Prefect, who has all of his decrees approved by the planetary governor. This system allows the most direct and effective method of bribery and intimidation. Jabba the Hutt has found much influence with Prefect Talmont's government by bribing most of his main advisors.

Law Enforcement (Or The Lack Thereof)

Mos Eisley has a limited police force, newly created through the governor's edict. Some of these officers are former militia members, and now get paid a better salary for the same duties they were already performing. Only now, they work at it full-time and have spiffy new uniforms and vehicles. Although the police force is small, the city still relies upon remaining available members of the local militia (both current and retired) for any real trouble.

Most businesses employ private security guards. And those that do not are relatively new, have other means of protection, have little worth taking, or quickly find the guards' employment well worth the expense.

It is commonly believed that the location of Jabba's Townhouse in the city deters criminals from indiscriminately plying their trade. This is true, but only because Jabba himself hands out neighborhood "licenses" for various gangs and hoods. They help reinforce his will, insure prompt payment of protection money (for those few businesses Jabba feels can afford to pay—he has no desire, so to speak, to lay Bantha fodder in his own backyard), and keep an eye out for information. After all, the Kubaz known as Garindan (Mos Eisley's premiere spy, recently added to Jabba's full-time payroll) can't be everywhere at once.

All these factors combine to make the city a relaxing place for Jabba and his cronies. No one can cause trouble without Jabba hearing of it, either through reports by security guards or by his many, many eyes on the streets. This suits Jabba fine, but makes newcomers very nervous.

Crime & Punishment

Mos Eisley takes a rather leisurely attitude toward crime. *Law and order* is more of a suggestion than a policy. As a result, the courts emphasize localized conditions, welcome attempts at bribery and political influence, and plaintiffs actually expect extremes in style and degree of chastisements. The specifics depend upon who the victim is, who the perpetrator is, and where the crime occurred.

A crime deemed by a judge to be directed against the Empire or the general welfare of its citizens (a term designed to be as vague as possible) typically causes the defendant to receive a strict sentence. However, this claim is normally only levied against non-Tatooine residents who commit offenses against natives; crime committed by a full-time resident against another is likely to be treated as a minor crime.

It is generally difficult to get arrested in Mos Eisley for those who possess a modicum of self restraint and common sense. Minor infractions are often overlooked: this is a place where beings from all across the galaxy meet, mix, and do business. It is unlikely that all who visit have a grasp of local customs and laws. The police are aware that the traders expect more tolerance here in the Outer Rim Territories than in the Core Worlds. Besides, a city which permits its citizens to openly carry small arms is obviously not going to employ a trigger-happy squad of constables.

However, once in trouble, things can get serious very quickly for outsiders. A lawyer experienced in both Tatooine and Imperial law is al-

most a requirement if the defendants are to stand a chance of avoiding a slave gang.

Infractions and Consequences

The most serious infractions committed in Mos Eisley (and which are brought to trial) are as follows, identified by the Imperial Penal Reference. Local Tatooine laws which are on the books — but not necessarily enforced — are indicated by parentheses. While the punishments for these crimes are clustered on the low end of the indicated consequences, and often include attempted rehabilitation, they are listed here for easy comparison of severity.

Class One Infraction

- Conspiracy to overthrow the Empire
- Treason against the Empire
- Attack on a ship
- Aggression against a member of the Imperial Armed Forces

Consequences: Arrest, five to 30 standard years in a penal colony, loss of business or pilot license, possible execution.

Class Two Infraction

- Shipment of high-energy weapons without a permit
- Purchase or transportation of stolen goods
- Possession, purchase or transportation of illegal or restricted items
- (Murder or manslaughter)
- (Fraud or embezzlement against the government or an individual)
- (Aggression against a member of Mos Eisley's police or militia forces)

Consequences: Arrest, fined up to 10,000 credits, five to 30 standard years in jail, probable loss of business or pilot license.

Class Three Infraction

- Attempted bribery of an Imperial official
- (Grand theft landspeeder)
- (Aiding and abetting a known felon)

Consequences: Arrest, fined 250 to 5,000 credits, and/or up to two standard years in jail, possible loss of business or pilot license.

Class Four Infraction

- Purchase or transportation of any narcotic without a permit
- Purchase or transportation of any goods requiring a permit, with said lacking
- Purchase or use of any vessel or vehicle while lacking an operating license
- Possession, purchase or transportation of unrestricted items in quantity without proper taxation
- (Attempted or achieved transportation off planet of manufactured goods containing



Allen Numis

Tatooine ore)

- (Assault)

Consequences: Arrest, fined 175 to 5,000 credits, and/or up to one standard month in jail

Class Five Infraction

- Lack of proper emergency equipment for any vessel or vehicle (including escape pods)
- (Public drunkenness, lewd behavior, violent behavior)

Consequences: Fined 100 to 5,000 credits

Stormtroopers

There is currently a detachment of about 20 stormtroopers in Mos Eisley, deposited here after an unfortunate incident involving a pair of Droids and their young owner from Anchorhead.

The stormtroopers are assigned to the gover-

nor, but they aren't under her direct command. They are answerable directly to Imperial military officials — off-planet and very far away. As a result, they generally determine for themselves what tasks they are supposed to accomplish and what they can choose to avoid. They accompany Governor Aryon and her husband on their trips “into the country” or to Mos Eisley, and perform law enforcement duties that the police and militia can't handle on their own.

Some say the arrangement makes good military sense: the Imperial presence requires a force which can react without emotional ties to those it is subjugating. Others suggest that posting someone here is punishment for incompetence.

The garrison has full access to all equipment possessed by the police force. They also maintain a fleet of military speeder bikes for their own use.

One would suspect that this group of stormtroopers would crack down on smuggling. In fact, if they knew the extent of what was going on, they would attempt a crackdown. However, the local government doesn't talk about the smuggling (since most of the officials would end up executed for corruption and bribery). Jabba's contacts, both in the local government and with the sector Moff, enables him to keep a close watch on the activities of the troopers and protect his operatives — making any smuggling activities that are discovered appear to be small, localized organizations.

Typical Tatooine Stormtrooper

Template Type: Desert Terrain Stormtrooper

DEXTERITY 3D

Blaster 4D, blaster: blaster rifle 5D, brawling parry 4D, dodge 3D+2, melee combat 3D+1

KNOWLEDGE 2D

Bureaucracy 2D+1, intimidation 3D+2, law enforcement 3D

MECHANICAL 2D

Repulsorlift operation 2D+1

PERCEPTION 2D

Search 2D+2

STRENGTH 4D

Brawling 4D+1

TECHNICAL 2D

Force Sensitive?: No

Force Points: 0

Dark Side Points: 0

Character Points: 0-5

Equipment: Heat-reflective armor (+1D from energy, +2D from physical attacks; +1D to *Strength*, -1D to *Dexterity*), comlink, filtermask, blaster rifle (5D damage, 3-30/100/300), blaster pistol (4D damage, 3-10/30/120)

A Quote: “Let me see your identification.”

Speeder Bike

Craft: Aratech 74-Z Military Speeder Bike
Type: Speeder bike
Scale: Speeder
Skill: Repulsorlift operation: speeder bike
Crew: 1
Passengers: none
Cover: 1/4
Cargo Capacity: 3 kilograms
Altitude Range: Ground level – 5 meters
Cost: 7,000 credits
Move: 140; 400 KMH
Maneuverability: 3D+2
Body Strength: 2D
Weapons:

Laser Cannon

Fire Control: 2D
Damage: 3D

Speeder bikes sacrifice altitude for speed, and the 74-Z is no exception. This particular brand of bike is mass-produced for the ever-growing Imperial war machine, and the bikes have even reached the desert world of Tatooine. Here, they are officially restricted to law enforcement personnel. Realistically, only stormtroopers have access to the bikes. They are considered undignified transportation by many local officials, while the stormtroopers consider them excellent craft for the desert terrain.

Police Deployment

The police patrol on foot, scooter and Dewback (see location 10, “Dewback Stables” for statistics).

The police use the scooters because they can chase offenders more effectively, and the scooters can cover more ground. The eight scooters in the possession of the Mos Eisley force are kept in good condition via an extensive maintenance routine conducted at the police station garage.

The police use Dewback beasts only rarely, when scooters aren’t available and there is more territory to be patrolled than a foot patrol can cover.

The chief of police, Lieutenant Harburik, reports directly to Prefect Talmont. He is unhappy with this arrangement, correctly identifying Talmont as an ineffective leader and lazy bureaucrat. However, his military background almost assures that he will blindly follow any imposed procedures. It has not yet occurred to him that his police force outnumbers the Imperial presence. It has occurred to him, however, that the Empire could easily reduce the planet to slag.

Typical Mos Eisley Police Officer

Template Type: Police Officer

DEXTERITY 3D+1

Blaster 3D+2, dodge 4D+2, melee combat

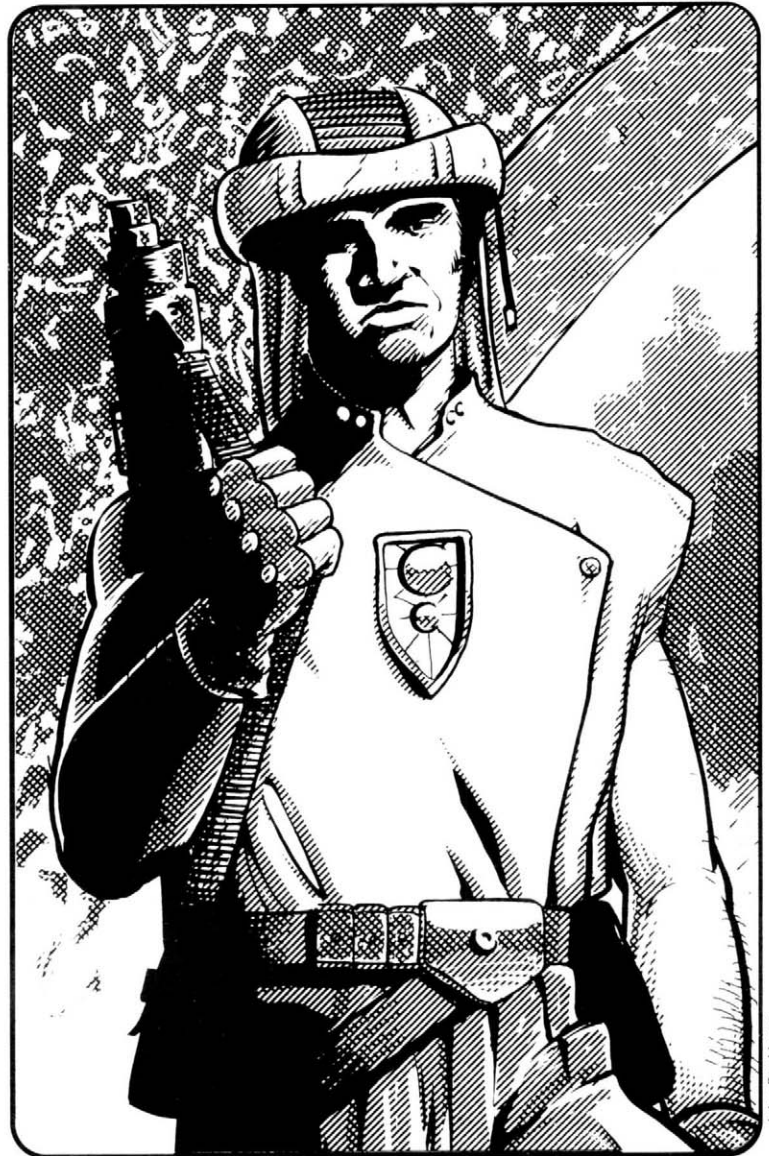

John Paul Lona

4D+1

KNOWLEDGE 3D

Languages 3D+1, law enforcement 5D+2, streetwise 4D

MECHANICAL 2D

Repulsorlift operation 2D+1

PERCEPTION 2D

Search 2D+2, sneak 2D+1

STRENGTH 4D

Brawling 4D+1

TECHNICAL 2D

Security 2D+1

Force Sensitive?: No

Force Points: 0

Dark Side Points: 0

Character Points: 0-5

Equipment: Protective desert clothing, comlink, filtermask, riot armor (+1D from energy attacks), blaster pistol (4D damage, 3-10/30/120),



John Paul Lona

Prefect Eugene Talmont

Template Type: Imperial Prefect

DEXTERITY 3D+1

KNOWLEDGE 4D

Bureaucracy 6D+1, languages 4D+2, law enforcement 3D+1

MECHANICAL 2D+1

Beast riding 5D

PERCEPTION 3D

Bargain 4D+2, command 5D+1

STRENGTH 2D+1

TECHNICAL 3D

Force Sensitive?: No

Force Points: 0

Dark Side Points: 0

Character Points: 2

Description: A slight-built wiry man of medium height, he has an obvious toupee.

Background: Born and bred to serve the Empire, Eugene's unremarkable

background and unsmearing reputation led him from one boring post to another. Talmont was never very thrilled about the post at Mos Eisley — once he learned that the old Prefect, Orun Depp, had been killed by an assassin Droid, he went from apathetic to fearful. Now Eugene makes do, hoping for a transfer from this hideous world.

Personality: Eugene is full of himself and misjudges his importance. The Prefect is nearsighted, but is too vain to wear corrective lenses. He is impatient with his subordinates when tense, but otherwise treats them well.

Objectives: To increase his prestige while avoiding Governor Tour Aryon.

A Quote: "I see! They think they can get away with it, but they have yet to deal with Prefect Talmont!"

force pike (4D damage).

A Quote: "All right, break it up. Both of you get out of here and I won't report this. Again."

Dewback

DEXTERITY 3D

PERCEPTION 2D

STRENGTH 4D

Brawling 4D+1

Orneriness: 3D

Move: 35; 100 KMH (during day)/ 7; 20 KMH (at night)

Size: 2.1 meters at the shoulder

These lizards are huge omnivores native to Tatooine. Active during the heat of the day, they become docile and sluggish at night. The police utilize these animals when patrolling outside the city proper. They are less likely to be affected by sandstorms than are landspeeders, usually ignoring the storm's effects as they stride to their destination. When Dewbacks eat meat, their usual prey is Womp Rat-size or smaller.

Lieutenant Harburik

DEXTERITY 4D+1

Blaster 6D+1, brawling parry 4D+1, dodge 6D+2, grenade 4D+2, melee combat 5D

KNOWLEDGE 3D

MECHANICAL 2D

Beast riding 3D, repulsorlift operation 4D

PERCEPTION 3D+1

Gambling 6D, search 5D+1

STRENGTH 2D+1

Brawling 4D+2

TECHNICAL 2D

Computer programming/repair 5D, demolition 4D+2, security 5D

Force Sensitive?: No

Force Points: 1

Dark Side Points: 0

Character Points: 6

Equipment: Armored blast vest (+1D to front from both physical and energy attacks), heavy blaster pistol (5D damage, 3-7/25/50), comlink, holographic imager, macrobinoculars.

Description: A large, well-muscled man. He would be devastatingly

handsome except for the vicious look in his eyes.

Background: Harburik represents everything that is reprehensible about the New Order. Harburik originally resented being posted as personal liaison to the Prefect, especially as he had to assume the dead Prefect's responsibilities while Mos Eisley waited for a replacement. He soon realized that the power vacuum could be turned to his advantage and now enjoys his new position as Chief of Police. He likes being a large fish in a small pond. His biggest problem is Prefect Talmont's pompous and overbearing demeanor. He has not yet decided how to go about replacing the man with someone more capable, but a trend of Prefects being killed by assassin Droids is appealing.

Personality: Crass, rude, and cruel are the anchor points of Harburik's personality. He is well known for abusing every subordinate who comes into contact with him.

Objectives: To keep his power base from transferring to Prefect Talmont.

A Quote: "No problem. You don't want to tell me who paid you off, so I'll just take this weapon off the stun setting."



John Paul Lona

Mos Eisley Central Sector



Paul Jaquays

Locations

1. Docking Bay 94

Docking Bay 94 is typical of the numerous landing bays scattered throughout the city: little more than a large pit gouged in the soil, with a simple entrance ramp for removing cargo and three sets of stairs to the surface (one is directly to street level, while the other set runs by location 2, "Spaceport Customs," described on page 31). Much of the bay is below ground level — the floor of the bay itself is 10 meters down, as are the offices and maintenance facilities.

The bays are small and old, harkening back to the time when landing craft were mostly shuttles to orbiting ships or small tramp freighters, such as the widely-found YT-1300. They were designed to withstand the backblast of the older *Orion*-style ion sublight engines. Since most modern ships are equipped with the much more efficient Hoersch-Kessel ion drive and repulsorlift units for fine maneuvering, the pits are no longer necessary but they remain in use rather than spend the credits to build new facilities.

Ohwun De Maal, with his mate Chachi, are the proud owners of Docking Bay 94 and are considered to run some of the best independent bays in Mos Eisley. Like the other independents, the frequency of the De Maal's business is directly tied to "gifts" bestowed upon Jabba the Hutt. But since the crime lord also insures protection from harassing thugs and busybody gov-

ernment officials, the De Maals (until recently) did not begrudge the high insurance premiums.

Mos Eisley's docking bay rates are far below galactic standard — Docking Bay 94 charges 25 credits a day for the bay (raised twice from the original 20). Restocking and resupply fees are 8 credits per person's worth of consumables for one day (about 20% below standard rates); fuel cells are replaced at a cost of 10 credits per cell

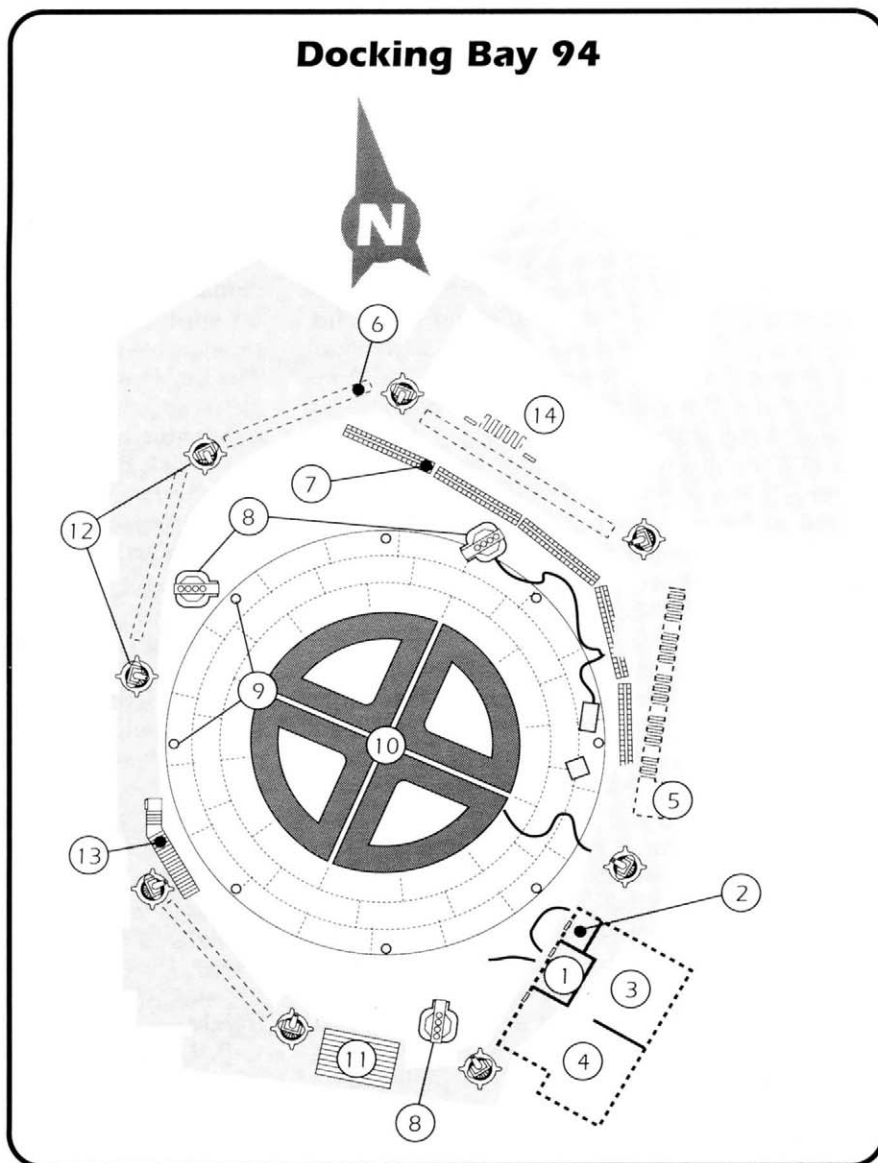



Mike Vizardi

(a standard light freighter has 50 cells).

The De Maals employ three part-time assistants who load and unload cargo, service the ships which come in, do moderate cleaning and maintenance chores, perform Mynock inspections, and supervise delivery of goods. They also work at the De Maals other docking bays and warehouses. They also have an odd assortment of Droids underfoot who seem always to be busy working *at* things, but never seem capable of finishing a job without organic help.

1. Office: This room contains the transmitter for scheduling services with spaceport control, as well as filing and coordination computers. This room also holds all authorization permits needed to operate the bay.

2. Restroom: Public restroom. Usable but not pretty.

3. Maintenance Garage: This room holds most of the machinery needed to service the ships which arrive here. It includes two binary load lifters for transporting cargo to and from a ship's hold. If Geordi Hans from Spaceport Speeders is around, he'll usually be found in here, tinkering.

4. Ship Supplies: Everything from oxygen to lubricant to basic proteins (for ship food converter systems) are stored here. The materials are purchased in bulk and meted out to ships as part of the common usage fee for the landing bay.

5. Passenger Entrance: All bipedal crew members and passengers use this accessway to and from the bay. At the top of the stairs is a blast door (*Strength* 6D Character-scale) which can be sealed, but is usually left open while a ship is docked. Beggars and flim-flam artists (playing

simple shell games) mark off territory and position themselves to be the first to take advantage of any new arrivals, while pickpockets watch to see who has money. It is unlikely that any of these characters has any useful information, but occasionally one of Jabba's or Valarian's cronies can be spotted sulking about. The alley has been quiet as of late, with the reduced traffic to Bay 94. The De Maals would like to see the alleyway kept clear of such riffraff, but they have little chance of being able to get anything done about it.

6. Back Blast Ceiling Vent: These vents were designed to soften the discharge of radiation from *Orion* ion sublight engines. Although the De Maals keep the vents clear (as per regulations), there hasn't been a use for them for over seventy years.

7. Sand Trap: A lot of sand gets kicked up when a craft enters or leaves the bay. These electrostatic repellors help restrain the sandstorm to the pit itself: especially important if the door is open at the top of the passenger entrance stairway.

8. Fusion Generators: The three converters sitting out in the bay are hooked into the huge fusion generator mounted at back of the maintenance garage. They are used to refuel ships, recharging the ship's power cells. The De Maals charge the going rate, or ten credits for recharging one cell per hour. A typical empty light freighter can be charged in 50 hours.

9. Landing Lights: The eight landing lights mark off the landing circle in Docking Bay 94 for night landings.

10. Docking Pit: The floor of the bay is heavily

reinforced durasteel, and the walls (not needing to handle as much weight) are lighter pourstone.

11. Entrance Ramp: This powered ramp is used to transport cargo or non-ambulatory passengers to and from the bay floor to the surface. When fully extended the ramp runs nearly to the center of the pit floor. It exits into a wide service alley.

12. Tractor Beams: Built into the bay wall at ground level, these eight small standard tractor beam dishes can grab ships that are within 100 meters of Docking Bay 94. The tractor beams are linked, with a combined *Strength* rating of 2D (starfighter scale): insufficient to hold a ship against the pilot's will, but strong enough to guide a willing ship to its berth.

Two of the beams are starting to give out, so one of the De Maals must be on hand to run the tractor beam computer and manually compensate for their weakened pull. The computer is located in the Office (location one) and the operator must watch through video monitors.

13. Service Entrance. This entrance, a simple stairwell leading to a blast door at surface level, was originally built with the bay, but the De Maals have never used it. The blast door leads to a short hallway, which opens into the street.

14. Customs Inspector's Office. Discussed in location 2, "Spaceport Customs," page 31.

The De Maals

The De Maals also own five other docking bays (27, 43, 67, 71 and 86), a service shuttle, and eight nearby warehouses, from which they make most of their profit. The warehouses charge 5 credits per ton of cargo storage per week (average for Mos Eisley), and each can hold 250 tons of cargo.

Current relations between the De Maals and Jabba are strained. One of their regular customers, a Corellian smuggler who regularly worked for Jabba, defied the quarantine of Mos Eisley and took off from their bay. It took almost an entire season for the De Maals to prove their innocence in the affair — although it may just be that the authorities waited until things quieted down to hand back their docking permit.

Nonetheless, the Hutt was supposed to handle such interferences. Although he arranged for bail while the charges were pending, they were required to pay it back (with 25% interest — a relatively modest rate for Jabba). The loss of a season, and their good name, has not been overcome. Their business is still only three-fourths of what it should be. Chachi and Ohwun haven't quite decided what to do about it, nor have they figured out how to collect on the outstanding debt of the formerly-honorable Corellian who skipped out on them.

Chachi De Maal

Template Type: Duros Docking Bay Owner

Loyalty: To Ohwun De Maal

Height: 1.8 meters

Species: Duros

Sex: Female

Homeworld: Duro System, Jivv Space City

Age: 35

DEXTERITY 3D

Blaster 4D+1, blaster: blaster pistol 5D+2

KNOWLEDGE 2D+1

Alien species 3D+1, alien species: Humans

5D, languages 3D

MECHANICAL 2D

Communications 3D+2, repulsorlift operation 4D+1, space transports 6D

PERCEPTION 2D+2

Bargain 5D+2

STRENGTH 3D

TECHNICAL 3D

Computer programming/repair 4D, space transports repair 7D+2

Force Sensitive?: No

Force Points: 0

Dark Side Points: 0

Character Points: 8

Ohwun De Maal

Template Type: Duros Businessman

Loyalty: To Chachi De Maal

Height: 1.8 meters

Species: Duros

Sex: Male

Homeworld: Tatooine

Age: 38

DEXTERITY 3D

Blaster 3D+2, dodge 5D+1

KNOWLEDGE 2D+1

Alien species 3D, alien species: Humans

4D+2, business 4D+1

MECHANICAL 3D

Astrogation 4D, repulsorlift operation 6D+1,

sensors 3D+2, space transports 5D, space

transports: YT-1300 7D, space transports:

Service Shuttle 23K 7D+2

PERCEPTION 2D+2

Bargain 5D+1

STRENGTH 2D+1

TECHNICAL 3D

Droid programming 5D+1, Droid repair 5D,

medicine 4D, space transports repair 7D+2

Force Sensitive?: No

Force Points: 0

Dark Side Points: 0

Character Points: 10

Special Abilities:

Starship Intuition: Duros make very capable starship pilots. When a character is generated, he may only place 1D in the following skills, but



Mike Vilardi

Arjon F.M.P.

Template Type: Flighty Card Shark

Loyalty: To herself and then the De Maals

Height: 1.5 meters

Species: Human

Sex: Female

Homeworld: Ord Mantell

Age: 24

DEXTERITY 4D

Blaster 4D+2, dodge 5D+2

KNOWLEDGE 3D

Languages 4D+1, planetary systems 5D

MECHANICAL 2D

Astrogation 3D+1, space transports 4D

PERCEPTION 3D

Con 4D, con: card sharking 5D+2, gambling 6D+1, persuasion 5D+2

STRENGTH 2D

Brawling 5D+1

TECHNICAL 2D+1

Computer programming/repair 3D

Force Sensitive?: No

Force Points: 0

Dark Side Points: 0

Character Points: 4

Equipment: Comlink, hold-out blaster (3D+1 damage, 3-4/8/12), card deck, clothes.

Description: Arjon F.M.P. has golden-

yellow skin and almond-shaped eyes. She dresses in typical Tatooine browns and tans.

Background: Arjon F.M.P. ("F.M.P." to her friends) stopped at Tatooine for a layover and never boarded her connecting flight. She no longer is sure why she stays: her home is long gone, her lover has no doubt stopped wondering what happened to her, and her own memory of that life has faded. Arjon has taken up card sharking in the alley directly adjacent to Docking Bay 94. She has a continuing feud with the begging Jawa further down the alley.

Objectives: Keep her spot in the alley, keep food in her belly and an eye out for news.

Personality: F.M.P. is a typical gregarious con artist, with no real scruples about deceiving a naive passerby. She does not otherwise engage in stealing: pickpocketing, for example, offends her.

A Quote: "Step right up. Choose your card, let me guess which one it is. If I'm wrong, you win the pot. I've got a one in sixty-three chance. C'mon, place your bets."

receives 2D in those skills: *archaic starship piloting, astrogation, capital ship gunnery, capital ship shields, sensors, space transports, starfighter piloting, starship gunnery, and starship shields*. This bonus also applies to any specializations.

Equipment: Comlink (on belt), work clothes, various starship repair tools, datapad, 100 credits, magnetic grapplers, fusion welder (5D damage, 1 meter range)

Description: Chachi and Ohwun De Maal appear to be unremarkable Duros. Their blue skin, noseless faces, similar body types and slitted mouths contribute to their undifferentiated appearance. This makes them difficult to distinguish from each other.

Background: The De Maals, it seems, have always owned Docking Bay 94. Actually, Ohwun's parents owned it before him, and his grandmother before them. The De Maals are hard-working, decent beings, who want nothing more than to have the gangsters and the civil war go away. As this does not look likely, they are considering alternate avenues, but aren't really sure what it is that they want.

Personality: Chachi and Ohwun are devout Duros, who follow in the traditions of their folks. This means walk quietly, talk quietly, play fairly.

Objectives: To stay on Mos Eisley with their friends and to make a decent, honest living.

A Quote: "Sure, we can have you refueled in less than a day. Your fuel cells just need some topping off. Glad to oblige for a good customer, Han."

The Service Shuttle

Many landing bay services can gain additional income by using service shuttles to refuel large, non-atmospheric craft. In addition, some landing bay companies offer shuttle service between the surface and the spacecraft. The De Maals are no exception.

They own a dilapidated, but sturdy Gallofree Yards service shuttle which has room to transport small groups planetside and enough medical supplies to aid small crews in distress. They charge 10 credits to restock the equivalent of one day's worth of supplies for one person (minimum charge of 250 credits). Replacement fuel cells are

replaced at a flat 25 credits each. Shuttle fares are 20 credits per person one way.

Docking Bay 94 holds a contract with Spaceport Speeders to regularly inspect and service the service shuttle, as well as their pair of binary load lifters.

Gallofree Yards Service Shuttle

- Craft:** Gallofree Yards Service Shuttle 23K
- Type:** Orbital service shuttle
- Scale:** Starfighter
- Length:** 18 meters
- Skill:** Space transports: Service Shuttle 23K
- Crew:** 1
- Crew Skill:** Space transports 4D
- Passengers:** 6*
- Cargo Capacity:** 1 metric ton*

- Consumables:** 1 day
- Hyperdrive Multiplier:** none
- Hyperdrive Backup:** none
- Nav Computer:** none
- Maneuverability:** 1D
- Space:** 2
- Atmosphere:** 225; 650 kmh
- Hull:** 1D+1
- Shields:** None
- Sensors:**
 - Passive:* 10/1D
 - Scan:* 15/1D+2
 - Search:* 20/2D
 - Focus:* 1/2D+2
- Weapons:** None

*Service shuttle can hold *either* passengers or cargo.

2. Spaceport Customs

This small, dingy office, adjacent to Docking Bay 94, serves as a field office for customs officers who must work in the inner sections of Mos Eisley (the central office is part of location 23, "Mos Eisley Spaceport Control Tower" several blocks away).

Due to the rather lax customs regulations of Mos Eisley, this building is vacant most of the time — dust has settled throughout the rooms and each has a stuffy smell, as if the ventilators have broken down (they have).

There are three doors to get into the building: one on a second floor balcony, one opening in the streets of Mos Eisley, and one along the stairwell corridor leading from the surface to Docking Bay 94. Each has a *Strength* 3D door with a lock requiring an *Easy security* roll to open.

1. Security Chief's Office. This office has never been used, but it is slated for Mos Eisley's Security Chief, who never leaves the Spaceport Control Tower if he can help it. The room has a desk and a chair; the computer was stolen long ago by a deputy customs officer.

2. Assistant's Office. The Security Chief's assistant, Gevrell, works in this office. He is only found here when he's trying to hide from his boss and avoid getting work done. Most of the time he simply drops datadisks on the desks of his assistants (rooms three and four).

The room has a desk, a reclining chair, a computer, a holographic portrait of Gevrell's wife (an unattractive woman of indeterminable age), along with a broken fan. There is also an audio comm terminal (this system is used throughout the city).

3, 4. Inspectors' Offices. All of the less experienced inspectors operate out of these offices — there are eight desks per room (all seem to be in

use, but that's because when an inspector runs out of room on his desk, he simply uses the one next to him). The desks are piled high with datadisks, confiscated goods (which are supposed to be in the supply room), broken gear and personal effects.

5. Supply Room. This room has two chambers, but there is no door between them. The left chamber has supplies for inspectors — blaster pistols (4D damage), combat vests (+2 versus blasters, +1D versus physical attacks), inspectors' badges (just have a computer imprint information on the badge and insert a photo), helmets with comlinks, belts for carrying tools, various inspection tools, datapads with all customs regulations and fines pre-entered, blank data disks, blaster power packs and other items that would be of use. The right chamber has evidence that has been confiscated from smugglers and such: deactivated Droids, weapons, datapads and computers, clothing, bootleg entertainment holotapes, computer components, parts for illegal starship engine modifications and the like.

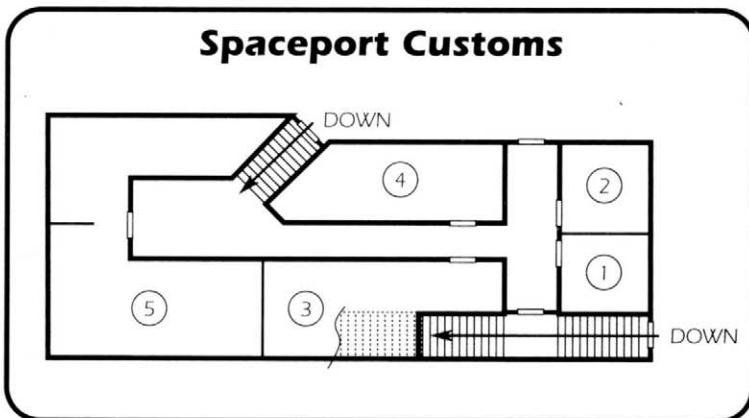

3. Spaceport Speeders

The Spaceport Speeders shop, southeast of Docking Bay 94, is an unassuming affair. It offers a motley collection of speeders of all shapes, sizes, and degrees of repair, and the occasional oddball speeder bike or sub-orbital craft. The shop itself contains an average assortment of tools and equipment.

Unut Poll, the Arconan proprietor, has a small apartment below the shop. He employs a young Human mechanic named Geordi Hans and a salesman, Wioslea, who in addition to her sales skills, is fluent in many languages. In addition to sales, Spaceport Speeders also rents and repairs vehicles.

Spaceport Speeders has repair contracts with five local docking bays for their loading equipment. In addition, those docking bays refer repair requests to Unut.

Geordi Hans is the real star of Spaceport Speeders. He has his own landspeeder, which is more often up on blocks than actually in use. Geordi prefers tinkering—either with his own vehicle or someone else's. He is well-known for his mechanical ability, and the locals in the area often seek his advice on engines, or pay him to repair their speeders.

Speeder Sale!

The speeders described are samples of the kinds of vehicles available for sale by Spaceport Speeders; new craft come in and go out over the course of a few seasons. In many cases, they have been modified by either the original owner or by Geordi; some have been so battered by use that their game stats are lower than typical vehicles of that model.

The prices listed reflect the price at which Unut is prepared to sell. Unut is fairly reasonable as far as pricing. The listed price is often 5-10% lower than what a comparable reseller across town might charge. Many of these speeders were seen in Mos Eisley, or in the Lars garage during *Star Wars Episode IV: A New Hope*.

Incom T-16 Skyhopper

Craft: Incom T-16 Skyhopper

Type: Skyhopper

Scale: Speeder

Length: 5.2 meters

Skill: Repulsorlift operation: skyhopper

Crew: 1

Passengers: None

Cover: 3/4

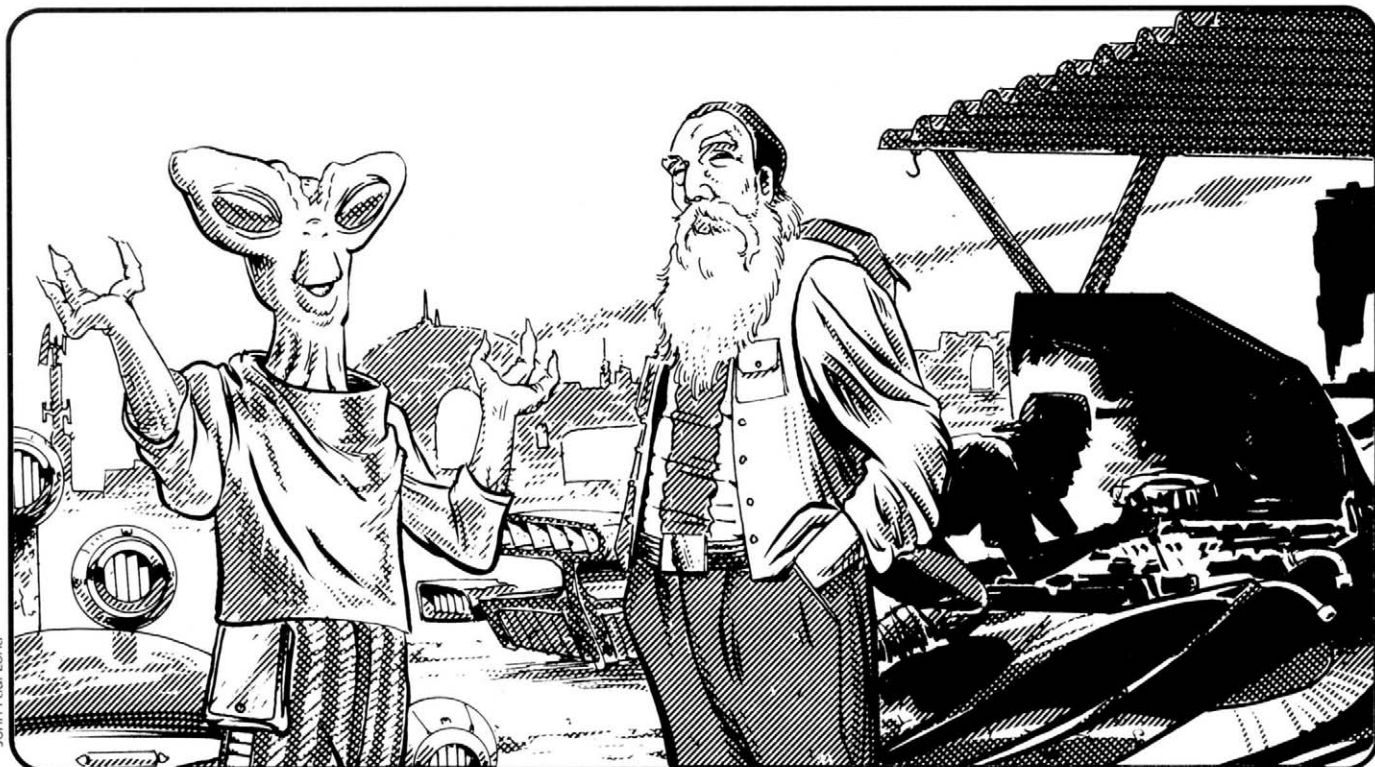

John Paul Lona

Unut Poll makes an art of negotiating with leery customers.

Cargo Capacity: 25 kilograms
Altitude Range: Ground level–150 km
Cost: 7,100 credits (used); 300/day (rental)
Maneuverability: 3D
Move: 450; 1300 KMH
Body Strength: 2D+1

Weapons:
Four Stun Lasers (fire linked)
Fire Arc: Front
Skill: Vehicle blasters
Fire Control: 0D
Range: 50-300/800/1.5KM
Damage: 2D*

*Stun damage only

Speed and agility are the highlight of this older but popular skyhopper. It uses mechanical control flaps to brake and change direction, allowing it to turn on a coin without slowing. The T-16 is equipped with ion afterburners in addition to its standard repulsorlift engine, enabling it to achieve suborbital flight.

Its vertical panel extends down and forward, visually separating the front windshield into two halves. This can be unnerving to the inexperienced pilot, but the heads-up tactical holodisplay flawlessly projects a simulation of the obscured terrain.

This particular T-16 was retrofitted with a bank of four forward-mounted stun lasers, powerful enough to stun small animals. When Unut purchased it, someone was in the midst of overhauling its engine; Geordi Hans spent the better part of two days reassembling the engine and it now runs flawlessly.

Although Unut rarely worries about ownership of the vehicles he purchases, the group of Jawas who sold it to him didn't seem the type to deal in airskimmers. Nevertheless, everything seemed in order, and Unut needed new inventory.

SoroSuub XP-38A Speeder

Craft: SoroSuub XP-38A
Type: Landpeeder
Scale: Speeder
Length: 7.4 meters
Skill: Repulsorlift operation: landspeeder
Crew: 1
Passengers: 2
Cover: 3/4
Cargo Capacity: 5 kilograms
Altitude Range: Ground level–1 meter
Cost: 1,600 credits (used); 45/day (rental)
Maneuverability: 2D
Move: 35; 100 KMH
Body Strength: 2D
Weapons: None

SoroSuub's XP-38 is the currently the most advanced and hottest-selling landspeeder on the market. Performance (it is capable of reaching

320 kilometers per hour), along with a stylish reclining seat and aerodynamic design, easily keeps it ahead of the competition. Their popularity has even reached Tatooine: a few have been sighted in the streets of Mos Eisley. The XP-38A is the precursor to this hot rod, and is far more common. The XP-38A ground speeder is designed more as a utility vehicle than a racer. Technically capable of seating three (one uncomfortably), it is usually advertised as a two-seater.

Just like the XP-38, this model sports the now-famous autopilot shaped to resemble an Astromech Droid. Geordi advised Unut that it no longer runs as fast or as well as it did when it was new. It also has a broken sensor array which Geordi has been unable to fix — much to his consternation.

This heavily-used landspeeder was one of two sold to him by a group of eager Jawas. It wasn't until a day later, when cleaning out the speeder, that Unut found evidence of a previous owner. Wedged behind the rear seat was a holocube showing a family of three: a boy of about fifteen with his parents. The more Unut studied the picture, the more he thought he recognized the boy. Unut keeps the holocube on the desk in his office, having decided to make a hobby out of discovering who the speeder used to belong to. So far he has had no luck.

Bespin Motors Void-Spider TX-3 Air Taxi

Craft: Bespin Motors Void-Spider TX-3
 Air Taxi
Type: Landspeeder
Scale: Speeder
Length: 7.6 meters
Skill: Repulsorlift operation: landspeeder
Crew: 1
Passengers: 1
Cover: 3/4
Cargo Capacity: 7 kilograms
Altitude Range: Ground level–5 meters
Cost: 12,000 (new); not for rental
Maneuverability: 3D+1
Move: 105; 300 KMH
Body Strength: 1D+1
Weapons: None

Bespin Motors. The name signifies attention to detail, quality and superior performance, both for personal and commercial vehicles.

The TX-3 is powered by a highly efficient Quadrex Corestar repulsorlift engine, and solar panels along the exterior of the craft power an induction cooling system.

The unusual bubble domed vehicle looks cramped when viewed from afar, but actually affords more leg space than the popular XP-38.

The occupants sit side by side, facing in opposite directions.

Mobquet A-1 Deluxe Floater

Craft: A-1 Deluxe Floater landspeeder
Type: Landspeeder
Scale: Speeder
Length: 7.1 meters
Skill: Repulsorlift operation: landspeeder
Crew: 1
Passengers: 1
Cover: 1/2
Cargo Capacity: 10 kilograms
Altitude Range: Ground level–2 meters
Asking Price: 6,500 credits (new); 150/day (rental)
Maneuverability: 1D+1
Move: 55; 160 KMH
Body Strength: 2D
Weapons: None

The Deluxe (as it is referred to) is not the fastest, sleekest, or most desirable craft available. Instead, this rocket-like craft offers two things: reliability, and low cost. Intended by Mobquet Industries to be a craft that anyone could afford, they kept the machine down to the basics. The passengers sit one behind the other. The exhaust outlets are almost completely outside the main body: it is possible to get burned getting out of a Mobquet Deluxe. The inlet ports on the front of the vehicle betray its forced-air-cooled design. Unfortunately, this system is well known for failing to prevent outside odors from filtering into the canopy.

It is lacking numerous luxuries that are standard on most other craft: autopilot, entertainment systems, navigation beacon sensor, and on-board computers. The company's marketing efforts have emphasized affordability: despite its low cost, the Deluxe still retains a high resale value. The body of the Mobquet often disintegrates before the engine quits.

Unut ordered two of this particular model after getting in a used original Mobquet A-1, which sold within two days. It appears to have been a mistake: these unremarkable models, despite an excellent price (reduced twice so far), have been here for two seasons.

Ubrikkian 9000 Z001

Craft: Ubrikkian 9000 Z001
Type: Landspeeder
Scale: Speeder
Length: 6.8 meters
Skill: Repulsorlift operation: landspeeder
Crew: 1
Passengers: 2
Cover: 3/4
Cargo Capacity: 50 kilograms
Altitude Range: Ground level–3 meters

Asking Price: 7,500 (rebuilt); 85/day (rental)
Maneuverability: 3D+1
Move: 55; 160 KMH
Body Strength: 2D+1
Weapons: None

The rounded design of the 9000 reflects the species this model was aimed at: the amorphous Ugors. It has viewports on all sides. While the original model failed to attract very many buyers (despite several design features, including a unique boarding system: the craft elevated, allowing the Ugor to flow under and up into the craft, which sealed after boarding), Ubrikkian Yards was unfazed. The company modified the original concept, and released the 9000 Z001.

The Z001 has a trio of seats around a central shaft, presenting an unresolved problem of movement sickness. The Z001 is entered by elevating the chassis up from its base. The occupants simply walk under it and allow it to lower around them.

It possesses incredible maneuverability for a landspeeder, something Ubrikkian Yards touts when complaints surface about its speed.

SoroSuub XP-291 Skimmer

Craft: SoroSuub XP-291 Skimmer
Type: Landspeeder
Scale: Speeder
Length: 6.5 meters
Skill: Repulsorlift operation: landspeeder
Crew: 1
Passengers: 3
Cover: 3/4
Cargo Capacity: 10 kilograms
Altitude Range: Ground level–2 meters
Asking Price: 3,500 credits (used); 30/day (rental)
Maneuverability: 2D+1
Move: 80; 230KPH
Body Strength: 2D+2
Weapons: None

To look at, you'd never think this speeder would amount to much. Its flat bullet shape masks the forced-air-cooled system (with the same odor problems as the Mobquet A-1 Deluxe Floater). The engines are not manufacturer's original: Geordi thinks that the originals were blown, but the replacements offer better performance than the manufacturer's specs. Unfortunately, the condition of the chassis masks the care with which the engines were handled, making this a hard sell. Unut originally priced the speeder at 4,000 credits. After three seasons, it is now down to 3,500.

Ikas-Adno Starhawk

Craft: Ikas-Adno Starhawk 2b
Type: Speeder bike
Scale: Speeder
Length: 5 meters

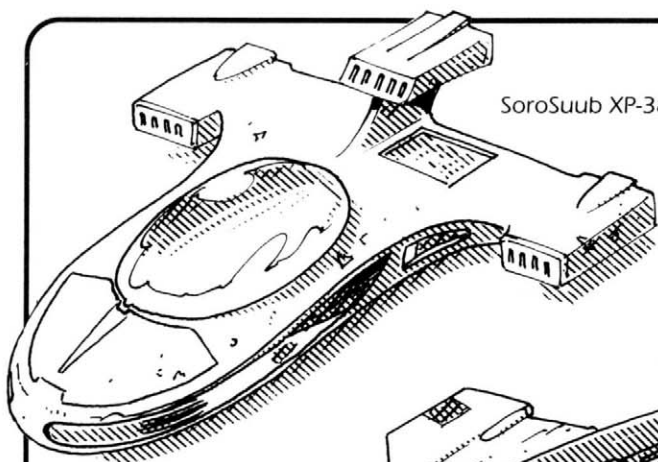

SoroSuub XP-38A Speeder

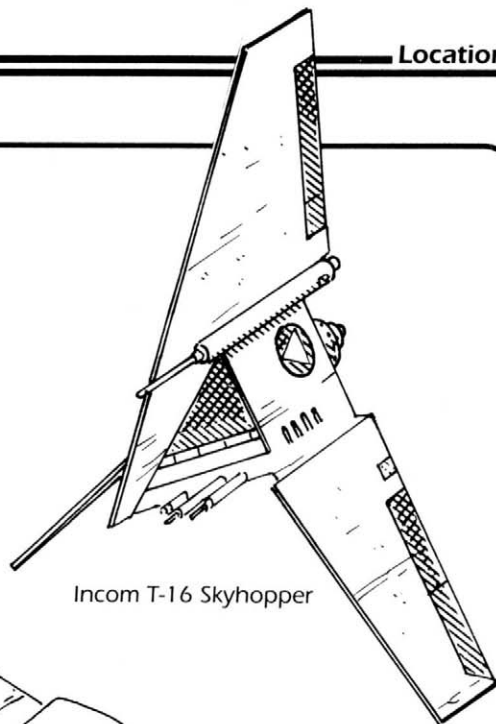

Incom T-16 Skyhopper

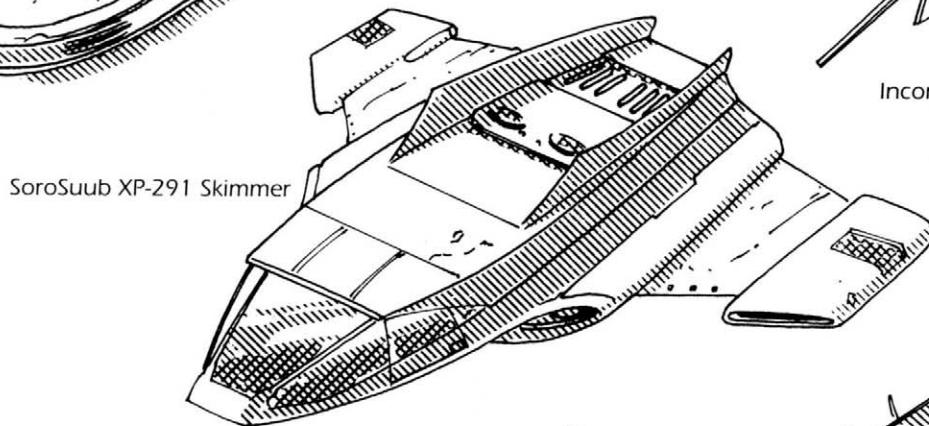

SoroSuub XP-291 Skimmer

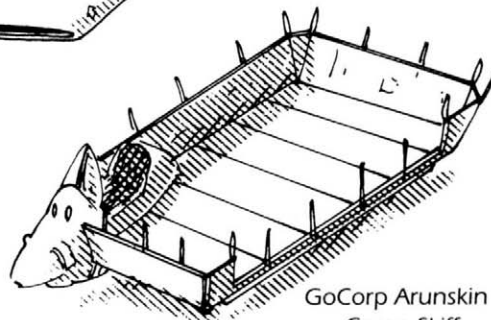

GoCorp Arunskin 32
Cargo Skiff

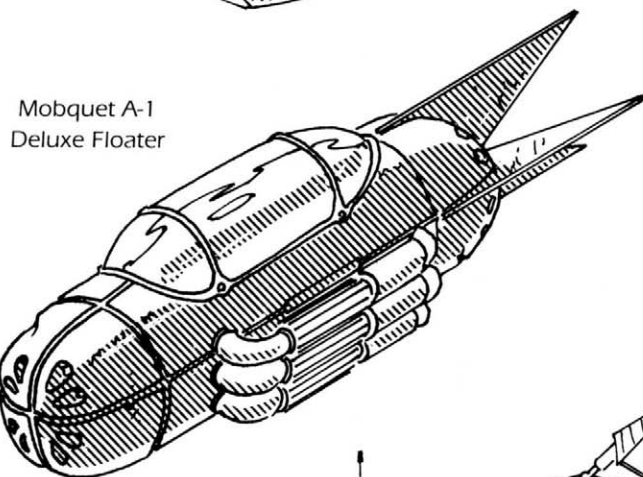

Mobquet A-1
Deluxe Floater

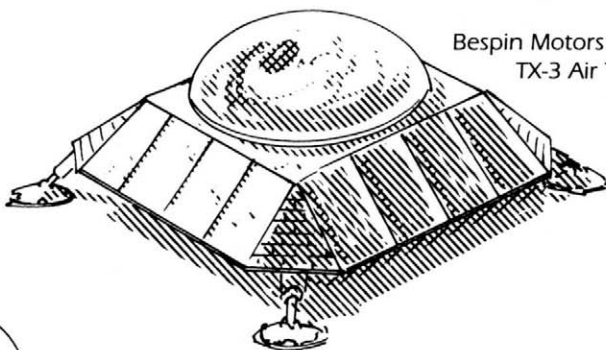

Bespin Motors Void-Spider
TX-3 Air Taxi

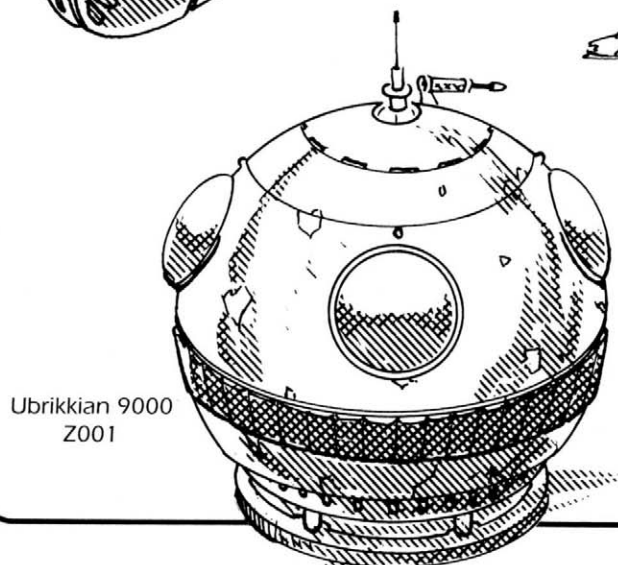

Ubrikkian 9000
Z001

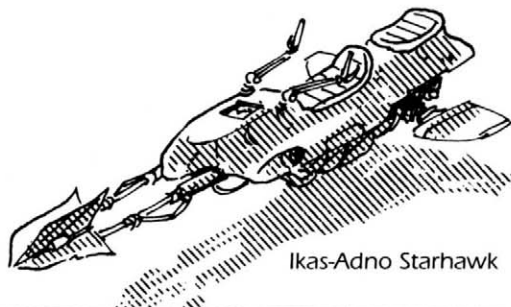

Ikas-Adno Starhawk

John Paul Lona

Skill: Repulsorlift operation: speeder bike
Crew: 1
Passengers: None
Cover: 1/4
Cargo Capacity: 3 kilograms
Altitude Range: Ground level–12 meters
Asking Price: 3,600 (used); not for rental
Maneuverability: 3D+1
Move: 125; 360 KPH
Body Strength: 1D+1
Weapons: None

Rarely does Unut price a vehicle based on market demand instead of quality, but the out-of-production Starhawk is not just any bike. It has the same mystique afforded to it as other legendary vehicles of old. Songs are sung and stories are told of Starhawks being passed down from parent to child. At Bestine's annual Starswoop Biker's Fair, which is ostensibly for swoops, the Starhawks are the highlight of the show.

The Starhawk is not the fastest speeder bike, but it is among the most graceful, and one of the most sought-after, especially by collectors.

Geordi has been carefully eyeing the bike ever since it showed up. Unut hasn't admitted this to anyone else, but one of the reasons the bike is priced so high is to discourage sales. He has decided if it does not sell in the next season, he will give it to Geordi as a birthday gift.

GoCorp Arunskin 32 Cargo Skiff

Craft: GoCorp Arunskin 32 Cargo Skiff
Type: Skiff
Scale: Speeder
Length: 17.2 meters
Skill: Repulsorlift operation: skiff
Crew: 1
Passengers: 14
Cover: 1/4
Cargo Capacity: 100 metric tons
Altitude Range: Ground level–50 meters
Cost: 9,000 credits (used); 100/day (rental)
Maneuverability: 1D
Move: 30; 90 KPH
Body Strength: 1D+2
Weapons: None

The Ubrikkian Bantha II Cargo Skiff's workhorse reputation was well known. Unfortunately, it was also well known for its rather flimsy chassis. The upstart GoCorp company attempted to capitalize on that weakness by offering the Arunskin 32: it is equipped with a tougher shell without losing the Bantha's primary selling point of cargo capacity.

This particular cargo skiff was fitted with a complete Wengel communications/entertainment system. This equipment stands out in an otherwise utilitarian craft. Unut isn't quite sure what to make of it, and has done little to actually push the sale.

Unut And Geordi

Unut first met Geordi Hans when he was a street urchin, repairing speeders outside bars in order to get something to eat. The Arconan instinct for insuring the safety of their young influenced Unut to look out for the scrawny kid from Motesta township, and they now share a warm, almost family relationship, with Unut occasionally referring to Geordi as a "hatchling" — a young Arconan.

Unut has an excellent reputation in the city, even if he is stingy with his credits. Unut, as a small businessman, has been able to steer clear of most of the gang violence and inner conflicts.

Due to a great tragedy in his past, Unut works for the Rebel Alliance, and is its main contact in Mos Eisley. However, he is extremely cautious in his activities in order to avoid detection.

Unut Poll

Template Type: Arcona Refugee
Loyalty: To himself, Geordi Hans and the Rebel Alliance

Height: 1.6 meters

Species: Arcona

Sex: Male

Homeworld: Cona

Age: 70+

DEXTERITY 2D+1

KNOWLEDGE 1D+1

Alien species 3D, business 2D+2, languages 4D+2, languages: Basic 5D, streetwise 3D+2, planetary systems 2D+1, planetary systems: Alderaan 4D+1, planetary systems: Cona 3D+2, planetary systems: Coruscant 3D, planetary systems: Tatooine 4D+2

MECHANICAL 1D+2

Repulsorlift operation 4D

PERCEPTION 2D+1

Bargain 4D+1, con 6D+2

STRENGTH 2D+2

Digging 4D

TECHNICAL 1D+2

Computer programming/repair 3D, repulsorlift repair 2D

Special Skills:

Strength skills:

Digging. Time to use: One round or longer. This skill is used to dig through ground or other substances.

Special Abilities:

Senses: Arcona have weak long-distance vision (add +10 to the difficulty when making checks requiring vision at distances greater than 15 meters), but have excellent close range senses, because their eyes, their sense of smell and a heat-sensing bulb provide detailed information on close-range movement, the presence of heat sources and such (add +1D to *Perception* for

checks closer than 15 meters when using heat, smell or movement).

Thick hide: Arcona have tough, armored hides that add +1D to *Strength* against physical attacks (not laser or energy).

Talons: Arcona have sharp digging talons which add +1D to *climbing*, *Strength* (in combat) or *digging*.

Salt weakness: Arcona are easily addicted to salt: if an Arcona consumes salt, he must make a Very Difficult *willpower* not be addicted and need salt at least once a day or suffer -1D to all actions.

Force Sensitive?: No

Force Points: 2

Dark Side Points: 0

Character Points: 20

Equipment: Hold-out blaster (3D+2 damage, 2/4/8), ammonia tablets, clothing, 200 credits, datapad (pre-programmed with rental contracts), disguise kit.

Description: An older Arconan, Unut's face is careworn and gentle, characteristics which are obvious no matter what species the observer happens to be.

Background: Unut Poll is not really who he seems to be. The original Unut owned Spaceport Speeders — the "new" Unut is a refugee of the Galactic Civil War. No one knows his true name or identity.

The new Unut is old enough to have witnessed the fall of the Republic. After the Empire executed his wife and children in the mistaken belief that they were involved in a local uprising on Cona, he did his best to hide innocent men, women, and children left behind during the Empire's purges, and to give them homes and new identities. He escaped to Tatooine, and took over the company from the dying owner. He uses disguise techniques to keep his true identity secret. He aids the Rebellion, no matter how quietly.

Personality: Unut is a quirky old codger, with a heart of gold. He is a gentle persuader and relentless charmer.

Objectives: To remain ignorant of the changing galaxy as long as possible.

A Quote: "There are only three areas of legal commerce — antiques, used vehicles, and real estate — in which prices and terms are set by negotiation. Fixed labels and prices don't mean a thing. So ... how much do you think the speeder is really worth?"

Geordi Hans

Template Type: Young Mechanic

Loyalty: To Unut Poll

Height: 1.6 meters

Species: Human

Sex: Male

Homeworld: Tatooine

Age: 17

DEXTERITY 3D

Blaster 3D+2, dodge 4D

KNOWLEDGE 2D

Streetwise 3D, survival: desert 4D+2

MECHANICAL 4D

Repulsorlift operation 6D

PERCEPTION 2D

Search 3D+1

STRENGTH 3D

TECHNICAL 4D

Computer programming/repair 5D+1, Droid programming 4D+1, Droid repair 5D+2, repulsorlift repair 7D, space transports repair 4D+2

Force Sensitive?: No

Force Points: 3

Dark Side Points: 0

Character Points: 2

Description: Geordi has black hair and alert brown eyes.

Background: Geordi's parents abandoned him when he was six years old. Forced to fend for himself in a rough frontier town, he soon hitched a ride to Mos Eisley. Once there, he quickly learned about growing up. Having been swindled and double-crossed enough times to learn from it, he began tinkering with machines. They, at least, never lied. He spent his formative years repairing speeders and avoiding truant officers. Eventually he met Unut Poll, a kindly Arconan who treated him well. Judging from the way that Unut has been talking lately (about Geordi taking over the business), Geordi fears that he must soon choose between taking over Unut's business or following his own path out among the stars.

Objectives: To get that extra bit of performance out of a vehicle.

A Quote: "Yeah, but see right here? The transcore gear is stripped. I'm afraid we'll have to take this entire engine apart."

Wioslea

Template Type: Vuvria Salesperson

Loyalty: To herself

Height: 1.9 meters

Species: Vuvria

Sex: Female

Homeworld: Unknown

Age: 34

DEXTERITY 2D+1

Dodge 4D+1, pick pocket 3D+2

KNOWLEDGE 3D

Alien species 4D+2, alien species: Humans 6D, business 3D+2, cultures 4D+1, languages 5D+1, languages: Aqualish 6D, languages: Arcona 5D+2, languages: Vregg (Gamorrean dialect) 7D, languages: Hutttese 7D, languages: Rodian 6D+1, languages: Sullustan 7D, planetary systems 4D, streetwise 5D,

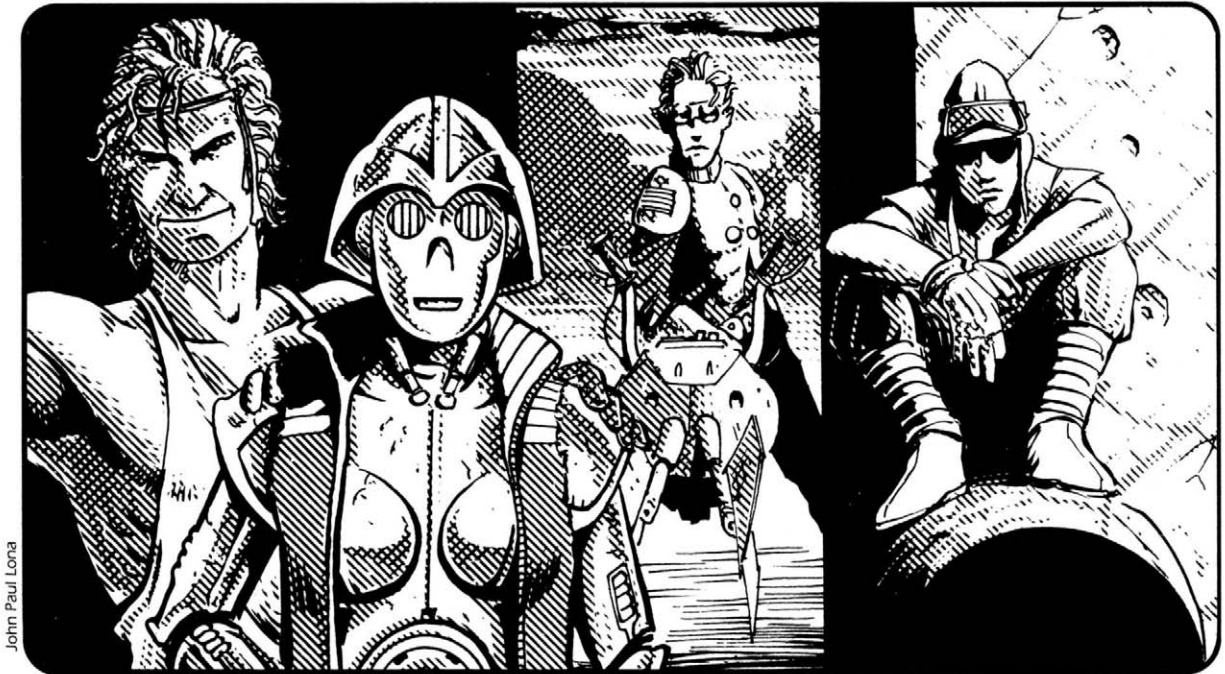

John Paul Loma

streetwise: Tatooine 6D+2, value 4D, value:

landspeeders 6D+2

MECHANICAL 1D+2

Repulsorlift operation 3D

PERCEPTION 3D+1

Bargain 5D, con 4D+2, gambling 4D+2,

persuasion 4D+2

STRENGTH 2D

TECHNICAL 1D

Force Sensitive?: No

Force Points: 0

Dark Side Points: 0

Character Points: 0

Equipment: Long cloak, comlink, datapad, 200 credits

Description: A tall Vuvria, with an almost comical face, Wioslea is a disarming personality: her physical appearance greatly relaxes customers, allowing her to cleverly drive hard bargains.

Background: No one knows where the Vuvria comes from, and she won't talk about it. She had been on Tatooine for a few months before she approached Unut for a job, and she has served well since then. Unfortunately, she has gotten into debt to one of Jabba's con man cronies (for over 1000 credits!), and thus she is quietly spying for the crime lord.

Personality: Friendly, but intensely private. She doesn't tell anyone any more about herself than she has to.

Objectives: To pay off her debts, and then look to relocate to another planet.

Quote: "4,000 credits ... only 4,000. You look like you could use a break, kid. Sold."

The Farns

Geordi Hans, and his buddies, Jeff Pill and Franklin "Shorty" Scott, are the sole members of a "swoop" gang called the Farns. Actually, they are swoop gang wannabes, since only Franklin has a bike, and it is a speeder bike, not a swoop.

The fourth quasi-member of their group is the Droid Ay-BeeSix (A-B6); she can be seen hanging around asking questions and generally getting in the way. The gang puts up with her, mostly because she will do almost anything and go almost anywhere for them.

The group is occasionally thoughtless when it comes to the Droid: Franklin once asked Ay-BeeSix to go into the Mos Eisley Cantina, a known den of thieves, rogues, and brigands, and get a hydrospanner wrench. She came out with one, all right, but was closely followed by its owner, a very angry Gamorrean. Since putting her back together, they've treated her better.

When Second Twilight approaches, they can usually be seen on the outskirts of town, tinkering with Geordi's speeder and Franklin's heavily modified Ikas-Adno Starhawk.

This group is honest and unthreatening — they would rather race than wreak havoc. Their true dream is to escape Mos Eisley, but Jeff is unmotivated, Franklin is scared, and Geordi has realized that Unut Poll has dreams of eventually handing over the shop to him. For now, the locals must remain ready to jump out of the way when the "gang" tears through the streets at First Twilight, trying to beat their own record for getting out of town.



Mike Vilardi

4. Lup's General Store

This establishment is actually named Lup's Wares and Supplies, but most everyone knows it as "Lup's General Store." Kal Lup and her husband Tar run the store, and despite their fierce, wolf-like appearance, they are both friendly and helpful.

The store contains provisions, supplies, and a smattering of machinery. The main display room (about eight by five meters) has the front door on the south wall; opposite it is a row of countertops with barstools, with a monitor at each seat. These are touch-screen activated, allowing the prospective patron to browse the catalog of available merchandise. Out of the fifteen monitors, six are still functioning (one in black and white). There are three metal doors on the wall behind the counter.

Mounted on the left wall is a block of twelve large monitors, advertising the day's specials and the latest merchandise. All of these still work, but the sound fades in and out. Kal has been meaning to fix it but can never find the time.

The first of the doors leads to a large, well-lit bathroom. The mirror above the rinsing station can slide open. Here is where most illegal transactions are conducted between the Lups and their customers.

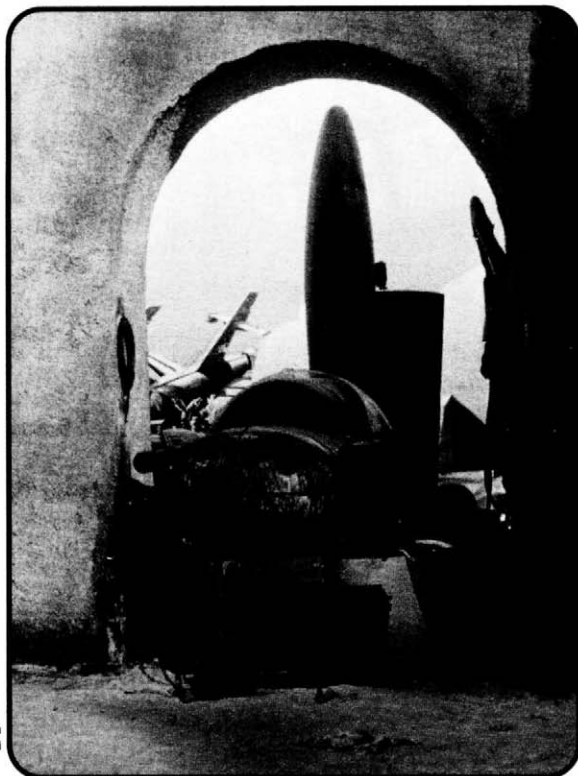

LFL

The second door leads to a pair of rear offices and a meeting room. This is where customers with specific (read: illegal) requests can haggle in private.

The final door is the warehouse access portal, where three Droids pack merchandise for customers.

The Lups charge reasonable prices and stock a good variety of foodstuffs and equipment, charging anywhere from 90 to 110% of the prices listed on page 161 of the *Star Wars: The Roleplaying Game, Second Edition* rulebook; they charge 120% of market value for medical equipment and weaponry. Using the availability codes on page 161 will help establish Mos Eisley as an out-of-the-way hole in the wall: thus, all code one products ("readily available") can be found in the general store, *most* code two products ("large cities and spaceports") are available or can be ordered, but specialized or rare products (codes three and four) simply cannot be had here.

The Lups have been experiencing some trouble with Jabba lately. When business is slow, he still expects the same protection payments, while the Lups would prefer a sum targeted to their weekly gross receipts. In fact, they have demonstrated that the payment amount would actually *increase* under their system when business was good. But Jabba, concerned that the thugs he uses to pick up the payments might find the temptation to start skimming the fluctuating take to be overwhelming, has so far declined the offer.

The Lups are congenial lupines, but tend to remember any slights and perceived rudeness. They do not like anyone poking about in their business. They have an old blaster carbine (4D+2 damage, 3/20/150) hidden behind the counter.

The Lups

Height: 1.8 meters

Species: Shistavanen Wolfman

DEXTERITY 2D+2

Dodge 4D+1

KNOWLEDGE 4D

Business 5D+2, streetwise 6D, value 5D

MECHANICAL 3D

PERCEPTION 2D

Bargain 4D+2

STRENGTH 3D

TECHNICAL 3D+1

Force Sensitive?: No

Force Points: 0

Dark Side Points: 0

Character Points: 1

5. Market Place: Gep's Grill and Spaceport Express

Less a group of established businesses, and more of a Gundark-flea market, Market Place is the spot where free enterprise agro farmers come to sell their produce and fledgling businesses go to start trade.

The area was nothing more than a sandy lot when the farmers began setting up their tents here. Over the years, the market place has thrived, and no one bothers it even though no one has ever secured trade permits or any other official documentation.

The tents mark off territory and provide protection from the searing suns — they have solar energy collectors, which power cooling generators, grill units or any other portable machinery. The tents offer vegetables and meat, harvested from underground agrofarms, or collected from hunters out on the Dune Sea. Some also sell trinkets, inexpensive tools, homespun clothing or other individually crafted or cheap items.

Gep's Grill

A typical stall is the one owned by Fillin Ta and Norun Gep, situated just behind Lup's General Store. Meeting in the same jail cell when they were street urchins, they have since become friends. The two young Whiphids have been making a good living by rendezvousing with hunters on the outskirts of the city and buying Bantha and Dewback meat from them. They do not question the origin of the meat, and have sometimes needed to cut off a brand or two which the careless hunters left on the haunches.

On those off-weeks where the hunters have had no luck, Fillin and Norun have had no misgivings about looting local Bantha and Dewback stables, using pilfering skills they picked up by necessity as children on the streets of Mos Eisley.

Once hauled to the tent and prepared, the Whiphids grill the meat throughout the day. Many local workers stop by during the day to sample their wares. The menu is simple, but adequate for quick meals.

Welcome To Gep's Grill!

TODAY'S SPECIALS

Bantha Burger _____ 1.5c

Bantha Platter _____ 2.0c

(comes with all the fixin's and salamander sticks)

Dewback Ribs (6 pack) _____ 2.5c

Ribs (10 pack) _____ 4.0c

The Whiphids also engage in more than grilling food — old habits die hard, and smuggling is Mos Eisley's business after all. They perform small scale courier runs of weapons, spice and other forms of contraband for various customers. While the boys haven't gotten into trouble yet, they have been quite indiscreet, crossing Jabba without knowing it.

Spaceport Express

Norun has recently allied with one of the local messenger services, Spaceport Express (a branch office is located immediately behind Gep's Grill). For a piece of the action, the messenger service accepts orders and drops them off at the tent. Omon Gantum, the Quarren who runs Spaceport Express, was more than happy to add to his already ample income.

Spaceport Express started off handling only legal goods: jewels, medicine, goods and information. After teaming up with the Whiphids, business has blossomed. Fillin and Norun, while on runs out of town for meat, buy stolen equipment or meat stuffed with contraband — the messenger service handles all inquiries and payments.

In fact, Omon Gantum is being so helpful because he is selling a list of the contraband to Valarian at the Lucky Despot. She reviews the deliveries and occasionally spots something worth looking into. This usually results in her sending a representative to purchase the stolen goods from the ultimate recipient or, less likely, directing a thug to waylay the messenger. So far Fillin and Norun are unaware of the duplicity.



Mike Vilardi

6. Docking Bay 86

Very similar to the now infamous Docking Bay 94, “old 86” is a round pit gouged in the soil. It is slightly smaller in landing space than most other docking bays, and the vast majority of its business consists of small shuttles and personal transports (scout ships and the like).

Old 86 has an absentee owner, Trepler Darklighter, who spends most of his time away on resort worlds (no one knows where he has

gotten his wealth, but since he is a local boy—his family is from Anchorhead—many assume it is from the smuggling trade). The bay is run by an ill tempered administrative Droid named BX-9T. Its humanoid, blue and red form is easily recognized in the spaceport city, and most people know enough not to bother with the Droid unless they have to. Rates for the bay are 35 credits per day.

7. Docking Bay 87

Directly across the street from Docking Bay 86, and within one block’s walk of the famous Mos Eisley Cantina, Docking Bay 87 is among the top ten favorite bays of smugglers and merchants in this city. The bay is of the same age as the others in the central portion of the city, but its owners have continually modernized the facility—currently, the landing bay is at ground level, with a double blast door and forcefield that opens directly into the street. The bay charges 30 credits per day, and restocking and maintenance charges are charged at the same rate as Docking Bay 94. Unofficially, the bay also charges a flat fee of 25 credits to avoid “bureaucratic hassles” (i.e., cargo inspections)—if the pilot in question doesn’t pay the fee, there is a one in three chance that his ship will be searched; if the fee is paid, the ship will not be searched barring very unusual circumstances. Needless to say, a good

portion of that 25 credits is diverted to the customs officials of Mos Eisley.

The bay has a larger landing area than average, enabling it to handle slightly larger ships (and with the size of the bays in Mos Eisley, every square meter counts). The bay is owned by a cheerful Ishi Tib (see *Galaxy Guide 4: Alien Races*) named Dr’xureretue (although he insists that people call him “Drue” since most people can’t pronounce his name). He is easy going, but uncompromising when it comes to fees and business practices; however, he will warn newcomers about how business is done in Mos Eisley, so he is a good source of information and gossip. He has two common labor Droids that unload and load cargo, and Dom Antyll from location 21, “Docking Bay 92” performs any necessary maintenance and repair work.

8. Mos Eisley Inn

This run-down building has the bare necessities and little else. For 10 credits a day (officially; the clerks try to haggle for more and pocket the excess), a customer gets a place to sleep, a shower, and access to public communicators. Those who are willing to pay the extra few credits get the subterranean rooms, which are dark and cramped, but cool; those who are tough bargainers often get stuck with the rooms on the upper floor, which are almost unbearably warm.

The inn has a central lobby with a transparisteel canopy and several imported trees. The clerk is a grumpy Human local, but for those who give a few extra credits he will give extra courtesy. The clerk knows how to get ahold of any number of underworld contacts, and can arrange escorts or any number of other services for additional tips. There are several beat-up servant Droids that are supposed to take luggage to guests’ rooms, but they are seldom functioning.

9. Tatooine Militia

This building houses Mos Eisley's militia, and in recent times, has become the permanent base of any stormtroopers stationed in the city. The militia used to have four full-time members, but they have been transferred to the newly formed police force. Now, however, the militia can call on up to 50 individuals to take up arms and put down Tusken Raider attacks or other potentially dangerous situations. In times of high crisis in the city, militiamen are also asked to perform patrol duties, but the men have been known to actively avoid action if at all possible. If they do become involved, the militiamen are likely just to arrest any visitors and allow the locals to escape punishment — after all, no one wants to arrest their neighbors. As it stands now, the militiamen are seldom called upon for duty.

The building has a large weapons vault (Moderate *security* total to pick the lock; walls and door have a *Strength* of 7D). There are about 25 blast vests, 50 blast helmets, 50 blaster carbines, several dozen grenades, a score of stun batons, spare power packs and three E-web blasters in the vault.

There is always at least one militiaman on guard duty, and he can raise the alarm with his comlink. The militia uses location "10. Dewback Stables" to store its vehicles.

Mos Eisley Militiaman

DEXTERITY 2D

Blaster 4D, dodge 5D, melee combat 3D+2, melee parry 3D+2

KNOWLEDGE 2D

Intimidation 3D

MECHANICAL 2D

Beast riding 3D+1, repulsorlift operation 3D+2

PERCEPTION 2D

STRENGTH 2D

TECHNICAL 2D

Force Sensitive?: No

Force Points: 0

Dark Side Points: 0

Character Points: 0-5

Equipment: Blaster carbine (5D damage, 3-25/50/250), stun baton (5D stun damage), blast vest (+2 to energy, +1D to physical attacks), blast helmet (+2 to energy, +1D to physical attacks), comlink

10. Dewback Stables

Almost as old as the city itself, these dewback stables hark back to a time when people couldn't easily afford repulsorlift vehicles and had to stable their dewbacks and banthas while visiting town. Now, the building has been turned over to Mos Eisley's militia, and new facilities have been installed to allow the building to be used as a garage.

A heavy-duty lock (Difficult *security* total to pick) has been installed on double blast doors (*Strength* 4D+1). Inside, the three armored landspeeders at the militia's disposal have been garaged, with a simple R3 unit providing maintenance on them. The landspeeders are normally used only on maneuvers, which occur four times a year. Most often "maneuvers" are just an elaborate excuse for the militiamen to go womp rat hunting, rather than a military exercise. The militia also has half a dozen patrol scooters, which are used for inner city patrol by both the militia and the police.

With the addition of a full-fledged stormtrooper garrison, they have begun storing their speeder bikes in the garage area, making it fairly cramped.

The R3 began loudly complaining about the lack of proper maintenance space until Prefect Talmont threatened to have its memory wiped and sold off to Jawas.

Armored Landspeeders

Craft: Modified Ikas-Adno Sunrunner zX landspeeder

Type: Armored landspeeder

Scale: Speeder

Skill: Repulsorlift operation: landspeeder

Crew: 1

Passengers: 1, plus gunner

Cover: 1/2

Length: 6.2 meters

Cargo Capacity: 40 kilograms

Altitude Range: Ground level – 2 meters

Cost: 14,950 credits

Maneuverability: 1D

Move: 105; 300 KMH

Body Strength: 2D

Weapons:

Laser Cannon

Fire Arc: Turret

Skill: Vehicle blasters
Fire Control: 2D
Range: 3-25/100/250
Damage: 4D

Patrol Scooters

Craft: Menstar Motors 22 Patrol Scooter
Type: Patrol scooter
Scale: Character
Skill: Repulsorlift operation: patrol scooter
Crew: 1
Passengers: 0
Cover: 1/4

Cargo Capacity: 5 kilograms
Length: 2.1 meters
Altitude Range: Ground level – 4 meters
Cost: 5,420 credits
Maneuverability: 1D+1
Move: 25; 70 KMH
Body Strength: 4D

The patrol scooter is perfect for low-speed, high-visibility patrols through the twisting, narrow streets of the city. They aren't designed for high-speed pursuit against other vehicles, but are perfect for keeping up with suspects fleeing on foot.

11. Regional Government Offices

Tatooine's administration is handled from this cramped building by Prefect Talmont (Governor Aryon is only bothered when absolutely necessary). This office handles land deeds, weapon licenses, Mos Eisley resident IDs (each town issues its own form of ID card), settlement charters, taxation and court appearances (there are two small courtrooms in back corners of the building, and court is held once per week at night).

Prefect Talmont is often in his office, which was once a spacious, if run-down, room. How-

ever, it has become cramped due to a preponderance of datadisks and personal effects. It also has a desk, a computer, several chairs, an overhead fan (which never works) and a pair of lights near the ceiling. The office hasn't been cleaned in several years.

Commonly encountered personnel include three clerks, behind desks and computers, who are responsible for recording all vital information. There are no guards here unless there has been a disturbance of some kind in the city that requires official attention.

12. Power Station

This station provides power to speeders, Droids and other items of machinery. As such, it is a place where merchants, clerks, farmers and others meet and discuss business, politics, the weather (or lack thereof) or anything else that springs to mind. This business is busy in the early morning or late afternoon, as it is a gathering place for the "common" people of Mos Eisley who must work daytime hours. Just by hanging

out for a few minutes, characters are likely to hear a number of different rumors (all with varying degrees of truth). The station is run by an unenthusiastic power Droid named 4-LB who seems to care little for the comings and goings of his customers. A speeder recharge runs about 15 credits; Droids require only 3-4 credits worth of power.

13. Jabba's Townhouse

Jabba the Hutt's influence in the affairs of Tatooine is perhaps felt most at his small, almost humble townhouse, in the heart of Mos Eisley. The Hutt has found it convenient to direct many of his operations through his workers at the townhouse, even if the Bloated One seldom comes

here personally. The townhouse, in addition to a local center of operations, also houses many guests who come to Tatooine to do business with the Hutt. Dwarfed by the Mos Eisley Inn, which stands alongside it, Jabba's Townhouse is a converted blockhouse. It is here that he holds court

for only one week or so per season, and only for those business associates who he feels are worthy of his time.

At first, the building seems to be lacking the kind of security one would expect of a crime lord's building. However, one must also bear in mind that retribution from the Hutt is discouragement enough for criminals.

Jabba employs a dozen servants and two dozen guards here; two or three of the guards are disguised as loiterers and beggars stationed in the narrow alley across the street from Jabba's front door. These guards keep tabs on who comes calling, as well as how long they stay.

All doors are heavily reinforced durasteel (*Strength* 5D), and the walls themselves have been reinforced against explosives (*Strength* 3D). Every portal in the building is covered by security cameras hidden in the doorjamb (which transmit to the monitoring station), along with motion detector "fields," which trip when any-

thing passes through a window or door.

Every room in Jabba's Townhouse is wired for sound. The recordings are often played back for the amusement of the employees, especially ones detailing guests' more private moments.

Typical Guard

DEXTERITY 2D+1

Blaster 4D+2, dodge 3D, melee combat 3D+2, melee parry 3D

KNOWLEDGE 2D

MECHANICAL 1D+2

PERCEPTION 2D

STRENGTH 2D

TECHNICAL 2D

Equipment: Blaster pistol (4D, 3-12/25/50), vibroblade (STR+2D), blast vest (+2 from energy attacks, +1D from physical attacks), comlink

Description: Jabba's guards are Human and alien vermin (as one might expect), but by the time they have completed Jabba's training program, they are *loyal* vermin. They dress in their

own clothing, for a rather motley appearance, but they are impatient and eager for a scrap.

1. Main Entrance: This is the main entrance to the townhouse, and non-employees must always use this entrance. The outside is an intimidating and obviously reinforced blast door, with a sole sensor (just like the one used at the entrance to Jabba's palace, as seen in *Return of the Jedi*).

Inside, the door is attended at all times by four of Jabba's more trusted guards. The main entrance can be operated only from the inside, and only upon a voice command from Jabba or his guards. The audience chamber portal at the end of the corridor can be opened only on electronic command issued from Jabba's power sled.

There is a hidden video sensor along the right wall that leads to Jabba's Monitoring Station.

2. Guest Quarters (4): Each of these rooms is luxuriously appointed (by Tatooine standards, anyway). These serve as rooms for those visiting crime syndicate dignitaries who have earned a personal meeting with the Hutt. Each room has a video communica-

Jabba's Townhouse

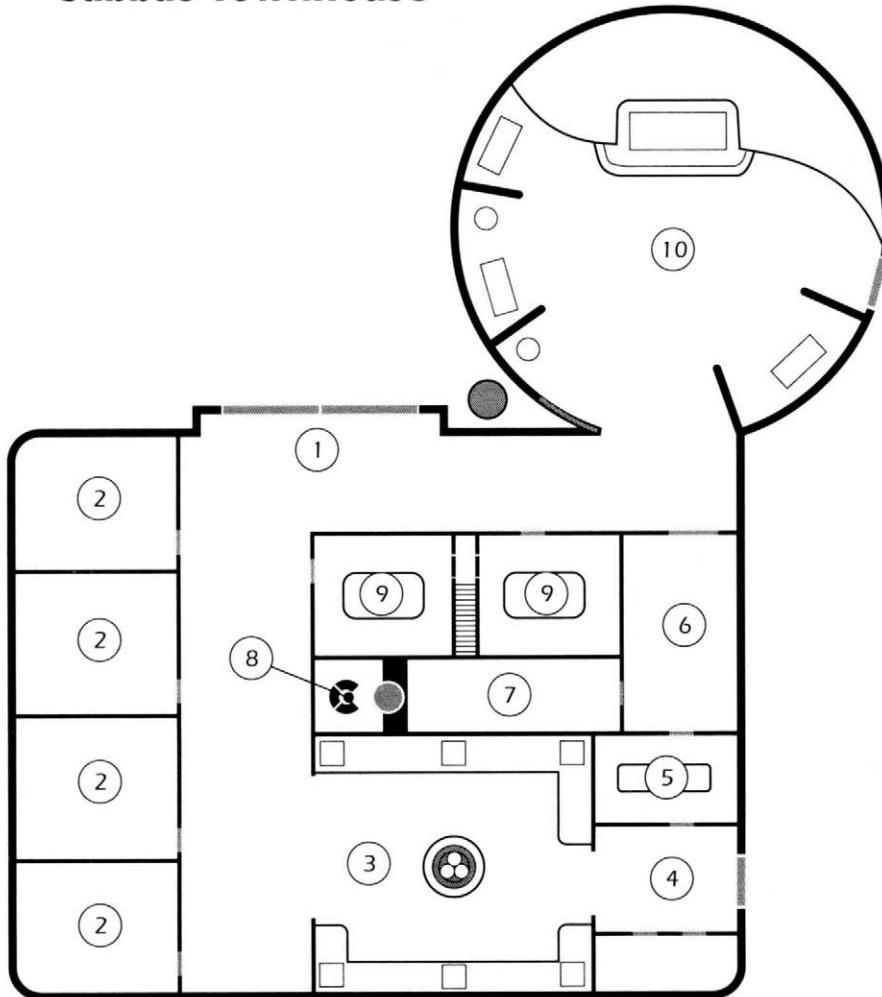





Allen Nunis

tor which has a maximum range of near-orbit (they are bugged, of course), a personal datapad for the guest's use (which copies anything typed into it into a second, permanent storage cell in the basement for later retrieval and examination). Each door has a combination lock (Moderate *security* difficulty to pick).

Jabba has been known to make these suites available from time to time to friends, acquaintances, and those who are in Mos Eisley doing his bidding.

3. Lounge: This is the main recreational area for Jabba's guests and the guards on duty. There are holovids, holochess, and other games of amusement available. This area is off-limits to employees whenever guests are in residence.

4. Employee Entrance And Storage: A sturdy blast door with a combination lock with a Difficult *security* difficulty enters into a hall where

gear can easily be stowed. Armor and weapons are supposed to be left here, but may be locked up for safekeeping, if requested. This entrance is only used by employees.

5. Dining Room: Able to accommodate many beings, the dining room is often an impromptu meeting room and card-playing area.

6. Kitchen: Jabba's tastes are known to be ... *different*. This well-stocked kitchen and its master chef are eager and willing to cater to the Hutt's every whim. From Womp Rat stew to raw Dewback eggs, this kitchen can prepare it.

7. Bathrooms: Clean, with a hidden entrance to the Monitoring Station (Difficult *search* roll to find).

8. Monitoring Station: This station is located in the interior of Jabba's place to provide adequate shielding from outside jamming or other interference (or electronic eavesdropping on Jabba's doings). This room is accessible only from the bathrooms.

9. Conference Room (2): These blast-shielded rooms are soundproofed and ray-shielded. They are also equipped with hidden video sensors (in addition to the standard audio sensors).

These rooms are used to hammer out deals when Jabba isn't present, and is also where the day's take from local merchants is counted. Each conference room has a hidden door (Difficult *search* to find, Moderate *security* total to pick the lock), which opens to a stairwell that leads to the basement vaults.

10. Audience Chamber: When Jabba deigns to visit the city, this is where he resides. The dais was specially constructed to fit his power sled. The room provides enough space for contract negotiation, entertainment (should Jabba desire a performance band) or anything else the Hutt might want. If Jabba isn't here, Bib Fortuna (a Twi'lek), Bidlo Kwerve (a Corellian pirate) or one of Jabba's other lieutenants is often running things, while Akkik the Jawa and Gorrt the Gamorrean are serving as minions.

When Jabba desires private conversations, a pair of heavy blast doors (*Strength* 7D) can be rolled into place, cutting off the rest of the building. The outer door is operated only from Jabba's sled (Very Difficult *security* roll to pick).

Once moored in place, Jabba's sled can function as an elevator, able to descend into the cellar of the building, where he can transact cash deals and oversee prisoner transfers as desired.

The Bloated One also has a sophisticated weapon-detecting Droid stationed in his audience chamber. It serves to warn the Hutt of any firearms, explosives, or other incendiaries which might conceivably be hidden on a being's person, or in a shipment (Droid has *search* at 8D to detect weapons in open view; with exotic infra-

red sensors and the like, it has a *search* of 5D to detect hidden weapons). The Droid has, on occasion, failed to detect more exotic weapons, as well as weapons which seemed to be tools.

A massive wire mesh net is suspended near the domed ceiling, for the use of Jabba's *very* special guests. Roosting there are four Kayven Whistlers (carnivores who resemble a cross between a monkey and a bat and who have voracious appetites). The species is used to nesting high in the tall trees of their native planet of Kayven, and no longer descend to the forest floor. Jabba has used this trait to his advantage.

When the Hutt is displeased, a cage descends to the audience chamber floor, where it is filled. It then rises back up past the mesh, and the door opens. The victim is free to roam along the topside of the wire mesh — it is too narrow to allow a typical Human to drop down through.

The victim remains trapped topside until the Whistlers are hungry, which is usually about twice a week. There is seldom anything to remove after the Whistlers are done feasting.

Although the Whistlers have nowhere near the intimidation capability that Jabba's Rancor is rumored to possess, they are nevertheless effective. Many deals have been negotiated greatly in favor of Jabba because his negotiator became unnerved at the pleas and cries of trapped victims who were awaiting the awakening of the Whistlers.

Kayven Whistler

DEXTERITY 4D

Brawling parry 6D

PERCEPTION 2D

STRENGTH 4D

Brawling 6D

Move: 15

Size: 1 meter long

Attacks:

Razored Teeth: 6D damage.

Jabba the Hutt

Template Type: Hutt Crime Lord

Loyalty: To himself

Size: 3.9 meters long

Species: Hutt

Sex: Male

Homeworld: Nal Hutta

Age: Unknown

DEXTERITY 2D

KNOWLEDGE 3D

Alien species 5D, bureaucracy 7D, bureaucracy: Tatooine government 9D+1, business 6D+1, cultures 4D+2, intimidation 7D, languages 4D, law enforcement 4D+1, law enforcement: Tatooine 9D, streetwise 9D, streetwise: Jabba's organization 11D

MECHANICAL 3D

PERCEPTION 4D

Bargain 8D, command 8D, con 7D+1, gambling 7D+2, persuasion 7D+2

STRENGTH 3D

Brawling 6D, lifting 6D, stamina 7D

TECHNICAL 3D

Special Abilities:

Force Resistance: Hutts have an innate defense against Force-based mind manipulation techniques; they roll double their *Perception* dice to resist such attacks. Hutts cannot learn Force skills.

Force Sensitive?: No

Force Points: 5

Dark Side Points: 6

Character Points: 26

Move: 2

Description: A hairless, bloated slug with quick, snakelike eyes, fetid breath, and a slobbering mouth.

Background: Jabba the Hutt is among the most famous, but not necessarily the most powerful, of the Hutt crime lords. He is credited with forcing the various Hutt crime families to band together to form an unstoppable organization. His pudgy hand is in everything from spice running to extortion to protection rackets stretching halfway across the galaxy.

Personality: Bloodthirsty, ruthless, and altogether foul, with no redeeming qualities.

Objectives: To remain in his position as *numero uno* in the region's crime syndicate.

A Quote: "Bo shudda."

Akkik

Template Type: Jawa Henchman

Loyalty: To Jabba the Hutt

Height: 1.3 meters

Species: Jawa

Sex: Male

Homeworld: Tatooine

Age: Unknown

DEXTERITY 2D

Dodge 4D

KNOWLEDGE 3D

Streetwise 5D

MECHANICAL 4D

PERCEPTION 3D

Con 5D

STRENGTH 2D

TECHNICAL 4D

Droid programming 5D+1

Force Sensitive?: No

Force Points: 0

Dark Side Points: 0

Character Points: 3

Move: 8

Description: Short, smelly, and covered completely by a heavy, hooded cloak.

Background: Mousey, even for a Jawa, Akkik

has always had a reputation for being a nasty little piece of vermin. His exploits in and around Mos Eisley soon earned him the respect of one of Jabba's guards, who took it upon himself to propose that Akkik join the guards. Jabba agreed, and fired him on the spot to make room for Akkik.

Personality: Akkik is covetous, nasty, tricky, a coward, and talks a lot. Nobody can understand him (and Akkik is not his real name, anyway), but that doesn't bother him a bit.

Objectives: To work for Jabba as long as Jabba continues to feed him.

A Quote: "Mop-lou dink dink hee, hee."

Gorrt

Template Type: Gamorrean Goon

Loyalty: To Jabba the Hutt

Height: 1.7 meters

Species: Gamorrean

Sex: Male

Homeworld: Gamorr

Age: 24

DEXTERITY 4D

Melee combat 4D+2, melee combat: vibroaxe 6D

KNOWLEDGE 2D+1

Intimidation 5D+1

MECHANICAL 2D+2

PERCEPTION 2D+1

STRENGTH 4D+1

Brawling 6D+1

TECHNICAL 2D+1

Force Sensitive?: No

Force Points: 0

Dark Side Points: 0

Character Points: 1

Move: 9

Equipment: Vibroaxe (STR+3D+1 damage)

Description: This Gamorrean is green-skinned, with a pig-like snout, small horns and tusks, and powerful muscles.

Background: Gorrt's innate skill as an enforcer was not always recognized out in Jabba's palace beyond the Jundland Wastes. After a brief run-in with an uncooperative store owner, however, Gorrt's "finesse" and skill were rewarded with a permanent post in Mos Eisley.

Personality: Gorrt tends to be protective of Akkik, but generally loves to beat on anything that is smaller than him.

Objectives: To be allowed to beat on other, weaker beings as much as he wants.

A Quote: "Grunt!"

The Hutt also owns the rectangular building behind the Townhouse, which serves both as barracks for his guards and as a garage. It has room for a small sail barge, an assortment of speeders, and posts along the rear to tie up a dozen Dewbacks or Banthas.

14/15. Street Corner Preacher/Wreckage

Mos Eisley was built around the wreckage of the colony ship *Dowager Queen*; what little remains of the ancient ship is still on display in the heart of the city. As the city grew and expanded, the central power and water distribution plant came to be recognized as the heart of the city, but the original blockhouses that stand around the wreckage attest to its age.

As the site of the wreckage is city property, vagrants, hustlers and street preachers of all kinds have taken to staying in the vicinity of the area. Jawas gather shade under the wreckage, con men set up impromptu card trick tables as night and cooler temperatures come, and preachers find a space in the shade of a building and

exhort the benefits of their religion. The most common preachers are Dim-U monks from a distant community called Oasis, who preach that Banthas are nearly divine creatures and that they present a perfect society that the residents of Tatooine should emulate.

Here, in the heart of the old section of the city, there is constant bustle and hustle. Jawas scamper about examining Droids and vehicles, aliens and spacers of all description come and go, and Mos Eisley's residents struggle for daily survival. There are numerous traders who wander through, and if something is going on in the city, people will be in this area discussing the happenings.

16. Mos Eisley Cantina

Located in the heart of the city is the infamous Mos Eisley Cantina. The building hosting the cantina was one of Tatooine's first blockhouses, designed as a shelter against Tusken Raider attacks. The assaults on the city never materialized, and the building became an armory for the local militia. As Mos Eisley grew, the armory was moved, and the cantina went up for sale. Over the years it has undergone extensive modification and numerous owners.

The current owner, a Wookiee named Chalmun, bought the building with gambling profits made while swindling visitors on Ord Mantell. Its central location has been a boon to smugglers, bounty hunters and others with business deals that must be conducted quickly. Now, the cantina is *the* place to meet freighter pilots who handle special cargo — anything contraband or illegal, from weapons, to spice, to Droids is fair game on the Cantina open-market "trading floor."

Wuher, the bartender, is a non-communicative, ill-tempered local but he knows how to keep his mouth shut. The patrons are a fairly boisterous lot who are used to the rough nature of the city; newcomers to the cantina are often given a hard time, but if they return after their initial visit, they are often tolerated.

The cantina has no actual gambling tables (or permits), but there are always a half-dozen card games and other games of chance being played around the room. The cantina pays Jabba the Hutt for protection, and has very little trouble from the crime lord. The cantina is open all day and all night, every day of the year, even during official holidays.

1. Entrance And Droid Detector: Entering from the bright glare of the sands to the elevated entranceway allows the bar patrons to check out the newcomers while they are still adjusting to the dim light. The new Droid detector is up and





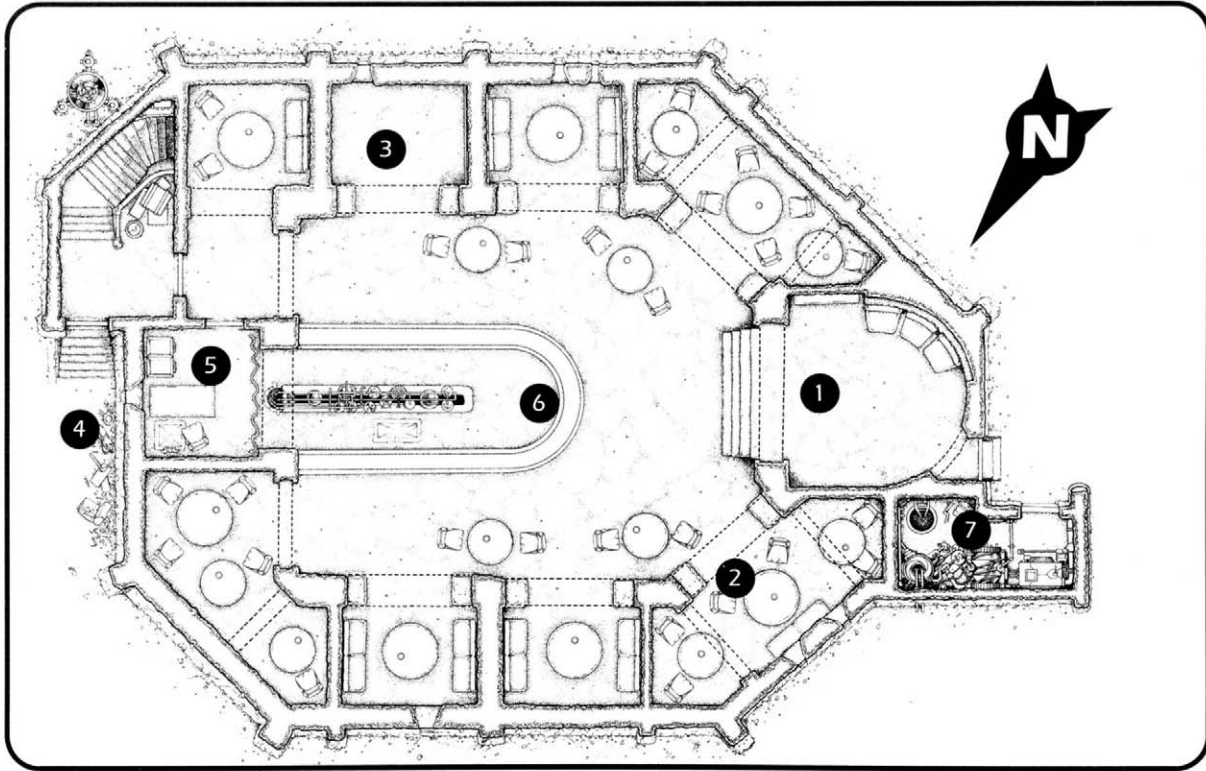

Paul Jequays

running. Chalmun hates Droids, and won't tolerate them in his building.

The couches in this spot are for patrons waiting for rides, although sometimes homeless Jawas make use of them (until they are shooed off).

2. Booth (7): The booths in the cantina vary in size, shape, and capacity, in order to accommodate large groups as well as intimate meetings. To handle the increasingly common overflow crowds, Chalmun added some free-standing tables in the bar area. The booths can handle about 40 patrons; busy times (which can occur any time of day or night) may find over 100 individuals congregating in the cantina.

3. Bandstand: Chalmun, after much coaxing from his employees, decided to add a live band, if only to discourage violence in the bar. He situated the bandstand close to the bar so that the bartender could make sure that the band was earning its keep. Currently, the seven-piece ensemble led by bandmaster Figrin "Fiery Figrin" Da'n is entertaining the natives. The band has just signed another two-season contract with the cantina.

4. Back Hallway: This rear entrance to the bar is left unlocked, allowing those with the knowledge and the need a way to escape. The three restrooms can be found at the bottom of the stairs. The cellar is also where the foodstuffs,

liquor, and ingredients for mixers are kept — in what was once a walk-in freezer. (The door, lock, and walls have a *Strength* of 4D.)

There are at least three ways to get to the basement: the back stairs, the trapdoor in the office, and the access shaft in the power room.

5. Office: Chalmun's office is a small, spartan affair. The office is separated from the bar by both a door and a simple curtained wall. There is a trapdoor here, leading to a ladder that descends to the basement. Chalmun actually keeps his daily receipts in the cellar, in a crate marked "explosives."

6. Bar: The high-tech bar is capable of synthesizing virtually any drink known in this sector of the galaxy. The mixing computer knows 16,000 drinks, but of course the cantina does not stock proper ingredients for all of the variations.

The bar can comfortably handle twenty to thirty beings standing at the bar. It also contains a storage hatch in the floor leading to a shallow compartment, with enough room to hold the bartender's and band's valuables while they are on-duty and performing, respectively.

7. Power Room: The power room holds a cranky Queblux Power Train, which has seen better days. It is wired to the fusion generator in the basement. It powers the lights, climate control, the bar computer, and the mixing machines.



Chalmun

Template Type: Wookiee Bar Owner

Loyalty: To himself

Height: 2.0 meters

Species: Wookiee

Sex: Male

Homeworld: Kashyyyk

Age: 157

DEXTERITY 2D+1

Blaster 3D+1, bowcaster 4D, dodge

3D+2, melee combat 3D

KNOWLEDGE 2D

Bureaucracy 5D, business 3D+2, in-

timidation 6D, streetwise 3D

MECHANICAL 2D

Beast riding 4D+1

PERCEPTION 2D+1

Bargain 4D+1, command 5D

STRENGTH 4D

Brawling 6D

TECHNICAL 1D+1

Special Abilities:

Berserker Rage: +2D to *Strength*. *

Climbing Claws: +2D to *climbing*. *

*See *Star Wars: The Roleplaying Game, Second Edition*, page 137 for more information.

Force Sensitive?: No

Force Points: 2

Dark Side Points: 1

Character Points: 17

Move: 12

Equipment: Bowcaster (4D damage), 200 credits, datapad

Description: A beige and gray-colored Wookiee, Chalmun has a scar which runs diagonally across his left pectoral muscle, beginning at his shoulder and fading out just below his chest.

Background: Chalmun was a street tough as a youth, and quickly learned that his height and weight usually gave him a distinct advantage in a brawl. He also learned that a good blaster can negate that advantage.

The Wookiee has never had much need for saving money, and therefore lived from season to season on the profits from the cantina.

Personality: The way Chalmun treats other beings reminds many people of a slightly dim older brother. He means well, but gets frustrated and often loses his temper. Chalmun is warm to people who can handle his rough affection, but he can also be callous and cruel to those he doesn't know.

Objectives: Continue on the quiet path toward retirement.

Quote: (translated) "I don't care who those guys are. Kick them out; last time they were here, they roughed up some of my regulars."

Cantina Regulars

Vareth

DEXTERITY 2D

Blaster 3D+2, dodge 5D

KNOWLEDGE 3D

Alien species 4D+1, languages 4D

MECHANICAL 3D

Astrogation 4D+1, communications 4D,

space transports 4D

PERCEPTION 3D

Con 5D+2, search 4D

STRENGTH 3D

TECHNICAL 2D+1

Droid programming 5D

Force Sensitive?: No

Force Points: 3

Dark Side Points: 0

Character Points: 11

Move: 10

Garron

DEXTERITY 3D

Blaster 4D+1, dodge 3D+2

KNOWLEDGE 2D

MECHANICAL 3D

Astrogation 4D+1, starship gunnery 3D+1,

space transports 4D

PERCEPTION 3D

Bargain 7D

STRENGTH 2D

TECHNICAL 2D

Computer programming/repair 4D+1

Force Sensitive?: No

Force Points: 2

Dark Side Points: 0

Character Points: 9

Move: 8

Description: Vareth is a slender Human, in her early twenties. Garron is a Sullustan who won't reveal his age.

Background: Vareth and Garron have been buddies for years, ever since they met in piloting school. Garron's unique sense of humor, and Vareth's wise-beyond-her-years knowledge quickly made them an inseparable team.

When Garron's parents died in a shuttle crash,

Sinthia Pulchatt

Species: Kibnon

DEXTERITY 5D

Blaster 6D+1, dodge 5D+2

KNOWLEDGE 2D+1

Planetary systems 4D, streetwise 3D+2

MECHANICAL 3D

Astrogation 4D+1, starfighter piloting 4D+2

PERCEPTION 3D

Bargain 4D+1, gambling 5D

STRENGTH 1D

Climbing/jumping 4D

TECHNICAL 3D+1

Force Sensitive?: No

Force Points: 0

Dark Side Points: 1

Character Points: 9

Move: 11

Description: A 2.8-meter-tall insectoid, Sinthia Pulchatt is a member of the species known as Kibnon, a distant relative of the Verpine. Kibnon are green in

color, and look similar to a Praying Mantis, with bulbous eyes atop a slender stalk. Their four legs aid in stability to support their slender thorax and abdomen. Their arms are usually held up close to their bodies.

Background: Sinthia Pulchatt is one of many Mos Eisley “spice merchants.” Pulchatt was preened for this position at an early age, and fulfills her duties without question; she is a liaison between Jabba, and her boss, whose name she won’t reveal.

Personality: Pulchatt projects a kind and lofty attitude. She is exotic-looking enough to parlay that trait into a conversation starter; however, she is also looking for new spice customers, regardless of the harm the spice will do.

Objectives: To become rich.

A Quote: “Here, try some. It’s only a little — it can’t hurt you.”

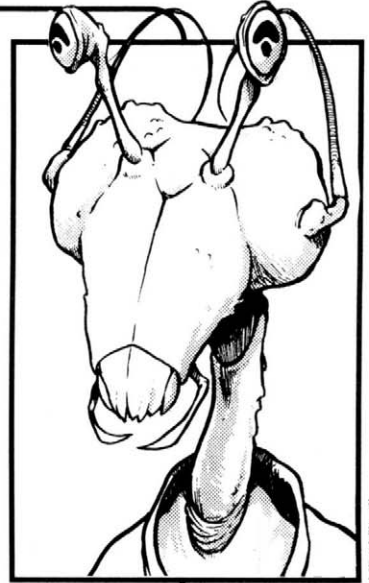

Mike Vilardi

Oxbel

Species: Devaronian

DEXTERITY 2D+1

Dodge 4D

KNOWLEDGE 3D

Streetwise 3D+2

MECHANICAL 2D

Beast riding 4D+1

PERCEPTION 4D

Bargain 6D+1, con 4D+2, gambling 5D+1

STRENGTH 2D

TECHNICAL 3D

Force Sensitive?: No

Force Points: 0

Dark Side Points: 0

Character Points: 4

Move: 9

Description: Oxbel looks the part of a typical Devaronian: a humanoid with razor-sharp teeth and a pair of horns.

Background: Oxbel is the brother of Labria, a Devaronian who used to work for Slag Flats. Like his brother, Oxbel arrived on Tatooine with the intention of a holiday of gambling and having a

good time. Also like his brother, Oxbel has yet to leave.

Oxbel makes his living keeping his eyes and ears open to news, and selling that news to whomever would most like to hear it. His favorite spots are outside Docking Bay 94 and, more likely, either the Lucky Despot or the cantina.

However, Oxbel lacks the talent and ambition of Labria: he spends more time downing lum than poking around for information. If anyone asks, Oxbel is more than happy to explain, through slurred speech, that he is forced to drink from time to time to keep up his disguise.

Personality: When he drinks (which is now a daily habit) Oxbel becomes alternately morose and chatty. He babbles incoherently about both public and private information.

Objectives: Keep selling information so he can afford to drink.

A Quote: “Damnable Gamorreans. Can’t trust ’em. Hey! Spare a credit? I’ll let you in on some information.”



Mike Vilardi



Beeyon Nace

DEXTERITY 3D+1

Blaster 4D+2, dodge 3D+2

KNOWLEDGE 3D

Bureaucracy 5D+2, languages 4D, streetwise 3D+2

MECHANICAL 3D

Astrogation 4D, repulsorlift operation 3D

PERCEPTION 3D+1

Bargain 3D, gambling 4D+1

STRENGTH 2D

TECHNICAL 3D

Computer programming/repair 5D

Force Sensitive?: No

Force Points: 0

Dark Side Points: 0

Character Points: 4

Move: 10

Description: A heavy man of medium height and pale complexion. He is often wearing dark clothing of high society cut.

Background: Beeyon Nace was a promising logistics clerk on Coruscant. One little indiscretion with the

daughter of a ruling governor, and he was sent packing.

His latest assignment is here on Tatooine, working for the Prefect, counting the freighters that come and go. The data is recorded in the spaceport control tower.

His resentment is growing and his patience is wearing thin. If plied properly, such as enabling him to either get off-planet or to be transferred to a new assignment (or to a private company), he might just offer his extensive knowledge of the Imperial bureaucracy. Beeyon can usually be found lurking in the back of the cantina, nursing a drink in an otherwise empty booth.

Personality: Beeyon is perpetually depressed.

Objectives: To lose himself in drink.

A Quote: "It wasn't so bad that I got caught, but the fact that all I got to do was kiss her really bothers me."

he poured the insurance money into a freighter, the *Startled Circuit*. They borrowed the remainder of what they needed to overhaul and refit the ship, and were soon outward bound. The duo are currently on Mos Eisley, looking for work. If the characters are in need of a ship, Vareth and Garron are available.

Objectives: To pay off the loan they got in order to start their shipping business.

Personality: Vareth is a practical young woman, with a great deal of trust and pride in Garron. Garron is expressive, a typical Sullustan trait, but can sometimes become morose over his recent loss.

A Quote: "Sure, we can take you just about anywhere you want to go — as long as the price is right. Trust us."

17. Jawa Traders

Many consider Jawa Traders to be merely a more sophisticated version of a Jawa Sandcrawler: Jawa Traders repairs and maintains their Droids, but sandcrawlers make house calls.

Traders is now owned and managed by a Jawa going by the name of Aguilae, who bought it out from another group of Jawas. Aguilae is not her real name, but it is a convenience for those who can barely manage Basic, much less the Jawa language. Aguilae is a scavenger who displays all the worst Jawa traits. She is filthy, ill-tempered, suspicious, and miserly. She employs only mechanicals because she doesn't trust organics. Due to her carelessness and lack of concern, Droid accidents are commonplace in the facility.

However, Aguilae had a problem. As a Jawa, a technology hoarder by nature, she found it more

and more difficult to actually part with her Droid stock. As she found herself incapable of parting with the machines, she contacted the Squib Mace Windu, who is now a minority stock holder in Traders. Windu owed her money, and in exchange for her forgiving the remainder of his debt, Mace paid into the company half of what he owed her. In addition, he agreed to help run the place for three-quarters of a season for the first three years, with the remainder of time to do with as he wished. For the next three years, he would only have to help out for half a season. He will be free and clear after the full six-year period.

As a Squib, Mace would have liked a more complicated arrangement, but Aguilae would compromise only so far. Squibs hold few things as sacred as bargaining. Reproduction, explora-

tion, conquest, and acquisition pale in comparison to the Squib haggling instinct. Telling a Squib that he is a good bargainer is the greatest compliment possible.

Business has picked up, but the money situation isn't necessarily better. Aguilae is still a collector by nature, and Mace has his own peculiarities: his deals do not necessarily include the exchange of credits.

Aguilae has been careful to steer him firmly in that direction after catching him completing a deal in which he offered a buyer from the Dim-U Monastery a protocol Droid if she would pay half the listed price in credits, and throw in her bosses' old Cloud Car. Aguilae had to spell out to Mace that creditors normally want cash, not Cloud Cars which no longer function. Mace defended himself by explaining that he was going to have Spaceport Speeders fix the Cloud Car in exchange for buying it at three-fourths the going rate. That way, Mace would get the same profit as he would if he had voluntarily allowed himself to be bargained down to 80% of the Droid's list price. Aguilae simply shook her head in disbelief and went in the back to count her Droids.

Since that day Mace has tried to adhere to Aguilae's policies. He feels guilty for misleading her about the simplicity of recent deals, which, despite his best efforts at restraint, are becoming more and more complex.

On the business side of things, Traders has struck up a profitable relationship lately with Doctor Cornelius and his Cutting Edge clinic. The doctor's requests are always for Droid parts, and always very specific. Aguilae doesn't want to know what the parts are being used for.

Mace Windu

Species: Squib
Height: 1 meter
DEXTERITY 4D
 Dodge 5D
KNOWLEDGE 3D
 Alien species 4D+1, cultures 5D, languages 4D, value 6D+2
MECHANICAL 3D
 Astrogation 4D+1, capital ship gunnery 3D+2
PERCEPTION 4D
 Bargain 7D, con 5D+2, search 4D
STRENGTH 2D
TECHNICAL 2D
 Computer programming/repair 5D
Force Sensitive?: No
Force Points: 1
Dark Side Points: 0
Character Points: 8
Move: 10

Description: A tiny, gray-furred biped with tufted ears. He wears a small cap adorned with tiny bits of metal serving no practical purpose.

Background: Mace has been across the galaxy, and is a wealth of useless trivia and misremembered facts on the multitude of species and planets in the galaxy. Mace agreed to help Aguilae run her Droid shop because he owed her money. He is loving every minute of it and is considering opening his own shop, but has no idea what to deal in.

Personality: Mace seems to be an airhead. Actually he is a shrewd Squib, transacting business and judging the importance of things according to Squib values — the love of bargaining.

Objectives: To honor the Squib tradition by achieving the most convoluted bargains possible.

A Quote: "No deal. Try that again, and I'll be on you like a Squib at a two-for-one sale."

Aguilae

Species: Jawa
Height: .9 meters
DEXTERITY 2D
 Blaster 3D+1, dodge 4D
KNOWLEDGE 2D
 Languages 3D, streetwise 3D+2, value 4D+1
MECHANICAL 3D
 Ground vehicle operation: sandcrawlers 5D
PERCEPTION 1D
 Bargain 4D+2, con 4D+1
STRENGTH 1D
TECHNICAL 3D
 Computer programming/repair 5D, Droid programming 6D+1, Droid repair 6D
Force Sensitive?: No
Force Points: 0
Dark Side Points: 0
Character Points: 6
Move: 6

Description: Aquilae is a typical Jawa, with a brown hooded cloak and an aversion to bathing.

Background: When Aguilae acquired Jawa Traders, she had no idea how much it would occupy her life. Her fondness for Droids quickly became an obsession, and Mace Windu was the closest she could come to finding a reliable business partner.

Personality: Aguilae is extremely suspicious of non-mechanicals.

Objectives: To remain around Droids and other high-tech machines.

A Quote: (translated) "I guarantee that this Droid is in good working order and of worth as I represent it."

Droids For Sale

Jawa Traders has a number of vehicle and starship repair Droids simply because that is what the local market demands.

These Droids are not types, but specific, individual Droids; as such, they often have higher skill levels or better equipment than stock Droids

would have. Note that skill bonuses listed due to equipment are in addition to the skill values listed under each attribute. All Droids come complete with a restraining bolt and hand controller.

R4-M17

Model: Industrial Automaton R4 Agromech Droid

Height: 1 meter

Price: 750 credits (used)

Move: 5

DEXTERITY 1D

KNOWLEDGE 1D

Business 2D, business: agriculture 5D+1,

languages: computer languages 4D+2,

languages: Droid languages 4D

MECHANICAL 2D

Machinery operation 5D+1, repulsorlift operation 3D+1

PERCEPTION 2D

STRENGTH 2D

TECHNICAL 3D

Computer programming/repair 4D+2, machinery repair 5D, machinery repair: moisture vaporators 6D+2, repulsorlift repair 4D

Equipped With:

- Three wheeled legs
- Video sensor
- Two fine manipulation arms (+1D to repair skills)
- Arc welder (3D damage, +1D to repair skills)
- Video display screen
- Cybot acoustic signaller (Droid and computer languages)

Despite the R series of Droids having a deserved reputation for co-piloting small space craft, aftermarket engineers discovered that the R4 series were quite suitable for numerous repair operations. Almost identical to the R5 astromechs, the R4 series sports the Intellex III computer, capable of handling both Imperial Navy and Corporate Sector Standard transmission modes, although not as versatile as the Intellex IV in most R2 Droids. Its pair of fine manipulation arms allows the R4 to perform intricate maintenance or repair work, at the cost of flashier equipment such as an R2's holographic projector.

This particular Droid, R4-M17, has seen better days. Its arc welder has an intermittent short (on a *mishap* result, the welder further damages the subject of an attempted repair, increasing the difficulty of subsequent repair attempts), and its third leg can no longer retract. Despite these flaws, R4-M17 would excel in a mechanic shop or farming community.

R4-M17 is a quiet worker. She is stubborn when it comes to completing her assignments, and can sometimes be found in the middle of her

off-duty time finishing up a job that her owner has told her to abandon. She is also rather quiet for a Droid, content to let her work speak for her.

EG-67

Model: Veril Line Systems EG-6 Power Droid

Height: 1.1 meters

Move: 3

Cost: 4,000 credits (rebuilt)

DEXTERITY 1D

KNOWLEDGE 2D

Languages: Droid languages 4D

MECHANICAL 1D

Energize power cells 5D+2

PERCEPTION 1D

Search 4D+2

STRENGTH 1D

TECHNICAL 3D

Capital ship repair 4D, machinery repair 5D, repulsorlift repair 4D+1, space transports repair 4D, starfighter repair 4D+2, systems diagnosis 5D

Equipped With:

- Video sensor
- Bipedal locomotion
- Ultra-fine manipulation arm (+1D *Technical* skills)
- System diagnosis package, including infra-red receptor, sonar, X-ray, and spectrometer equipment (+1D to *systems diagnosis*)
- Cybot acoustic signaller (Droid and computer languages; Droid may not speak Basic or other common languages)
- Armored housing (+2D to *Strength*)

Power Droids, as a subject, evoke remarkably limited interest. Many people consider power Droids to be simple mobile fusion generators, but the latest EG-6 is far more than that.

In addition to fueling equipment and vehicles when power grids are unavailable, the EG-6 analyzes all power components and runs diagnostics associated with the equipment it is servicing. EG-6's sophisticated sensing equipment can detect flaws and wear long before routine maintenance checks normally pick them up. This helps reduce the number of potential breakdowns and dangerous explosions, as the EG-6 will not proceed with refueling if the equipment falls outside of preprogrammed tolerance values. This programming has bestowed upon the EG-6 an undeserved reputation for stubbornness, but it is in the interest of safety.

EG-67 is rather cranky for a Droid. His memory has been wiped quite a few times, usually haphazardly. This means he remembers snippets and pieces of former events and owners, but not enough to get a cohesive feel for his past duties; as a result, EG-67 tends to embellish and interweave these few scraps of memories into stories. Since his acoustic signaller is limited to complex

Droid languages (and not Basic or other common languages), he is only capable of relating his stories to other Droids — many of which have no interest in the fanciful tales.

WED15-D3

Model: Cybot Galactica WED15 Treadwell

Height: 1.6 meters

Move: 8

Cost: 650 (used)

DEXTERITY 2D

KNOWLEDGE 1D

Languages: Droid languages 4D

MECHANICAL 1D

PERCEPTION 3D

Search 3D+1

STRENGTH 1D

TECHNICAL 2D

Computer programming/repair 4D+2, machinery repair 6D, repulsorlift repair 4D, space transport repair 4D+1, starfighter repair 5D+1

Equipped With:

- Video sensor
- Dual-tread locomotion
- Fine manipulation arms (+1D to repair skills)
- Extensible video microbinoculars (+2D to search for microscale work)
- Various tools
- Cybot acoustic signaller (Droid languages)

One of the first commercially successful uses of treads for Droid locomotion was in the aptly

named Treadwell model. The Cybot Galactica company managed to overcome the pitfalls in earlier tread designs by using a pair of heavy-duty treads powered and steered by a set of ten wheels, along with a chassis with a low center of gravity (avoiding the problem of top-heavy Droids being unable to right themselves after a fall).

The WED15 has been deemed “flighty,” but its capabilities outweigh the personality. WED15’s can be found almost anywhere on Tatooine’s surface, repairing and maintaining all forms of equipment with microbinoculars that are un-

Droid Key

1. Roche J9 Worker Droid
2. Arakyd BT-16 Perimeter Droid
3. Demolition Droid
4. R4 Agromech Droid
5. WED15 Treadwell Droid
6. EG-6 Power Droid

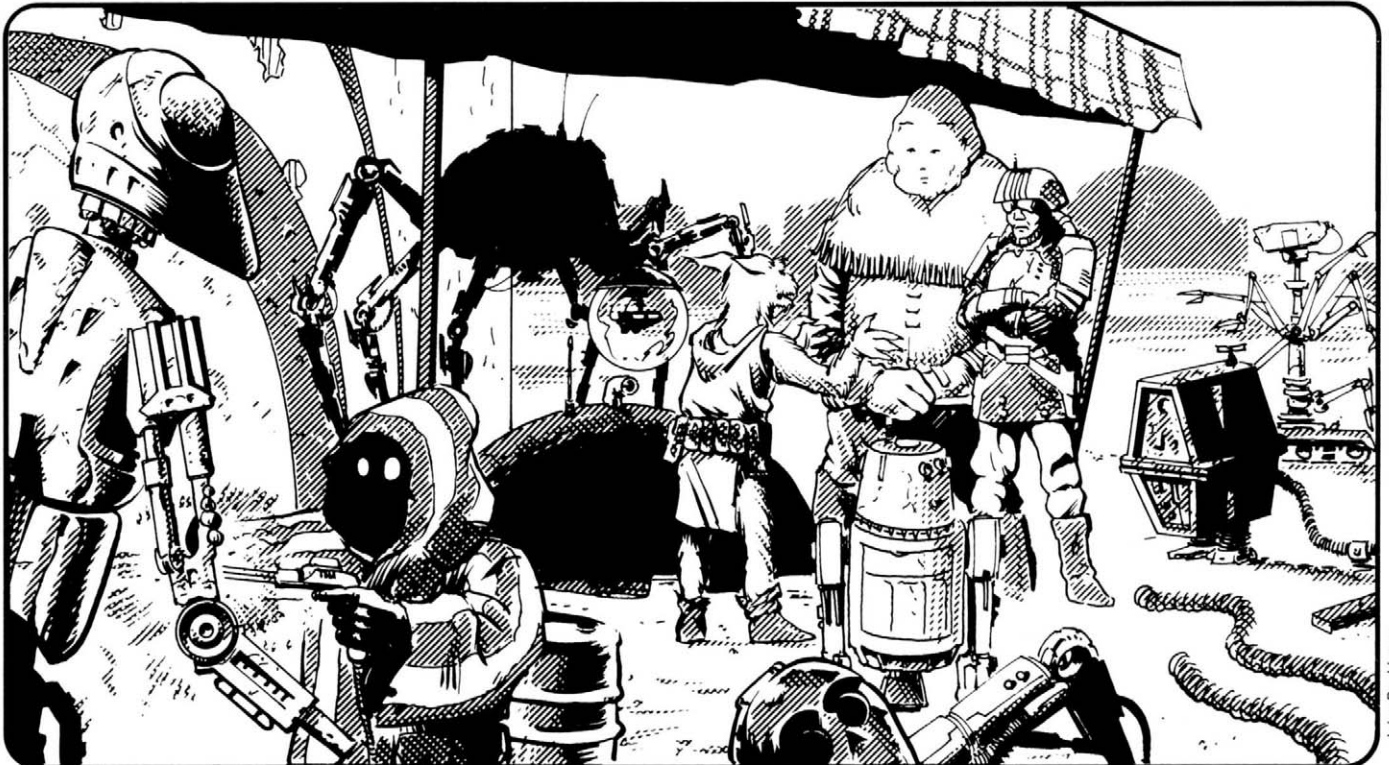
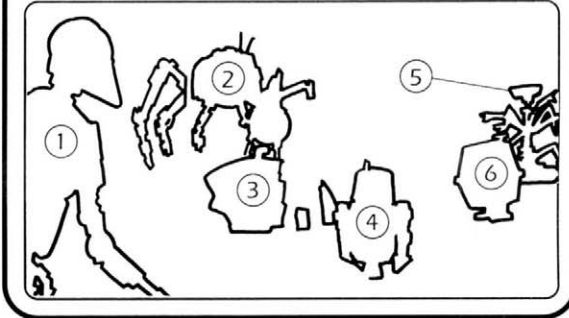

John Paul Lona

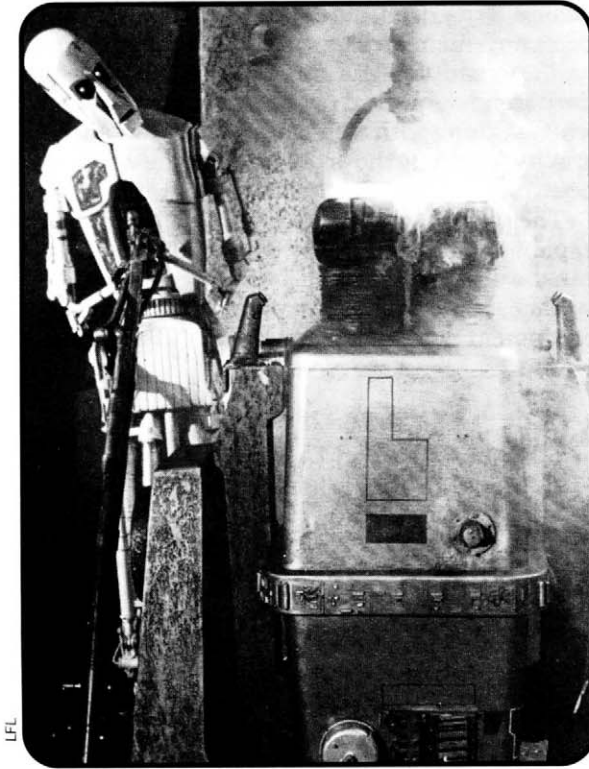

matched in their capability to view fine detail. The Droid has a six-arm capacity along its single stalk, but most come equipped with four to five of varying strengths and elegance.

However, the arms are delicate, and they continually get caught in machinery as the WED15 passes by, obviously hard at work repairing this or that. Replacement arms tend to be of lower quality. Its vocabulator is restricted to binary languages.

This particular Droid, WED15-D3, is capable of repairing virtually any vehicle or piece of machinery. WED15-D3 is a suspicious Droid. Maltreated and ostracized since first being placed in a job, it resents its perceived flighty personality and takes great pains (usually unsuccessfully) to counter the impulses which have been programmed into it.

LIN-D2D

Model: Cybot Galactica LIN Demolitionmech Mining Droid

Height: 0.7 meters

Move: 3

Cost: 800 (used)

DEXTERITY 1D

Blaster artillery 4D

KNOWLEDGE 1D

Languages 2D

MECHANICAL 1D

PERCEPTION 3D

Gambling 5D+1

STRENGTH 6D

TECHNICAL 3D

Demolition 6D+1

Equipped With:

- Video sensor
- Dual-tread locomotion
- Fine manipulator arm under dome (for planting explosives)
- Cybot acoustic signaller (can only speak Droid languages).
- Armored Housing (+2D to *Strength*)

The LIN Droid chassis is based upon the familiar Cybot Galactica Treadwell design, but with a high density, reinforced durasteel dome. The awkward slowness of this mining Droid was a design tradeoff: in exchange for an almost-impenetrable armor shield, the Droid could plant mining explosives in the most dangerous caverns without concern for falling debris or corrosive soil.

Alas, the LINs were prone to breakdowns resulting from the incredible moisture levels commonly encountered in caverns and caves. When a charge a LIN was holding went off prematurely, causing a cave-in and the loss of ten miners, the Droids were pulled off the market.

LINs can now be found scattered around a thousand worlds, performing tasks far beyond their original programming. This specific Droid, LIN-D2D, was first reprogrammed to serve as a data recorder for legal cases. Her second job was as a mobile entertainment system in a shipboard casino. Fitted with theatrical lasers, prerecorded music, and a level surface on top of the dome, she would synchronize a light show with music as she served drinks. And, using specially-equipped gambling tables, she would plug into the table's computer terminal and gamble with patrons.

LIN-D2D is currently programmed for use as a forward military observer. Her installed programming module is capable of linking up to common combat artillery. The Droid was due for a memory wipe, but this was forgotten in the panicky shuffle to sell it off before the lieutenant who devised this unauthorized experiment was demoted (or worse). LIN-D2D is reticent about revealing this aspect of her past, and instead discusses her previous experience as an entertainer. Not surprisingly, after five seasons she remains unsold.

J9-6

Model: Roche J9 Worker Drone

Height: 1.9 meters

Move: 10

Price: 1,100 (used)

DEXTERITY 2D

KNOWLEDGE 4D

Alien species 5D+1, bureaucracy 5D+2, languages 4D+1

MECHANICAL 1D

PERCEPTION 3D

Bargain 4D+2, sneak 4D

STRENGTH 2D

TECHNICAL 3D

Security 5D+1

Equipped With:

- Video sensor
- Bipedal locomotion
- Olfactory sensor (+1D to odor-based search)
- Torplex microwave sensor (+1D to security)
- Arjan vocabulator
- TranLang II Communication module (+2D to languages).

The Verpine, a highly evolved insectoid species, developed this remarkable unit. Named for the secondary species of the Verpine, the J9 Worker Drone embodies many of the qualities of the popular 3PO-series protocol Droid.

The J9 is equipped with a TranLang II Communication module, making it possible to understand over a million different languages. Its Arjan II computer is roughly equivalent in capacity to Cybot Galactica's AA-1 VerboBrain.

The major difference between a protocol Droid and a Worker Drone is appearance. J9 Droids have insectoid eyes, and piston-like limbs. Their legs are even more awkwardly-jointed than a protocol Droid. If potential purchasers could get over the outer shape of the Droid, they would see that it performs almost as well, at two-thirds the price of, Cybot Galactica's offerings.

Worker Drones are notoriously busy, although their ability to *complete* a job is sometimes in question. This Droid, J9-6, has seen his share of duty. He has developed a hyperactive twitch in his neck servomotors, which causes him to turn his head back and forth, as if alternating between one insectoid eye and then the other.

LBT-16

Model: Arakyd BT-16 Perimeter Security Droid

Height: 2.3 meters

Weight: 75 kilograms

Move: 14

Cost: 3,100 (refurbished)

DEXTERITY 4D

Blaster 5D+1, dodge 5D+1, grenade 5D+1

KNOWLEDGE 2D

Languages 3D+1, law enforcement 4D+2, survival 3D+1

MECHANICAL 1D

PERCEPTION 4D

Search 4D+1

STRENGTH 1D

Climbing 2D+1, swimming 2D+1

TECHNICAL 2D

Computer programming/repair 3D+2, security 3D+1

Equipped With:

- Video sensor
- Six-leg locomotion
- Sensor package: Carbanti motion sensor, fabritech seismic sensor (+1D to search)
- Imperial standard comlink
- Arakyd vocabulator (speaks Droid languages only)
- TranLang I Communication module (+1D to understand languages)
- Armor (+2D to Strength)
- Taim & Bak Repeating Blaster
Fire Arc: turret
Range: 2-10/25/50
Damage: 6D

The BT-16 perimeter Droid is a reliable model, based on an arachnid design that has long been in service. Its six legs support the abdomen of the Droid in which most of the Droid's sensor controls are located, giving it far superior speed than a bipedal Droid design. It is capable of sensing almost any type of disturbance imaginable: its multiple sensors can even detect small animals burrowing in the soil underneath it.

LBT-16, when it arrived at Jawa Traders, was a psychological mess. While in excellent physical shape, the Droid needed a complete memory wipe to overcome whatever traumatic experience it had been through.

18. Heff's Souvenirs

This store is, to put it bluntly, a junk shop. The shop offers an odd collection of old bannisters, ancient Hologrid players, cracked hallway mirrors, decrepit baby cribs, and other assorted things which are of no real value to anyone except as curiosities. Behind the counter is a collection of unique souvenirs depicting local Tatooine sites. One is a glass bubble under which a water-filled diorama depicts the Jundland Wastes; if shaken, crystalline shards are stirred up to mimic a sandstorm. Another is a collection of purplish rock chips fused together, with the words "Mos Eisley"

drawn in glue and covered in sand. Yet another item is a tiny shard of pourstone, with a painting of the Mos Eisley cityscape. The outstanding offering is a mounted, glazed Womp Rat. Other knick-knacks exhibit the same lack of taste.

Of course, Tatooine's tourist trade is so small that no souvenir shop, especially with this caliber of merchandise, could make a profit. The new owner, Moplin (he bought the shop from Tebbi, Heff's daughter, after Heff was killed in an unfortunate incident involving bounty hunters a few seasons ago), makes his living not from the shop,



Mike Vilardi

Moplin Jarron

Species: Sullustan

Sex: Male

Height: 1.4 meters

DEXTERITY 2D

KNOWLEDGE 4D

Bureaucracy 4D+1, bureaucracy: Tatooine

5D+2, business 6D, languages 4D+1, law

enforcement 6D

MECHANICAL 1D

PERCEPTION 3D

Bargain 4D+1, forgery 9D+2

STRENGTH 2D

TECHNICAL 3D

Computer programming/repair 5D, Droid

programming 5D+2, security 4D+1

Force Sensitive?: No

Force Points: 0

Dark Side Points: 0

Character Points: 8

Move: 9

Description: Moplin is a middle-aged Sullustan (indicated by extreme wrinkles around the eyes), with an apparent distaste for cleanliness.

Background: Moplin became skilled in forgery after a short stint in a prison colony for a "slight misunderstanding." The food rationing system forced him to come up with a skill with which he could barter with the other inmates for food.

Personality: Moplin is a nervous little being, with a perpetual squint and hunched back. He laughs a lot, for no apparent reason.

Objectives: Remain indispensable in Mos Eisley so that he can continue to indulge in "antiques."

A Quote: "Well (hee), yes. I can do the job. Only a hundred credits."

but through his forgery abilities. The old Sullustan can forge false Tatooine township ID's for 100 credits, false Tatooine passports for a minimum of 200 — docucards for other worlds are correspondingly more expensive because of the more difficult nature of getting a good forgery. Such forgeries normally require at least a full day's notice. Prices and times can fluctuate based on local demand, availability of suitable materials and other factors, so the prices above are merely general guidelines.

19. Kayson's Weapon Shop

Kayson's store has been in business for many decades, providing personal armaments to farmers, street thugs and anyone else with good credits. Kayson is a grizzled alien with atrocious manners and a seemingly sour disposition. His greatest asset is his ability to keep his thoughts to himself when dealing with customers.

The shop is typical Tatooine construction. The interior walls are literally covered in new, used, ancient and modern weapons (all are kept empty and unloaded). Almost anything of a personal nature can be found, but heavy artillery is unavailable.

Kayson knows his weapons, and maintains them well. His reverence for them shows in the care and handling they receive. Because of the

quality of his equipment, most everyone shops here. It is not unusual to see off-duty police examining the wares.

Kayson attempts to maintain the appearance of a reputable business; however, his skills at acquiring contraband weapons, especially on this isolated backwater, are exceptional. Black market weapons have obscured identification plates, and customers can avoid officially registering them with local officials.

Item	Cost
Heavy Blaster Pistol	1,500
Blaster Rifle	2,000
Light Repeating Blaster	4,000
Heavy Repeating Blaster	6,000
Thermal Detonator	4,000

20. Docksider Cafe

This building, adjacent to Docking Bay 92, is a small restaurant and bar that hosts numerous spacers. Like the Mos Eisley Cantina, it is a popular meeting place for those who need to hire smugglers for unsavory business. While the Cantina generally attracts the most talented individuals, those who are newer to the business (and thus, eager to take on more dangerous missions for lower fees) are known to frequent this location.

The cafe is dimly lit, with many alcoves and booths for private conversation. There is no gambling to be had here, but there is a live band and several very attractive waitresses (always a morale boost for tired spacers). The bartender is a pokey, bitter Droid named CG-X2R; however, the Droid seems to take no notice of what happens, so most spacers are more than happy to tolerate the complaining.

21. Docking Bay 92

This docking bay is owned by Dom Antyll, one of the best starship mechanics in all of Mos Eisley. In fact, this bay is used almost exclusively for starship repairs, and in its underground rooms are all manner of starship repair tools, labor and engineering Droids and other items that Dom might need (Dom has a distrust of most organics and prefers to rely on Droid labor for assistance). Dom charges about 125% of what "average" mechanics charge, but his work is first-class and guaranteed.

Dom Antyll

Species: Human
Age: 37
DEXTERITY 1D+1
 Blaster 3D, dodge 4D
KNOWLEDGE 1D+1
MECHANICAL 2D+2
 Repulsorlift operation 4D, sensors 5D, space transports 4D+2, starfighter piloting 5D+2
PERCEPTION 2D
 Bargain 5D+1
STRENGTH 2D

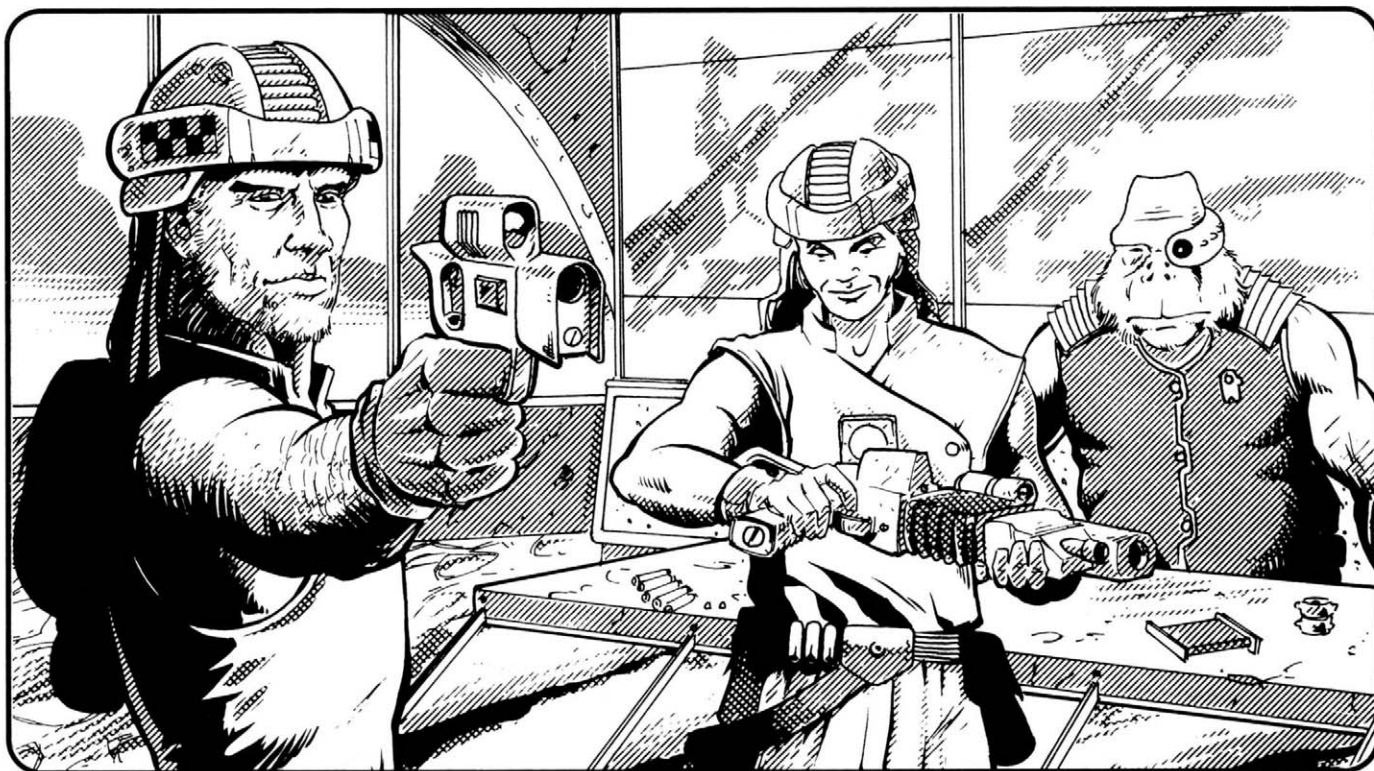

John Paul Lona

TECHNICAL 4D+2

Armor repair 5D, blaster repair 5D+1, capital starship repair 6D, capital starship weapon repair 6D+2, repulsorlift repair 6D+1, space transports repair 9D+2, starfighter repair 9D+1, starship weapon repair 9D

Force Sensitive?: No

Force Points: 0

Dark Side Points: 0

Character Points: 15

Move: 10

Equipment: Comlink, fluid-spattered work suit, blaster pistol (4D damage), several cigarras, hat, any number of starship repair tools, datapad.

Description: Dom always looks like he has just crawled out from underneath a leaking cargo

ramp: covered in fluid and grease, with sweat trickling down his nose. He is always chewing on a cigarra (he never smokes them), and all of the pockets in his work suits are full of tools. He looks tough and talks tough.

Personality: Determined. He knows his business and doesn't like people questioning his abilities. If someone argues about the quality of his work, he doubles his price. If people pay his fee and get out of the way he is happy.

Quote: "You don't think I can do it? Well, son, that just doubled the fee ... and I tell you what: I'm the *only* person in this town who can fix that plasma transvector. Pay or walk to Coruscant ... it's your choice."

22. Spaceport Hotel

There's not much to say about the "Spaceport Hotel" except that the quality of the service is about as imaginative as the name of the business. It's adequate and nothing else. There are about 40 small rooms available for rent, each about 15 credits a night (up from the 10 credits a few

seasons ago). The beds are almost comfortable, the sonic showers work ... mostly, and the air conditioning unit works at least some of the time. The Sullustan clerk doesn't ask questions, so he feels that customers shouldn't ask for favors.

23. Mos Eisley Spaceport Control Tower

In the heart of the city, the Mos Eisley spaceport control tower is responsible for directing incoming traffic to landing bays, and is one of the few structures in the immediate vicinity fed by the city's central distribution system.

The tower consists of a single Sienar Observation Module, which juts up five stories tall, and a two-story building that contains centralized administrative offices. The age of the tower can be verified by the ID plates showing "Republic Sienar Systems," predating the collapse of the Old Republic.

The observation module is designed for up to six Droids, with accommodations provided for Humans to take over in an emergency. Only three stations are occupied at any one time (one by the J9-5 worker Droid and two by Human technicians). The module also has a landing beacon so all incoming ships can instantly get a fix on the city.

When an incoming ship is detected by the spaceport's scanners, the central computer compares the transponder code with the spaceport's database of pertinent data. Meanwhile, one of the

operators (either a technician or the Droid) hails the ship, requesting the ship's name, previous port, purpose of visit and duration of stay.

There are a large number of corporate-owned ports in Mos Eisley; these ports have pre-arranged landing times and fees, and are responsible for their own customs inspections. If a ship identifies itself as being scheduled to land at a corporate bay, the tower quickly confirms the order with the company and then waves the ship through immediately, assigning a flight path. Companies will often send up escort vehicles, either cloud cars or fighters.

If the ship is scheduled to land in a private bay or doesn't have a pre-arranged bay, the landing procedure can take a bit longer. First, if a ship is landing at a corporate bay, the database search is cancelled; by landing at a private bay, a ship runs a greater risk of being caught for past illegal activities, although this is rare (see below). Second, if the ship has no pre-arranged bay, the tower assigns a bay, informing them of landing permit cost (normally about 20-40 credits a day),

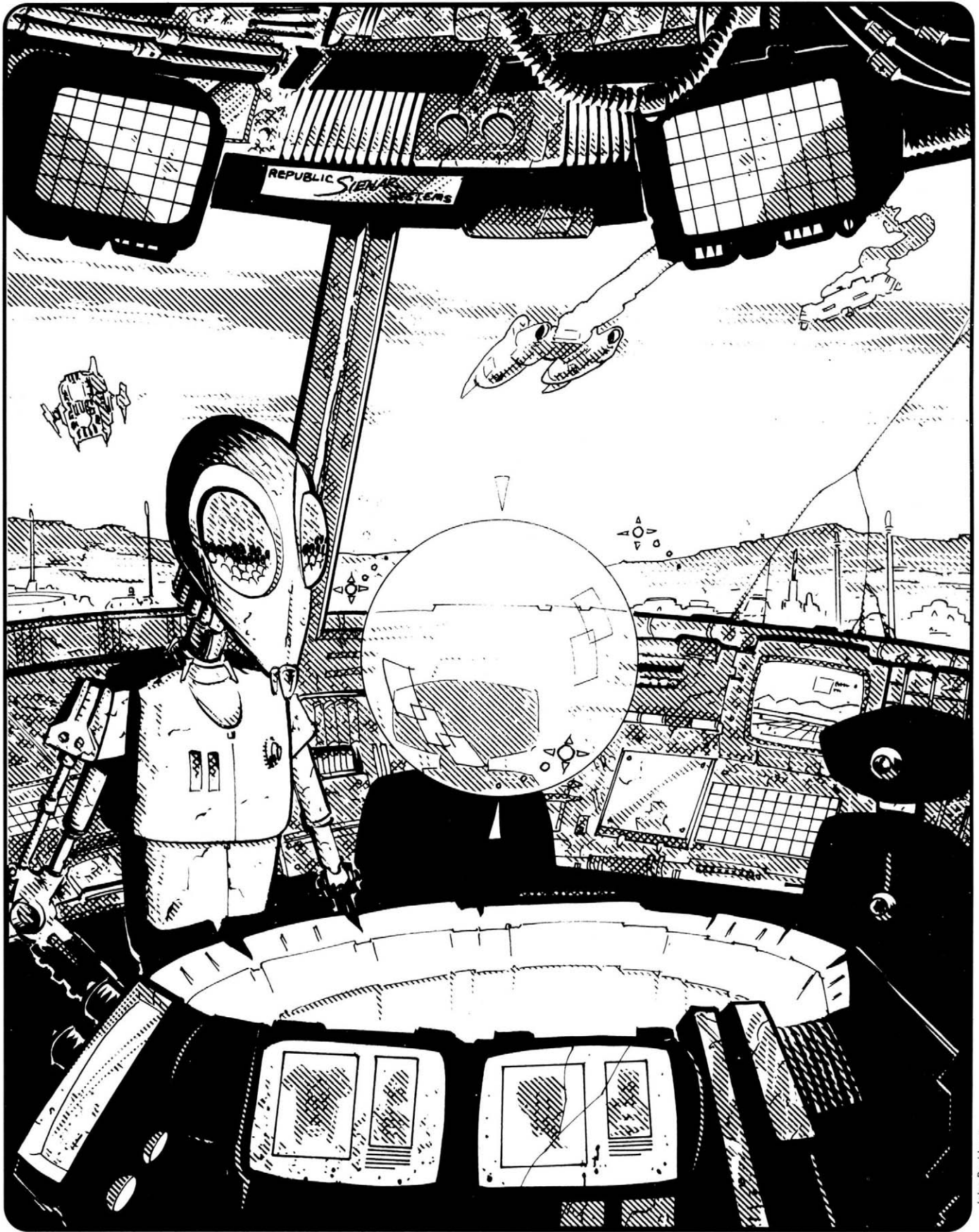

John Paul Lona

But They'll Sail Right On Through Customs!

Well, yes, they will. Almost any ship — illegal or not — will be able to pass the Mos Eisley Controllers unless, of course, they get JayNine-Five. This is consistent with preserving the feel of Mos Eisley as a lawless town.

This situation is set up to facilitate deliberate story manipulation. It is easy to allow the characters to just breeze through customs if that is desired; if the characters need to be given a tough time, have JayNine-Five assigned to their ship. The characters, if they will be making frequent runs into and out of Tatooine, should probably glean the information about the Droid from older spacers at the local watering hole.

Other spaceports around the galaxy have similar elements which you can manipulate to allow as much or as little harassment as you please (perhaps a spaceport does no computer checking at all, but every *other* ship is personally inspected by an orbiting customs frigate). Just remember that just the *threat* of capture or harassment can often be as exciting as actually being apprehended, and avoids the monotony of, "What story do we tell the spaceport goons *this* week?"

and the control tower informs the ship how long it has been cleared to stay in Mos Eisley (which seems to have no relation to how long the ship's captain actually *wants* to stay in Mos Eisley).

After this, the tower sends the flight path coordinates and asks if the ship requires an escort — if so, the pilot must wait a few minutes for one of the beat-up tan cloud cars to escort the ship to the appropriate bay.

At first glance, it seems that it would be unusually easy for ships to be caught by the control tower. However, the spaceport's database of ships, restricted cargo types, wanted craft and other such pertinent data is incredibly slow. In addition, the central computer of the control tower is suspect: a few years ago it tried to have Moff Julstan's yacht impounded. As a result, the two technicians on duty often simply wait an appropriate amount of time, and then wave a craft through; J9-5 often keeps a ship in an orbiting holding pattern until the ship is cleared, unless the technicians overrule her and wave the ship through. If the computer detects a ship it deems questionable, the two technicians are still likely to wave it on through unless there is overwhelming evidence that the ship is guilty of wrongdoing; J9-5 will often demand a full investigation (she is almost always overruled on this too).

Personnel

The control tower is worked by two Human technicians and a Roche J9 worker Droid (the Droid is on duty at all times; there are three different technicians, so there are always two on duty). The technicians are unconcerned about

their job: they only work hard enough to prevent mid-air collisions. The Droid, however, follows regulations to the letter, and thus is despised by most traders and smugglers who visit the city.

The Droid despises the lackadaisical attitudes of her co-workers, but she has refrained from reporting it. The last time she attempted to, the two technicians on duty managed to unscrew her hip joints and she spent the next three weeks rooted to the spot until a maintenance Droid took pity on her and found her legs. Since that time JayNine-Five has used a mid-body support if she needs to stand for any length of time (several bolts are still missing).

J9-5

Model: Roche J9 Worker Drone

Height: 1.9 meters

Move: 4

DEXTERITY 2D

KNOWLEDGE 4D

Alien species 5D+1, bureaucracy 4D+2, languages 4D+1

MECHANICAL 1D

Communications 3D, sensors 2D+1

PERCEPTION 3D

Bargain 4D+2, sneak 4D

STRENGTH 2D

TECHNICAL 3D

Force Sensitive?: No

Force Points: 0

Dark Side Points: 0

Character Points: 2

Equipped With:

- Video sensor
- Bipedal locomotion
- Olfactory sensor
- Microwave sensor
- Arjan vocabulator
- TranLang II Communication module

Description: JayNine-Five is a Roche J9 Worker Drone of indeterminable age. She stands 1.9 meters tall, and would fall over if not for a mid-body support which she leans on. She has insectoid eyes, and piston-like limbs.

Background: JayNine-Five has been shuttled from owner to owner over the years due to her fussiness; she follows orders to the letter. She has finally found a job in which her punctuality and adherence to discipline is valued by her owner. Unfortunately, the same cannot be said for her spaceport control co-workers.

Personality: JayNine remains a bit nervous, doing her best to ignore the antics of her bored colleagues.

Objectives: To follow the rules of her job as exactly as possible, and avoid her co-workers.

A Quote: "*Millennium Falcon*, you are cleared to land. Do not deviate from your present course. Welcome to Mos Eisley."

24. Lucky Despot Hotel

The *Lucky Despot*, in its original incarnation, was a battered cargo hauler; when the ship became so beat up that it failed all safety tests, its owners let it sit idle until investors, lured to Tatooine by the supposed potential for tourism, purchased it. Foolishly optimistic, they felt that if they only built a better hotel, beings from all across the galaxy would come to see the sights. They took the ship out of the docking bay in which it had been sitting for decades and carted it off to an empty lot.

The *Despot* was sunk into the ground, with one deck below surface level and three above ground. It then was equipped with the best in entertainment and luxury facilities. A ground set of stairs, running from street level to the top deck, was installed with a retractable canopy. The round viewports were replaced with aquariums, each holding rare fish from a different world; a holographic projector, called The Star Chamber, was installed in the casino. It was designed to show the galaxy in all its splendor, portraying a full-color map of the galaxy as seen from Coruscant, the Old Republic's capitol. Deluxe carpeting, imported wood paneling and luxurious furniture was installed in each room.

Alas, the anticipated influx of visitors never appeared, and the *Lucky Despot* owners were ruined. Years later, a young Whiphid named Valarian, with an eye out for new investment opportunities and looking for a new base from which to operate her growing criminal empire, greased a few paws and took over the hotel.

Jabba had a vested interest in frustrating the Whiphid. Valarian discovered the ship had never been decommissioned and found herself paying tax on the property, as well as needing to keep up the required permits to operate a passenger liner. Next was the inexplicable difficulty in obtaining a liquor license, then the impossibility of getting a gambling license (she still hasn't received one).

Never one to worry about official paperwork, Valarian opened anyway. Jabba retaliated with thugs, fire bombings, and legal wrangling. Valarian was stubborn, however, eventually learning the source of her problems; she now pays off Jabba, and promises to remain a small operation. In exchange, the crime lord alerts her to any planned police raids which attempt to nab her illegal gambling operations. To date, the agreement has held. Eventually, Valarian intends to upset the Hutt, but she is biding her time, marshalling her forces, and probing her enemy for weaknesses. When an opportunity presents itself, she intends

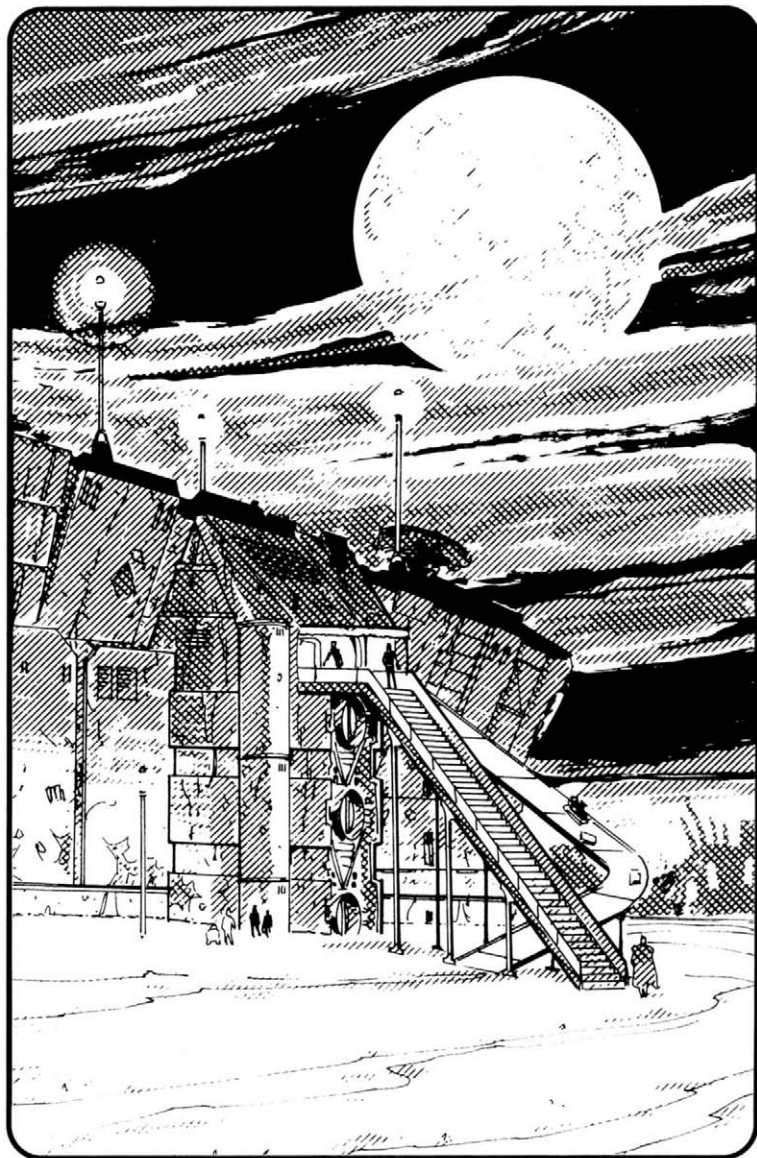

to be ready for it.

As for the *Lucky Despot*, Valarian has yet to pump any real money into it, and it shows. The Star Chamber celestial ceiling only partly works. The carpet is worn and faded. The first class staterooms are third-rate. Most of the rare fish in the porthole aquariums have died off. Most of the empty portholes have since been transformed into advertisements for local businesses and terrariums for native Tatooine life, such as ugly bone-gnawers and hideous gravelmaggots.

On the plus side, the food is excellent. The walls are made of durasteel, riveted and kept gleaming. The walls of the top deck curve up

The Lucky Despot

Top Deck

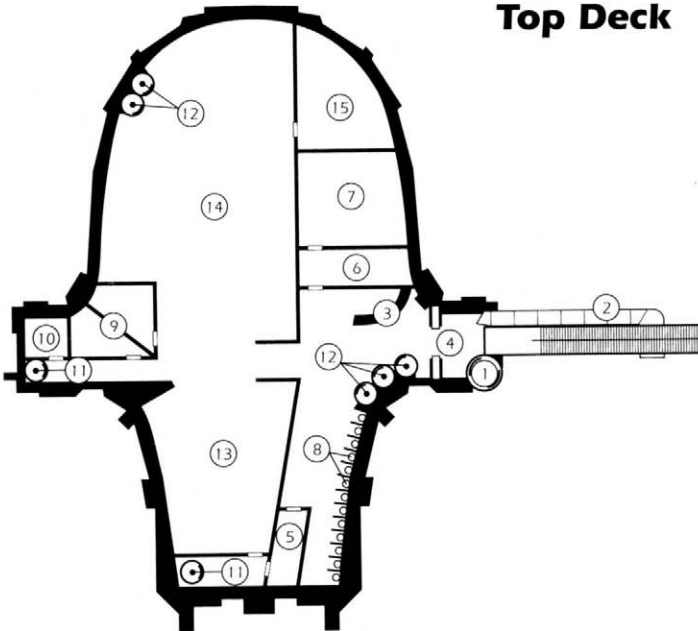

Lower Decks

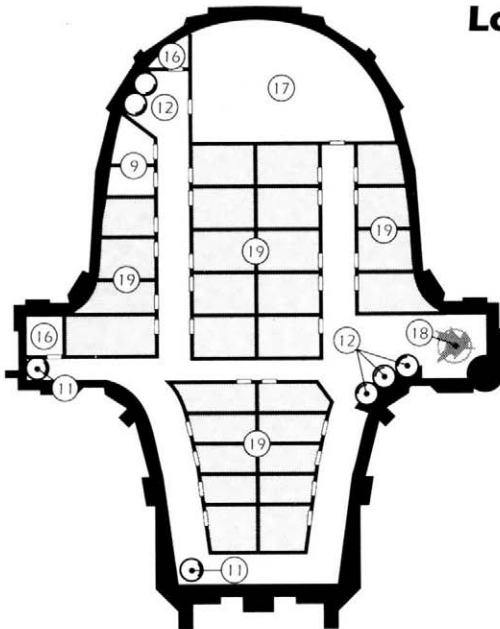

toward the ceiling, which has been replaced with a transparisteel viewport with a retractable canopy (the viewport is open at night for viewing the stars).

There is a staff of 40 here, counting six Droids for maintenance, maid, valet and cooking service.

1. Grand Staircase And Main Entrance Turbolift: This is the main entrance for all passengers and

customers (employees use the service entrance). Both the staircase and the turbolift go only from street level to the top deck; those wishing to go to other decks on the *Lucky Despot* must use other turbolifts. Characters often have to watch out for R2-Q5, a clumsy waiting Droid that seems to fall down the stairs at least once a day.

2. Ramp: Recently installed, most employees are still tripping over it.

3. Front Desk And Lobby: Usually staffed by one of a pair of identical twins, passengers are often tickled pink when they finally figure it out. The pair, Anton and Sturn Brunwin, are attractive humanoid aliens from Kiffu, with a penchant for swindling. Although Valarian hasn't yet noticed, the two have begun a money-laundering operation on premises. Guests are given passkeys for the various turbolifts in the *Despot*. There are always three guards dressed in bright orange uniforms with hold-out blasters (3D+2 damage) and comlinks (attributes of 2D, *blaster* 4D, *dodge* 4D).

4. Blast Door And Droid Detector: The broken Droid detector has not been fixed by Valarian. Despite common attitudes, she has no problem serving Droids (some of her best agents have been Droids), and in fact has six of them working at the *Lucky Despot* — *without* restraining bolts. The bar is even stocked with lubricant. When the ship is shut down for the night, the blast shield is lowered into position (*Strength* 7D). A door has been put in the shield, staffed by a security guard throughout the night.

5. Gift Shop: This shop has countless garish and overpriced trinkets to remind visitors of the *Despot*, in addition to souvenirs that are from the *Kuari Princess* and other famous passenger liners and vacation spots. Costs are anywhere from 10 to 50 credits for sculptures, shirts, holocubes and other mementos. The gift shop also stocks entertainment holos, medicines, toiletries, snack foods and other items that guests are likely to want.

6. Manager's Office: The current manager, Venutton, is a wiry, nervous man. Obedient to Valarian for as long as she continues to blackmail him, he is an efficient manager and runs a tight ship. His office is small and ordinary.

7. Valarian's Office: Much larger and richly appointed, Valarian examines any interesting conversations her observation devices have come across, in addition to plotting her schemes from this office. She is seldom in her office, as her criminal activities often take her away from the *Despot*.

8. Public Communicators: These holo vid booths are hooked into Mos Eisley's city-wide communications system (each conversation costs .5 credits per minute). For extra fees, calls can be made outside the city limits (upwards of

Valarian

Species: Whiphid
Sex: Female
Age: 24
DEXTERITY 2D+1
 Blaster 4D, dodge 3D+2
KNOWLEDGE 1D+2
 Business 2D, languages 3D+1,
 streetwise 3D+2, value 3D
MECHANICAL 1D
 Repulsorlift operation 4D, space trans-
 ports 2D+2
PERCEPTION 3D
 Bargain 4D+1, command 5D+1, con 4D,
 investigation 3D+2
STRENGTH 3D
 Brawling 5D+2
TECHNICAL 1D
 First aid 5D, (A) medicine 2D+1
Force Sensitive?: No
Force Points: 2
Dark Side Points: 1
Character Points: 12
Move: 9
Description: A young Whiphid, tower-
 ing and intimidating.
Background: Valarian seemed des-
 tined for a life of crime. The daughter

of two gangsters, she achieved a criminal record early. Once her parents were put behind bars, this freed Valarian to run away and really start moving into the big leagues.

Her latest gamble, opening the *Lucky Despot* under Jabba's nose, is paying off. He is leaving her alone to pursue her interests, and her interests include finding out what Jabba is up to. Being the second-best crime boss on Tatooine doesn't bother Valarian. She knows that she will soon assume a larger throne.

Personality: Valarian has a positive attitude. She has always succeeded in her varied interests and she has no reason to think she will fail in this goal. She enjoys the company of Droids and treats them as equals.

Objectives: To destroy Jabba the Hutt and take over his business.

Quote: "My goodness, stop blathering. I do not handle business like some other crime lords do. I think this can be settled quietly. I understand that the shipment was lost. Consider yourself on probation, and report for your next assignment. The value of the cargo will be deducted from your cut of this new shipment. This time."



John Paul Lona

1 credit per minute), including low orbit transmission to starships. These are a profit center for Valarian, as well as a font of useful information.

9. Restrooms: Typical shipboard accommodations.

10. Luggage Check And Staff Dressing Room/Lounge: This open area is used by Valarian to keep tabs on her employees. It is rigged with various monitoring devices, controlled by a panel in her office.

11. Service Turbolifts: These go to all levels, allowing staff personnel to move around easily. They are also emergency exits, although anyone who accesses them without appropriate passkeys will trigger an alarm at the front desk.

12. Turbolifts: All turbolifts in the ship can accommodate up to six beings. Passkeys are required to summon or direct a turbolift.

13. Lounge: This area is a meeting place for anyone involved in clandestine operations aboard ship. Strikingly boring, this area does have numerous booths for private conversations (unfortunately, the whole room is bugged).

14. Star Chamber Café: The restaurant serves meals throughout the day, but once Second Twilight is over, and the blast shield is lowered, it becomes Lucky Despot's casino. The gambling

tables are, for the most part, holographically projected onto existing tables. Cards and dice are hidden in the employee lounge so Valarian can claim they are employees' personal effects. The games requiring physical devices are stored off the kitchen in empty food crates.

15. Kitchen. All of the *Despot's* food is prepared here, and corner crates hide gambling machinery by day.

16. Linen And Support Services. Supplies, linen, and other common items are stored in these rooms.

17. Function Rooms. These rooms support various activities, from business conferences, to guest entertainments, to rooms for private parties. They can be rented for 150 credits per day.

18. Native Tatooine Sandcastings. Elaborate sculptures made from colored sands, adhesives, rocks, shells and other items found in the wilds of the Dune Sea, each sandcasting is considered a work of art, and they are quite popular among the trendy wealth mongers of the Core Worlds. These particular castings were made by a poverty-stricken artist, but are nonetheless beautiful.

19. Guest Rooms. Guest rooms have single or double beds, entertainment consoles, and other amenities. They are comfortable by Tatooine

The Tatooine Bureau of Travel and Commerce Presents

Enjoy the spectacle of an interstellar voyage
without the expense, *and* without ever having to leave home ...

The Cruise of a Lifetime!

The Lucky Despot is your ticket to a fantastic weekend getaway. Permanently "moored" among the picturesque buildings of the oldest part of Mos Eisley (complete with on-site security), the Despot is an authentic decommissioned starship transformed into a fabulous dune-side hotel resort. Enjoy a starfaring voyage in home port — safely and in the greatest comfort — aboard the fabled Lucky Despot.

- The exotic Star Chamber café features a unique starfield projector. Designed to recreate the galaxy in all its majesty and wonder, the holographic display projects a portion of the cosmos as seen from Imperial System! See planets and moons revolve in full color, at speeds of up to fifty times their normal orbits. Watch holographic comets fly right into your soup!

- Visit our gift shop and pick up holocube mementos of your "journey": the Lucky Despot stocks holocubes from most major cruise lines. Let your friends think you were aboard the Kuari Princess.

- The rumble of the hotel's food and water processing plant helps sustain the illusion of a ship's engine: you can actually envision yourself cruising effortlessly through the galaxy on a luxury yacht. All the excitement of a shipboard cruise for one-tenth the cost of those chartered "Galaxy Tours."*

- Experience an authentic ship's stateroom. Each cabin is part of the original craft or was purchased from decommissioned "luxury" cruisers. The close quarters that early settlers might have experienced have been painstakingly maintained to make your stay as true as possible.

- Instead of endless sandy vistas, many of the ship's viewports have been transformed into aquariums, containing exotic fish from a score of alien worlds, while other viewports are now exciting terrariums — each hosting an unusual example of native Tatooine wildlife. Few residents have actually seen a bonegnawer or gravel-maggot this close!



This season, the *Lucky Despot* is proud to present an exclusive engagement of the remarkable acoustics of SySnootles and the Max Rebo Band. Fresh off a multi-sector tour, they have returned to the lovely *Despot* for your entertainment. Their sound has been described as "the most original interpretation of a Sinfonia concertante I have yet to experience."

There's a luxury stateroom waiting for you!

*Registered galactic trademarks of Galaxy Tours, Inc.

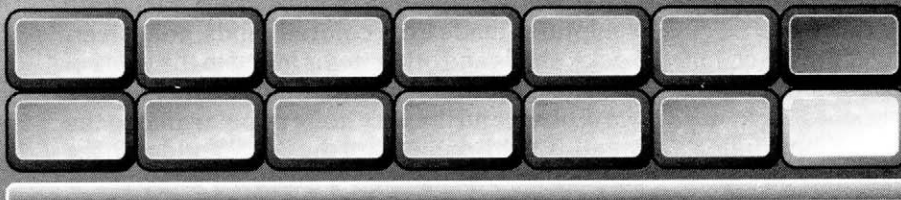

standards, but primitive by the standards of most civilized systems. At 50 credits per night, they are overpriced. Some also come with climate, atmosphere and gravity controls for the comfort of guests, although they are more expensive, and since they are left over from the original spacecraft's systems, old and sometimes unreliable.

Typical Lucky Despot Employee

Template Type: Obsequious Waiter

DEXTERITY 2D+1

Dodge 4D+2

KNOWLEDGE 2D

Cultures 3D, languages 4D+1

MECHANICAL 2D

PERCEPTION 2D+2

Con 3D+2, gamble 4D+1, sneak 4D+2

STRENGTH 2D

TECHNICAL 2D+1

Force Sensitive?: No

Force Points: 0

Dark Side Points: 0

Character Points: 0-5

Move: 10

Equipment: Tray, drinks, menus

Quote: "May I suggest the Ondo Lava '39. An excellent, full-bodied wine, with just a hint of Dewback spritz."

25. Zygian's Banking Concern

Little more than a branch office (the Zygian savings and loan corporate office is actually located on Trelon II), Tatooine's Zygian's building is in the heart of the old section of Mos Eisley. Due to Mos Eisley's poor economy, the bank has slowly evolved into a pawn shop of sorts. Items left as collateral on failed loans have begun to clutter the vault area, forcing the officers to either consign the items to local shops or sell them themselves. Considering the financial straits

the branch office was in, they went into business for themselves.

Despite its reputation as a pawn shop, Zygian's offers several features which makes it attractive to a potential customer.

- A triple-lined vault. The safe has a computer-controlled timed entry, allowing access only twice a day, at second dawn and second twilight. The vault has a *Strength* of 8D, and a Very Difficult *security* total is necessary to pick the lock. Typi-



Mike Vilardi

cally, there is a total of 200,000-300,000 credits in hard currency on deposit.

- Just outside the vault proper is a selection of safe deposit boxes (*Strength* of 6D, Moderate *security* total to pick the lock).
- A loan rate of *merely* 15%. This is a far cry from the typical loan shark rates of 300% or more. Not only is the interest rate much lower, but the "penalties" for missed payments are definitely less severe.

The collateral required for a loan is typically twice the value of a loan.

There are two clerks working at Zygian's: Sylvet Depp (brother of the late Prefect Depp), and an

attractive near-human female named Debrelle. In addition, there is Givvers, the manager, a full-time maintenance Droid and two bank guards, who alternate shifts (attributes of 2D, *blaster* 4D+1, *dodge* 5D, *search* 4D), with a blaster pistol (4D damage) and a datapad/comlink that immediately alerts the militia when a specific keycode is entered.

One large meeting room has been turned into the pawn shop. An additional part time staffer works here, helping customers.

Historically, there has been little trouble in Mos Eisley insofar as bank heists are considered. Residents who misrepresent themselves and skip out on loans, however, are a steady problem.

26. Police Station

With the added attention Tatooine received as a result of Lord Vader's efforts to capture stolen technical plans, Mos Eisley's Prefect Talmont has found himself expanding the size of the police force. Formerly, Mos Eisley relied exclusively upon a small part-time militia and half a dozen stormtroopers to keep order. Now, Talmont has added a full-time police force (small as it is at only 20 officers), and increased the size of the militia. However, the larger force required room for numerous speeders and related equipment, necessitating the purchase of a building in one of the newer sections of the city.

Despite new facilities and increased funding, the militia-turned-police are laid-back about crime and corruption. The roof of the main building is flat, and contains a marked landing pad designed for air speeders and cloud cars; there is a ladder leading to the ground.

Patrol officers are not assigned desks because they use personal datapads to process information about arrests and complaints. Since Tatooine residents all possess I.D.'s, a simple swipe of the card through the datapad brings up all records on that inhabitant, including address, closest family members, and other pertinent information. This enables patrol officers to operate in an independent fashion.

1. Desk Clerk: From here the desk clerk has monitors enabling him or her to watch all four holding cells, the entrances to the building, the roof, the basement, and the corridors. Monitors here display the same information as those at the duty station (location 12). All building entrances are equipped with sand traps. The door leading into the station proper can be locked from the desk clerk or the duty station, has a *Strength* of 6D and the lock requires a Moderate *security* total to pick without triggering an alarm.

2. Fines And Permits Office: Parking fines, moving violations, vehicle permits and other minor offenses are handled out of this office.

3. Property Room: All property confiscated from suspects is held here until given back to the owner, or released as evidence to a trial court. Here also is where suspects have their retinas scanned and catalogued, and their imaged holo'd for police mug shots.

4. Detective Offices (5): These offices are designed for the detectives assigned to Mos Eisley. Currently, there are two empty offices.

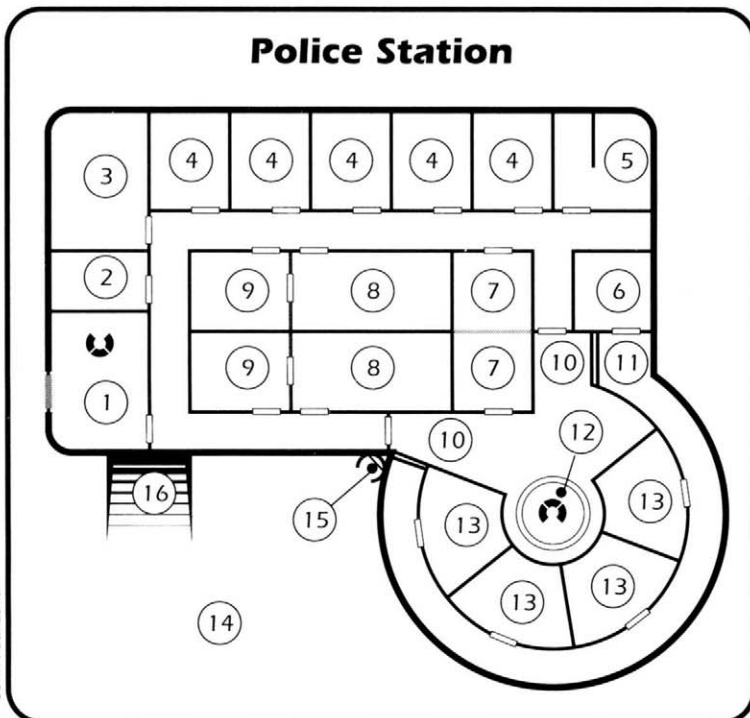

5. Chief's Office: The Chief of Police, Lieutenant Harburik, has a corner office. He prefers a hands-on approach, however, and can rarely be found behind his desk; he does carry a comlink with him at all times so he can be contacted if necessary.

6. Questioning Room: This room is used to question, or if necessary, interrogate suspects and criminals. It has a security door, with a keypad required for entry. (Easy *security* total to pick the lock.)

7. Visitation Room: This room is now bisected by a sheet of transparisteel. Microphones allow communication between a suspect and the visitor. The wall has a *Strength* of 3D, so it isn't truly an obstacle to those determined to break out.

8. Locker Rooms, 9. Rest Rooms (2): There are two sets of changing rooms and sonic showers for the officers, along with access to the public rest rooms.

10. Security Doors (2): These reinforced doors have a keypad for entry (Moderate *security* total to pick the lock; *Strength* of 6D).

11. Perimeter Alley: This curved hallway is two steps lower than the main floor. This is the

sole method of access to the cells.

12. Duty station: From here the duty officer can watch all four holding cells. This station is elevated above the main floor.

13. Cell (4): Lower than the main floor are four holding cells. The cells include reading lamps, a bunk, rest room facilities, and a mirror. At the top of the wall, facing the duty station, each cell has a one-way transparisteel mirrored window, to allow the duty officer to physically view the entire cell. (These tiny windows have a *Strength* of 6D.) The opposite wall is composed of iron bars with a *Strength* of 4D; the lock only requires an Easy *security* total to pick.

14. Speeder Parking: This lot accommodates the patrol scooters, as well as the police officer's civilian transportation.

15. Ladder: This ladder goes from the roof speeder landing pad to the speeder parking lot.

16. Speeder Ramp: This is a sloping ramp leading down to the basement of the building, which has the speeder maintenance garage. The ramp has a sand trap "cover" protecting the cellar from sand. There is a full-time mechanic on the payroll.

27.

The House of Momaw Nadon

Momaw Nadon's home represents a typical upscale Tatooine residence. The opulence is obvious in the incredible amount of water the Ithorian utilizes. Indeed, the house is almost a miniature ecosystem. Momaw Nadon's home lies at the cul-de-sac of a quiet "street," formed by two long residential buildings, on the southern edge of the city. From the outside it looks fairly ordinary, with the typical two-story white pourstone construction; the ecological wonderland inside is a different story.

The humidity is the first thing to hit a visitor. The insulated walls have actual condensation on them. The water originates from an artificial pond in the center of what would normally be an entertainment area. Wildlife of all kinds inhabit the forested room, with a majority of the water, flora and fauna spilling over into the living room, in the first subterranean level below.

The windows in the house are all very near the ceiling, and diffused. There is no direct light which hits the plants. This keeps the temperature down, and mimics the diffused light which penetrates the overhead canopy of Ithor's jungles.

Few have entered his abode, and none without an invitation. He performs all the maintenance

duties by himself: fertilizing the soil, feeding the animals, and changing the water purifier filters.

Momaw has several carnivorous plants to scare unwanted visitors. One particular plant, a Vesuvague Hanging Tree, is semi-intelligent. Momaw has stationed it over a secret room in which Rebel agents seek refuge; it listens to Momaw's commands and will attack on command.

Vesuvague Hanging Tree

DEXTERITY 5D+1

PERCEPTION 2D

STRENGTH 4D+2

Attacks:

Vines (4D+2 damage)

Digestive juices (6D+1 damage)

Momaw Nadon

DEXTERITY 3D

Dodge 4D, melee combat 3D+1, melee combat: powerstaff 4D+2

KNOWLEDGE 3D+2

Cultures 4D+2, survival 3D+1, survival: jungle 5D

MECHANICAL 2D+1

Repulsorlift operation 4D+1

PERCEPTION 3D+1

Bargain 4D+1

STRENGTH 3D

Lifting 4D

TECHNICAL 2D+2

First Aid 4D+2

Force Sensitive?: No**Force Points:** 2**Dark Side Points:** 0**Character Points:** 8**Move:** 9**Equipment:** Agri-kit (+1D to *survival*), powerstaff (STR+2D damage)**Description:** An Ithorian of some age and grace, Momaw has a sandy-brown color, typical of Ithorians who spend a great deal of time away from their homeworld. His dual-throated stereo voice is unmistakable.**Background:** Momaw was herd leader of *Tafanda Bay*, a grand visitor center on his

homeworld. When the Imperials demanded the agricultural secrets of the Ithorians, Momaw knew that to refuse would mean the destruction of *Tafanda Bay*, and the loss of many lives. He complied and the Ithorians banished him.

Momaw moved to Tatooine to nurse his pride. Once there, he set up contacts with the Alliance. He also fell in love with Slag Flats, a Tatooine settler and one of the original colonists. Since her death, he has slowly realized he was using Slag as a diversion from his feelings. He knows the time is nearing when he must return to the Mother Jungle and prove his value.

Personality: Momaw is a lonely Ithorian, in self-inflicted exile. He speaks softly and is a very gentle being.**Objectives:** To regain his place among his people so that they agree to his anti-Imperial position.**A Quote:** "Sometimes one must turn the soil to save the garden."

28. Transport Depot

The transport depot is a decrepit and unsafe building not far from the center of the city. The west end of the large building has a cafe, serving waiting passengers overpriced and undercooked food; the east end offers the ticket booth and rest rooms. The center area has chairs arranged in

rows, with several video monitors to catch the latest Tatooine broadcasts; only two of the monitors actually work. Since Tatooine's lone broadcasting station closed down years ago, all information on the airwaves is on disk, and the prerecorded commercials and programs are brought

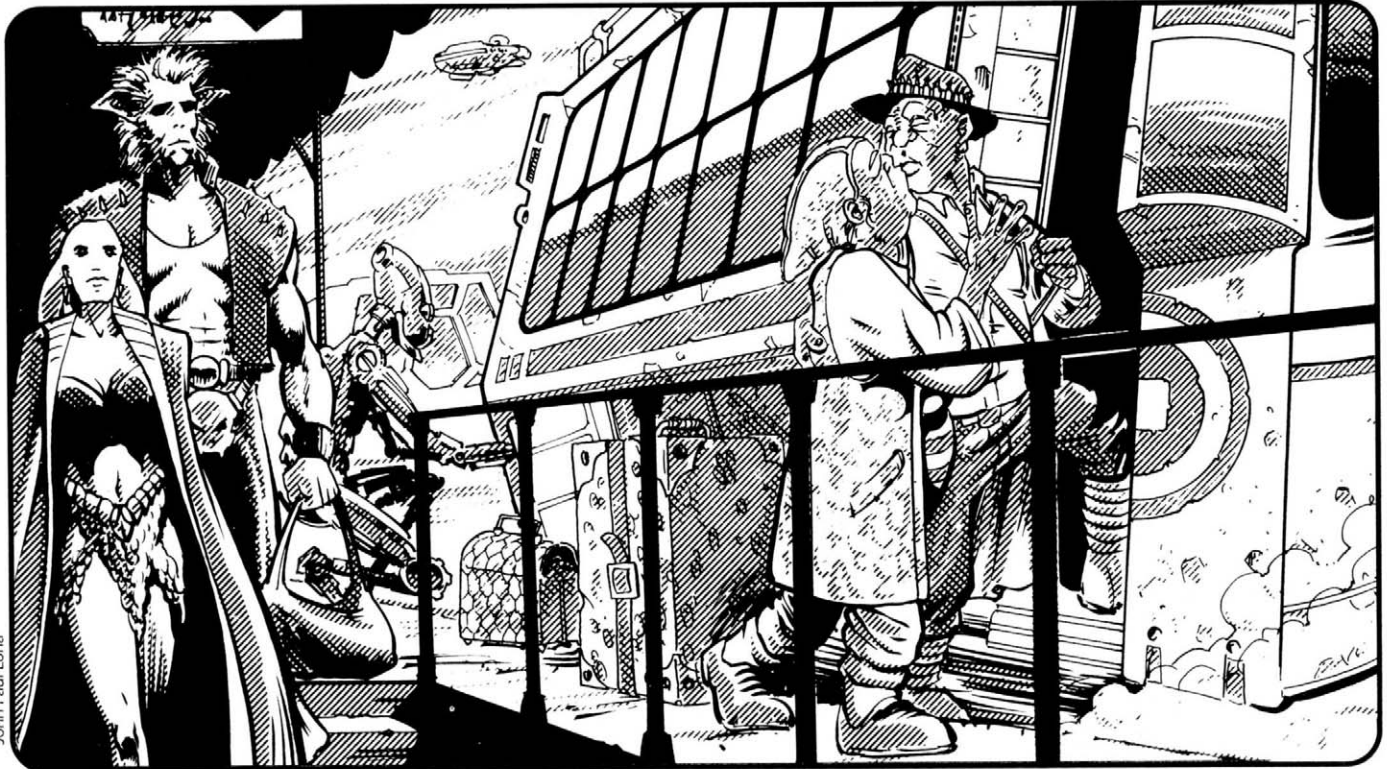

in once a month. The cost is one credit per ten minutes.

There is a bank of lockers along the back wall, of varying sizes. They can be rented for 4 credits a week, or 1 credit per day. They use a key lock, with an Easy *security* total to pick the lock. Near the front door is a set of videophones with a maximum range of near-orbit (as long as there are no sunspots or sandstorms).

The proprietor of the depot is a near-Human named Yvonne Targis. She is a nasty yellow-skinned spinster of some unknown age. Her hair hangs down in wisps from the green bun atop her head, and her nails are often jagged.

Yvonne works for Jabba the Hutt. Some valuable objects are dropped off by smugglers at the depot, until one of Jabba's cronies picks it up.

The depot offers transport to almost any settlement on Tatooine, although that isn't saying much. The company purchases whatever becomes available, so transports include tourbus speeders, sail barges, and cargo haulers.

The following routes and times assumes a thirty minute layover at each stop, with transports available every three days. The transport makes a complete loop, returning to Mos Eisley (including the Anchorhead "Circle Route" around the Jundland Wastes); the direction of travel is

alternated with each journey. For every stop, the ticket costs 2 credits. Therefore, going from Mos Eisley to Bestine when going west to south costs 2 credits, but going south to west costs 8 credits.

The transports are rarely on schedule, and sometimes the whole run is cancelled. Yvonne's house rule is that there must be at least four beings wanting to ride in order for her to allow the R2 unit driver to leave the terminal. Of course, she blames engine trouble or sandstorms on the "delay."

Routes and Times

South to West

Location	Arrive	Leave
Mos Eisley	—	09.00
Anchorhead	10.50	11.20
Motesta	13.40	14.10
Arnthout	16.15	16.45
Bestine	18.20	18.50
Mos Eisley	20.20	

West to South

Location	Arrive	Leave
Mos Eisley	—	09.00
Bestine	10.30	11.00
Arnthout	12.35	13.05
Motesta	15.10	15.40
Anchorhead	18.00	18.30
Mos Eisley	20.20	

29. The Cutting Edge Clinic

Welcome to a clinic run by a doctor with outstanding warrants on over 53 planets. A doctor who has been given the death sentence in 14 systems. This scourge of the galaxy is none other than the infamous Doctor Evazan.

Under the name of Dr. Cornelius, this evil man runs an office out of a nondescript building in the heart of Mos Eisley.

The shop is a four-room affair. The reception room is a tiny area containing little more than four chairs and a receptionist. His clerk is a Devaronian named Jubel.

The clinic specializes in cyborging, but the operations are seldom successful. The deranged doctor has even used Droid parts instead of cybernetic equipment upon occasion. Normally, his patients, often desperate and destitute smugglers, ship hands and other transitory individuals, disappear after his failed operations, and the authorities haven't the time or inclination to look into the matter.

Doctor "Cornelius"

DEXTERITY 3D+2

Blaster 4D+2, brawling parry 4D+2

KNOWLEDGE 2D+2

Business 3D, languages 4D, streetwise 4D+2

MECHANICAL 2D+2

Repulsorlift operation 4D+2, starfighter piloting 3D+2

PERCEPTION 2D+1

Bargain 3D+1, con 4D+1, gambling 3D+2

STRENGTH 3D+2

Brawling 4D+2

TECHNICAL 2D

First aid 5D, (A) medicine 1D, (A) medicine: cyborging 2D+1

Force Sensitive?: No

Force Points: 1

Dark Side Points: 2

Character Points: 6

Move: 10

Description: A medium-built man, whose most startling aspect is his twisted, squinty-eyed face. His stilted speech and obnoxious manner contribute to his loathsome appearance.

Background: Dr. Cornelius is none other than the infamous Dr. Evazan, scourge of the galaxy. His obsession with surgical cutting and sewing has caused untold death and horror. His narrow escapes are the stuff of legend. His return to

Tatooine in the dead of night is bad news for anyone unlucky enough to come under his knife. He is hiding from his Aqualish companion, Ponda Baba, who was nearly killed by one Evazan's failed cyborging operations.

Personality: Evazan is as twisted as his countenance. Although he can assume the attitude of a concerned doctor, the moment the patient is

asleep the maniacal laughter of the doctor is proof enough of his insanity.

Objectives: To keep practicing his creative surgical procedures.

A Quote: "Yes, I understand how important good looks are. Now, here is the hand that will be installed."

30. Dim-U Monastery

Visitors to Mos Eisley are quite likely to encounter street preachers praising the wisdom and perfect nature of the Bantha. These preachers are from a "model" community out in the wilderness run by monks of the Dim-U religion. However, there is a splinter group with a monastery in Mos Eisley itself; this group has no street preachers, but those who would seek enlightenment and aid may approach the monastery.

Both groups are opposed to the continued expansion of settlements that encroach upon the

Bantha's traditional foraging grounds, including the introduction of new industry. Other than that, the two groups seldom associate with each other.

However, the monastery has a much more sinister truth. The building, despite the assertions of its "abbot," was chosen for its low rent, low visibility, and proximity to the Mos Eisley Bureau of Ships and Services (BoSS) office. The Dim-U monastery is a cover for a criminal group that actively spies on the BoSS offices, and operatives make a small fortune forging transponder codes for wanted starships.

The building was an abandoned greenhouse that the Dim-U sect offered to refurbish at no cost. Drayk, the abbot of the Monastery, is a shrewd deceiver. He changes both the location and facade of his organization every few seasons and since his last front was a Bantha stable, he had enough visits from the Dim-U clergy to fake an organization based on their religion. The constant harping and harassment about ecological concerns for the Banthas, along with the ongoing religious disagreements with Oasis, insures that the focus of attention is on the antics of the monastery, and not the monastery itself.

From the crypts of the monastery, corrupt agents tap into the datafiles of the local BoSS office and monitor the transmissions from the office. Every six months a BoSS ship drops out of hyperspace and orbits Tatooine just long enough to receive the updated transmissions from the office, and for the office to download updates from the rest of the galaxy. The BoSS ship then kicks back into hyperspace to continue its route. These transmissions are decoded for review prior to transmission — it is during these times that Drayk's slicers break into the BoSS computer system, altering, adding or deleting data as necessary.

The monastery employs a group of mechanics who can pull apart a sublight engine in order to alter its transponder codes. His mechanics work in complete secrecy, and normally only at night for added protection. If a ship is too large for a landing bay, a special expedition can be mounted outside the city, but of course, at extra cost.

This all costs money — payment in advance.

Transponder Codes

Every ship in the civilized portions of the galaxy is equipped with a transponder code: a unique signal beamed out continuously to identify each ship. The code includes the ship's name, type, owner, and any pertinent data about the ship. This code is built into each sublight engine, and is created by giving slight variation to the frequency of the engine's emissions. This variation, as well as data about the ship, is encoded in the transponder director that is sealed into the engine itself. This information is regulated, handled and dispersed by the Bureau of Ships and Services (BoSS).

There are three ways to alter transponder codes. The easiest is to replace a ship's engines with engines from another ship, hopefully one with a cleaner record. A second way is to have false transponder codes installed in an engine. When the ship is scanned, it will be identified as a completely different vehicle — this is a tricky, expensive forgery, for if the attempt is failed, the transponder will often melt the engine's internal components down, ruining it. The final, and even riskiest, approach is to actually tamper with BoSS's files directly. This is very difficult because the codes are in an almost indecipherable code. However, Drayk has learned how to tamper with decoded files, making this process much simpler.

Agents from BoSS are reputed to be incorruptible; Jabba the Hutt has found this to be largely accurate. BoSS's Tatooine agents were long ago approached by Jabba the Hutt; the gangster received no special deals, but was offered the opportunity to purchase any information he desired, on par with other governments.

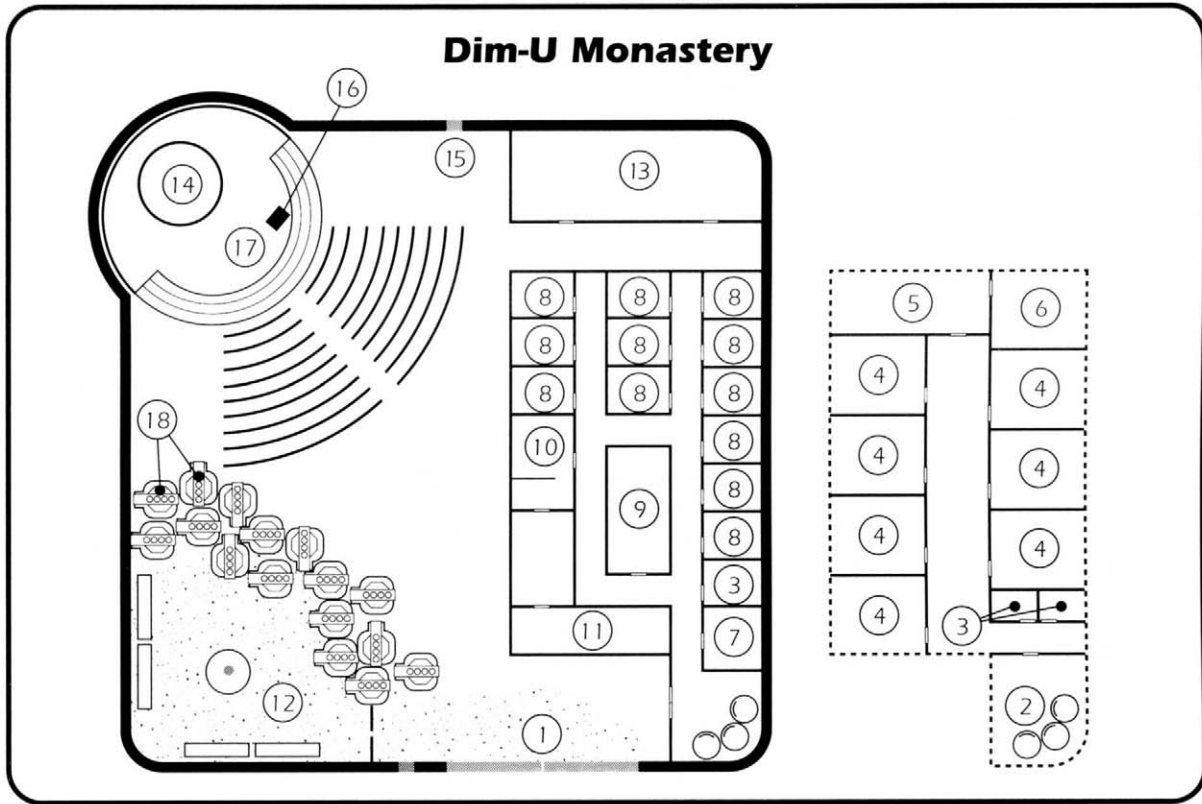

John Paul Lona

This payment plan might startle newcomers to the business, but Drayk has no need to swindle a prospective purchaser. For a file change, with no engine work involved, Drayk usually charges 5,000 credits (although if a ship is particularly infamous, such as the *Millennium Falcon*, the cost is much higher).

For custom jobs requiring dismantling a ship's engine to change the transponder director, the fee begins at 5,000 credits (for the file change) and goes up from there. A typical Corellian light freighter might be another 5,000-10,000 credits, while any Mon Calamari ship — each as unique as its designer — might run as high as another 100,000 credits.

Drayk is aware that some of his business can only be attributed to Rebel activities. He has no position on the civil war, but does appreciate the added profits it brings him. Drayk is also very well connected — he can put a customer in contact with gun smugglers, forgers, bounty hunters, hired guns or any other questionable service.

1. Main Entrance: The huge doors are rarely opened. Instead, visitors are guided to the smaller adjacent gate.

2. Underground Lobby: This room is accessible only from the turbolifts. This is the entryway to the illegal aspects of Drayk's operation. Two monk or nun guards are here at all times, armed with hidden blasters. They prefer to discourage unwanted visitors, rather than directly challenge them.

3. Rest Rooms.

4. Workshop (7): Here the technicians work on modifying transponder codes by rebuilding or modifying ship transponder directors.

5. Conference Room (Level 1), Tech Room (Level 2): The conference room can hold 18 beings, and sports a burnished table which holds the latest in holographic projection technology.

The tech room is the nerve center of the complex. It is from here that the actual BoSS tap is achieved. This room of computer equipment is hooked into several relay satellites on the roof of the building, concealed among older debris.

6. Workshop (Level 1), Abbot's Office (Level 2): This room is a standard workshop on the first level. The second holds Drayk's office. He possesses a system of cameras hooked into various strategic locations about the monastery.

7. Guest Parlor: Here the occasional visitor is entertained. This room is a spartan version of a hotel room, complete with two double beds and bathing facilities. Drayk has a key to this room.

8. Cell (12): These are the individual rooms for the nuns and monks of the monastery. A typical room has a bed, dresser, video comlink, and entertainment console.

9. Quiet Room: According to the Dim-U, this is a room for reflection and introspection. It is actually a game room, with a holochess game, as well as an auto-pool table and gooth ball court.

10. Abbot's Quarters: These rooms are off-

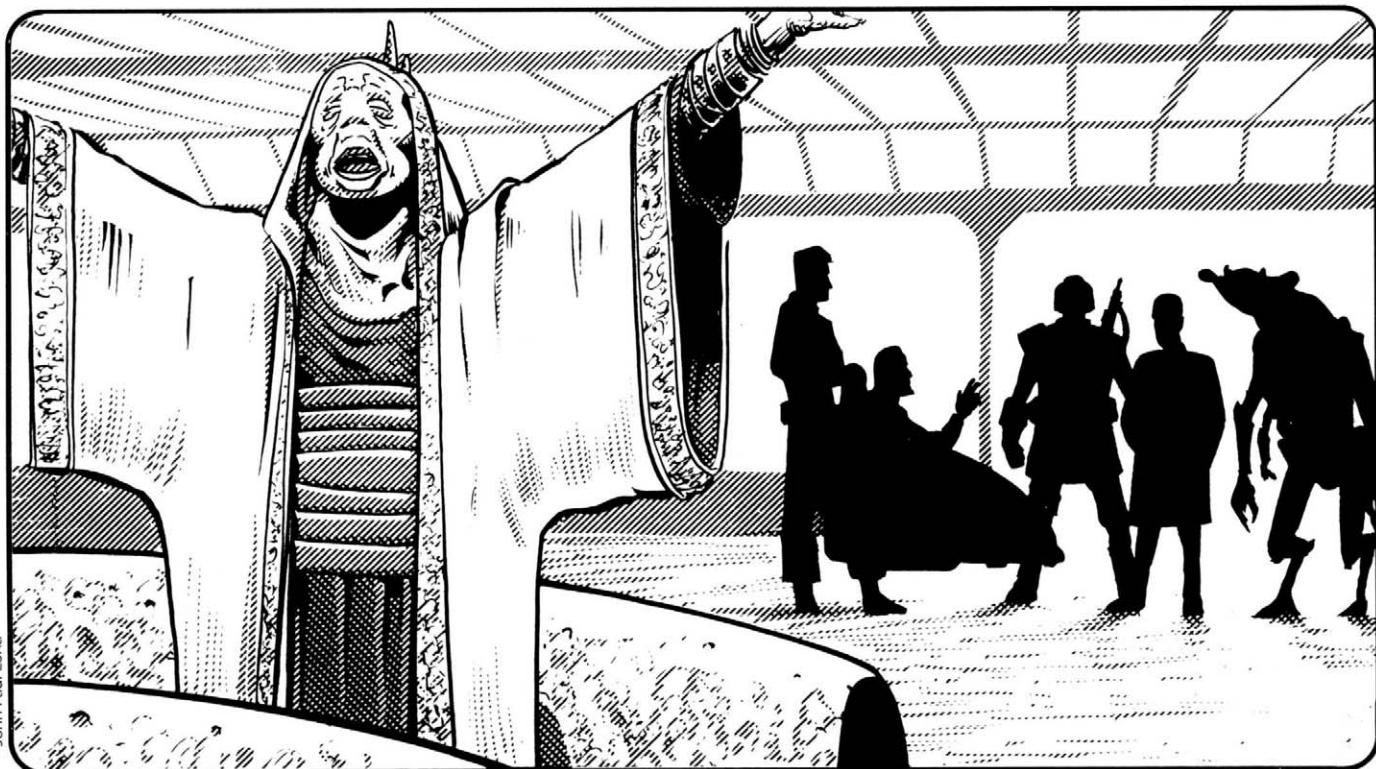

John Paul Lona

limits to anyone but Drayk. He can control all the equipment in his office from here. He employs an Industrial Automaton SE-4 Servant Droid named R02-E.

11. Scriptorium: Here is stashed the computer memory banks for all work that the monastery has performed over the years. It is constantly backed up and older storage modules are copied and updated onto new media. There are high explosive charges rigged all about the room, which may be triggered from the abbot's quarters or abbot's office. If necessary, Drayk has no compunction about destroying all records since he has complete back-ups hidden somewhere, although he won't reveal where (or even if they are on Tatooine).

12. Bantha Stable: A collection of six sorry-looking Banthas mill about here at night. By day they remain penned in a corral built against the outside east wall.

The Forger's Art

How difficult *is* it to completely change a smuggler's identity and ship information? The short answer is: it depends. It may take a while — "Sure, I can give you new I.D.s, but your Droid, see, I don't do Droids. A friend of mine on the fifth moon, however..."

On the other hand, it can be a brief, painless, but nonetheless expensive process. The amount of time and hassle can easily be customized to fit the adventure at hand.

Bantha

DEXTERITY 2D
PERCEPTION 2D
STRENGTH 8D

Orneriness: 2D

Move: 15

Size: 2.5 meters at the shoulder

Attacks:

Horns: 7D damage

Trample: 8D damage

Banthas are commonly used as beasts of burden. The rare Bantha that has been trained for combat will attempt to trample, but most are shy, fighting only when necessary. Banthas can carry about 500 kilograms of cargo, or up to five beings. The six Banthas at the Dim-U Monastery are domesticated, and will flee when frightened.

13. Kitchen And Refectory: A substantial kitchen and dining area were modified from the original equipment left here. Much of the programming and hookups are unorthodox, but ELGaR — an LGR series Industrial Automaton Cooking Droid — manages to keep everything on this side of disaster.

14. Bell Tower: This equipment used to power the boom, which is now stationary and juts out over the nursery pits. The machinery here was converted to a simple signal tower which chimes each hour on the hour.

15. East Gate: This gate is never used. In fact, everyone has forgotten it exists. It is sealed and

Drayk

DEXTERITY 2D+1

Dodge 3D+2

KNOWLEDGE 1D+1

Bureaucracy 4D, business 5D, languages 4D+2, law enforcement 4D+1, streetwise 6D+2

MECHANICAL 2D

Repulsorlift operation 4D+2

PERCEPTION 2D

Bargain 7D+1, con 6D, forgery 9D

STRENGTH 2D+2

TECHNICAL 1D+2

Computer programming/repair 3D, repulsorlift repair 2D

Force Sensitive?: No

Force Points: 2

Dark Side Points: 2

Character Points: 14

Move: 3

Equipment: GoCorp hoverscooter, datapad, comlink, blaster pistol (4D damage)

Description: Drayk uses a GoCorp

hoverscooter to get around. He has a penchant for clothes which suggest a military style.

Background: Drayk, the abbot of the Dim-U monastery, is quite a jump from the political clerk of yesteryear. After a speeder accident left him paralyzed from the waist down, Drayk stopped chasing short-term goals and set out to build a personal fortune. Drayk has an uncharacteristic soft spot for those he thinks are in trouble through events not of their own making. Being what he calls "a victim of circumstance" himself, he will go out of his way to correct a wrong.

Personality: Drayk is a very calm man who plans as far ahead as possible, and has at least three contingencies for every problem. He is unruffled by most turns of events, and the only time he gets excited is at the thought of an unhappy customer.

Objectives: To get rich.

A Quote: "The job will cost 5,000 credits."



John Paul Loma

has a *Strength* of 5D.

16. Pulpit: This gantry used to be an overhead, mobile feeding sprayer for the three-bin nursery below. It is now fixed in place and serves as a pulpit from which to sermonize when Drayk feels the need to mislead guests.

17. Cathedral: A huge reactor-turned-temple, the massive chamber still reflects its origins as the massive electrical turbines remain aligned in pairs down the length of the room. The monks and nuns have set up pews from which to revel in the word of Drayk during faked ceremonies.

18. Fusion generators (16): These rusted hulks are all useless and remain from the original greenhouse experiment. They are not salvageable and lay about the factory in disarray.

GoCorp JL7 Elixir Hoverscooter

Craft: GoCorp JL7 Elixir Hoverscooter

Type: Hoverscooter

Scale: Character

Skill: Repulsorlift operation: Hoverscooter

Crew: 1

Passengers: None

Cover: 1/4

Cargo Capacity: 5 kilograms

Altitude Range: Ground level-1 meter

Cost: 2,000 credits

Move: 10; 30 KPH

Maneuverability: 3D

Body Strength: 2D

Weapons: None

Typical Monastery Nun

Template Type: Dim-U Priestess

DEXTERITY 3D

Blaster 4D, dodge 4D+2

KNOWLEDGE 3D

Bureaucracy 4D+1, language 3D+2

MECHANICAL 2D

Astrogation 3D+1, starfighter piloting 4D,

starship shields 2D+1

PERCEPTION 3D

Con 5D

STRENGTH 2D+2

TECHNICAL 4D

Computer programming/repair 5D+2, space

transports repair 6D, starfighter repair 6D

Force Sensitive?: No

Force Points: 0

Dark Side Points: 0

Character Points: 1-5

Move: 10

Equipment: Comlink, hold-out blaster (damage: 3D+1, range: 3-4/8/12), Dim-U robes

Quote: "The way of the Bantha is one of majestic beauty and calm peace. Oneness with the natural world. We strive to understand the power of the creature."

31. Notsub Shipping Company

Notsub is easily the largest company on Tatooine and employs almost 1,000 beings and 300 Droids. Located on the northern edge of the city, the company is far from the cramped downtown area, while being close enough to allow many employees to walk to work.

Notsub's main industry is shipping, but the company also owns a stock brokerage, as well as a half-dozen other minor interests, and owns controlling stock in over 50 more companies. Notsub also owns Notsub Security, one of the largest private security firms in Mos Eisley.

Notsub owns a cluster of several warehouses, some of which have roofover landing pads, docking bays, as well as its corporate headquarters, which is a large, two-story affair.

Diversification has been the thrust of Notsub for the past ten seasons, thanks to CEO Armanda Durkin. As Notsub has spread its influence, its

financial picture has improved as well.

Armanda's Rise

Notsub's upward-looking balance sheets weren't always so optimistic. When she first began at Notsub, Armanda Durkin was determined to make a good showing and wanted to make some quick credits. She invested in some high-risk enterprises early in her tenure at Notsub, but things didn't quite turn out the way she had hoped: a water-drilling investment came up dry; the owners of a telescope manufacturing company couldn't focus on their product; and a brokerage house went broke.

Undaunted, Armanda decided to take matters into her own hands. She reviewed the shipment manifest for the next few months, and came up with three very interesting prospects from three different manufacturers. All were raw materials,



John Paul Lona

Armanda Durkin

DEXTERITY 3D+1

Blaster 4D+1, dodge 4D+2, melee combat 5D

KNOWLEDGE 3D

Bureaucracy 4D, planetary systems 3D+1, planetary systems: Tatooine 5D

MECHANICAL 3D+1

Astrogation 4D, repulsorlift operation 3D+2, space transports 5D+1

PERCEPTION 4D

Command 6D, con 7D+1

STRENGTH 2D+1

Brawling 4D+2, stamina 6D+2

TECHNICAL 2D

Computer programming/repair 3D, security 5D+2, space transports repair 2D+1

Force Sensitive?: No

Force Points: 3

Dark Side Points: 2

Character Points: 21

Move: 10

Equipment: Comlink, high quality space suit, blaster pistol (4D damage, 3-10/30/120)

Description: Armanda has a penchant for brocade and silks, and only the finest of those. Her hair is luxurious

and often done up in a complicated style. When disguised as the Duchess, she tucks her auburn hair under an aviator cap, and hides her svelte figure in a flight jumpsuit.

Background: Armanda Durkin — wealthy power broker and shipping magnate. She is driven to succeed because of tragedy. Her husband was injured and their business was destroyed in a mysterious fire. The insurance company, Maltsett, refused to pay, citing an obscure legal reference. Without the insurance payment they could not afford the treatments needed to save his life. Now she leads a double life, stealing her own shipping to make Maltsett pay for its crimes.

Personality: Armanda, after so much tragedy, cares for nothing more than money or success, although her conscience has bothered her after several unnecessary deaths due to her piracy.

Objectives: To keep Notsub's coffers full, using the blood of the Maltsett insurance company.

A Quote: "Please remain seated or we will be forced to knock you unconscious."

all were to be shipped on Notsub's Corvettes, and all were insured by Maltsett Insurance Company. Since she had a personal grudge against Maltsett, Armanda set into motion a wild swindle.

Getting financing to purchase an armed and armored freighter was performed with little effort. Getting a transponder signal altered was no problem and picking up a signal jammer was easy, considering her wealth. And aligning herself with the type of people willing to do the tasks she required was incredibly easy, considering the fact that she was in Mos Eisley.

She and her group of toughs left that night on this new freighter, the *Vengeful Sandstorm*. A Corvette carrying plastisteel left a Notsub dock destined for an office building at the Imperial maintenance facilities on Myomar. The ship never made it out of the system. Armanda's freighter overtook the plodding Corvette, and undermanned and poorly armed, the Corvette's crew surrendered. Armanda's thugs lightened the Corvette's load and left for the far side of Tatooine's moon, where they waited for the rest of the night. Armanda was later able to sell the plastisteel at a tremendous profit, plus she was able to claim insurance money for a stolen cargo.

Thus began Armanda Durkin's double life as the pirate named Duchess.

Armanda Durkin has continued her piracy and her actions helped to turn Notsub around. With fluid capital, she was able to diversify, pursue highly profitable, but legal cargos, and make a lot of money. Her piracy continued (she began preying on non-Notsub ships in other systems), and thanks to companies who wouldn't question the source of products, made a fortune. Notsub has also purchased smaller companies that use materials directly, write off their raw materials purchases to bogus corporations, and manufacture high profit items.

Of course, Armanda is getting worried. If she continues, her piracy is likely to be revealed. She feels it is time to get out of the business. She was also spooked by a recent incident, when some unfortunate cargo haulers thought a cargo of Droid parts was worth fighting over — twelve of them lost their lives. Armanda discovered that the Droid parts were actually smuggled medicines. Through various contacts she was able to deduce that they were most likely destined for the Rebellion.

Thrung Alewune

DEXTERITY 4D

Blaster 4D+2, dodge 5D, melee combat 5D+1

KNOWLEDGE 3D

Streetwise 3D+1

MECHANICAL 2D+2

Repulsorlift operation 3D, starship gunnery 4D+1, starship shields 3D+1

PERCEPTION 2D

Gambling 3D+2, search 4D, sneak 2D+1

STRENGTH 3D

Brawling 4D+1, lifting 4D

TECHNICAL 3D+1

Computer programming/repair 4D+1, demolition 3D+2, space transports repair 4D+2

Force Sensitive?: No

Force Points: 3

Dark Side Points: 3

Character Points: 10

Move: 10

Equipment: Comlink, high quality space suit, 2,500 credits, blaster carbine (5D damage, 3-25/60/250)

Description: Thrung is a Ho'Din who has bound his ample violet locks to

his head and wears a cap. His height can be intimidating to those unfamiliar with his species' natural gentleness.

Background: Thrung Alewune is a typical pirate under Armanda's command. This Ho'Din has been around the galaxy a few times, so he has amply experience.

Thrung is getting weary of Armanda's moral code against killing. The group has missed out on choice opportunities for increased wealth simply because Armanda will not allow her crew to strip the passengers of their personal valuables. He has suggested to Armanda that it is time for her to hang up her pirate career; Thrung is gaining converts among her crew.

Personality: Thrung considers it an asset to exhibit none of his species' characteristic gentleness. He has renounced his species' love of nature and has turned all his energies toward increasing his understanding of technology.

Objectives: To insure profitable runs.

A Quote: "Look, I'm here just for the cargo. Don't try anything and we'll be out of here in no time."



John Paul Lona

32. Notsub Security

Notsub Security is the largest private security firm in Mos Eisley, employing over 500 people full time, and providing security to numerous small businesses and corporations. Like most Mos Eisley company patrol craft, Notsub's ships are licensed only for atmospheric travel.

The company is based in a two-story warehouse facility, only a few blocks from Notsub's corporate headquarters, containing no less than a dozen cloud cars, several unarmed land-speeders, and, of course, all supplies and equipment for its guards. Guards are typically given landspeeders for long-range patrols around large facilities, or conduct foot patrols for whatever smaller buildings are being patrolled. All Notsub contracted buildings have also been equipped with alarm systems, so that if they are tampered with, Notsub can send guards in response.

Typical Notsub Security Personnel

DEXTERITY 3D+1

Blaster 4D, dodge 4D+2, melee combat 3D+1

KNOWLEDGE 3D

Cultures 3D+1, languages 4D, streetwise 5D+2

MECHANICAL 2D

Beast riding 2D+1, repulsorlift operation 3D

PERCEPTION 2D

Search 4D, sneak 2D+2

STRENGTH 3D

Brawling 4D+2

TECHNICAL 2D+2

Security 3D+1

Force Sensitive?: No

Force Points: 0

Dark Side Points: 0

Character Points: 0-3

Move: 10

Equipment: Protective desert clothing, comlink, filtermask, Sharpshooter V blaster (4D+1 damage, 3-30/80/350)

A Quote: "Trespassing is against the law. Leave now or we will take you into custody by whatever means necessary."

Bespin Motors Hurricane 506 Cloud Car

Craft: Bespin Motors Hurricane 506
Cloud Car

Type: Twin-Pod Cloud Car

Scale: Speeder

Skill: Repulsorlift operation: cloud car

Crew: 1

Passengers: 1

Cover: Full

Cargo Capacity: 15 kilograms

Altitude Range: 50-100 kilometers



Cost: 60,000 credits
Move: 520;1500 KPH
Maneuverability: 2D+2
Body Strength: 2D+2

Weapons:**Double Blaster Cannon**

(fire linked)

Fire Arc: Front

Crew: 1

Skill: Vehicle blasters

Fire Control: 1D

Range: 50-400/900/3km

Damage: 3D

The twin-engine Hurricane Cloud Car is a single-cockpit vehicle, with a cramped toboggan-like space for the pilot and co-pilot. One of the variant predecessors of the highly popular Storm IV, the Hurricane has a tendency to roll to the left when accelerating. Other than that, however, it is a durable machine with an excellent repair record.



Chapter Three

Adventure Ideas

Mos Eisley is a rich and varied adventure locale, providing countless conflicts and personalities to interact with. Because of Mos Eisley's nature as a lawless, smuggling center, characters can be drawn here for any number of reasons. Smugglers and cargo handlers can be called here on a simple cargo run. Rebel Alliance operatives may have to come here in order to get information, weapons or contraband supplies (such as military-issue blast vests or heavy duty power generators). Characters may come here on a tour of the *Kuari Princess*, intent on a Krayt Dragon hunt. In the end, if characters are landing on Tatooine, they will pass through Mos Eisley.

Spice Runner's Gamble

A new spice merchant has come to Mos Eisley in an attempt to win Jabba's trade. The characters are targeted as one group who can help start this new smuggling ring.

This adventure allows characters to immediately get a feel for the nature of Mos Eisley and the people who live there; gullible characters are in for an interesting time. This adventure hook works best if the characters are destitute and willing to do almost anything to earn a few hard credits. But, then again, when *aren't* characters in this situation?

There are two ways to get into this plot. The first is if the characters find out about the smuggling ring and then volunteer for work. The second is to have the characters stumble upon the whole situation and get forced into participating, working as pawns for Jabba the Hutt.

Episode One: When the characters arrive at Mos Eisley, they will hear word about town that a new spice dealer has entered the crime scene in Mos Eisley. Most who talk about the situation are talking about how dangerous it is to intrude upon the Hutt's trade, and once Jabba finds out who is behind this they are dead. Nonetheless, the spice dealer is offering excellent prices — if someone can get a load or two before the Hutt cracks down, they stand to make a fortune.

The group spends some time tracking down rumors, going from bar to bar. It seems that no one wants to talk to them — and if they are too obvious, they will attract the attention of some of Jabba's goons (see their stats in location 13, "Jabba's Townhouse"), who will clumsily follow the characters around town. The characters should be able to figure out that they are being followed and be given ample time to lose them or set an ambush.

Eventually, they are told that a group of the new spice smugglers are meeting that evening in Docking Bay 56, a decrepit and abandoned docking bay on the northern edge of the city. If they

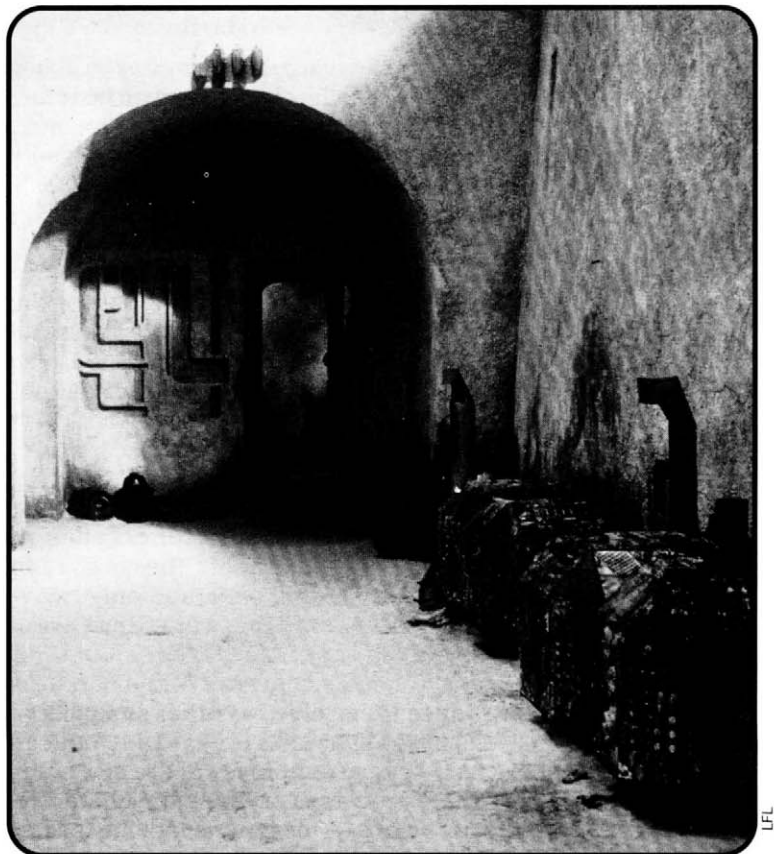



want a contract, they are to be there.

Episode Two: Arriving at Docking Bay 56, things appear suspicious. The characters will be totally justified in thinking that they are walking into a trap, although the information they received is legitimate. Characters making *Difficult search* or *Perception* totals will notice several disguised thugs near Docking Bay 56, and as the characters pass, the thugs call to someone on their comlinks.

As they approach the entrance of the docking bay, they are confronted by a tough-looking thug who approaches them from a darkened alley across the street. He questions them about their intentions, who told them to come here and so forth. If they answer truthfully, they are allowed to enter.

Entering the docking bay, they see a place that has obviously been abandoned for decades. All of the machinery is falling apart, the cargo ramp creaks when people walk on it, and only two or three of the dim landing lights work (there are no other lights in the bay). Soon, three or four other groups of individuals come out of the darkness, and introduce themselves as other smugglers.

A weaselly Rodian walks forward, introducing himself as Dwess, an employee of the new smuggling lord. He repeats everything the characters have heard before — his boss is looking for new spice smugglers — and tells them point blank

that this operation will be run differently than other smuggling operations. He is selling spice at the rate of 45,000 credits a “smuggle” load (half a ton) — less than a third of what a crimelord normally has to pay for one. The smugglers who buy the cargos are free to resell the goods to whoever they want to at whatever price they want. If they want in, they have to come up with a 5,000 credit deposit for the next meeting in two days.

Characters figure that if the deal is legitimate, they could earn a huge profit by selling directly to a spice dealer. Now, if only the characters could figure out a way to raise some credits to buy that initial shipment.

Episode Three: The characters have to spend their time trying to borrow money from less than legitimate sources (a bank isn’t likely to loan money for this type of operation). This means that they may have to approach Jabba, coming up with a cover story about “ship modifications,” or approach the gangster Valarian, or even try to approach one of their past customers. If the characters are having trouble, have them meet an eccentric, rich codger who is looking for adventure and excitement and who is willing to loan them the money in exchange for a cut of the profits.

Note: If the characters are to “stumble” into

this plot, they will simply hear about the meeting after it occurred. Unfortunately, some of Jabba's goons will think that they were at the meeting and will threaten them if they don't help them get Dwess by going to the next meeting.

Once they have secured the money, cut to the meeting. Dwess is present along with several new thugs, and a six-person airspeeder. He explains that the ships will be loaded in the sand flats to the south of town, where their business will be less conspicuous. He gives each of the smugglers a datamap (on datapad disc) in exchange for a deposit of 5,000 credits, telling them to meet him there in five hours. After getting their money, Dwess and his thugs take off into the night, explaining that they have to prepare their cargos. He gives each of the characters a small bag of spice as well, worth about 1,000 credits, as a show of good will and to prove the quality of the product.

If any characters appear unhappy with this idea, he will simply tell them to leave, and then send a group of his enforcers after them. If a firefight breaks out in the abandoned landing bay, Jabba's goons will charge into the fray as well, making for a complex situation for the characters: there is vast potential for confusion, as Dwess and his goons will try to escape with whatever money they can; Jabba's goons are trying to get Dwess, but also want to take out the smugglers; and, the various smuggler parties are trying to get out with their lives.

Episode Four: The final meeting spot, late at night in the sand flats outside of Mos Eisley. Whatever smugglers paid their money will be at the site, but not Dwess. However, there are some people who want to meet them—first, Tatooine's militia shows up, ready to arrest everyone carrying spice (that's why Dwess gave them the bags). Second, Jabba's goons arrive in force equal to the militia, ready to eliminate all of the smugglers who were willing to sell out to another spice merchant.

Surprisingly, the militia commanding officer decides to leave after confiscating the bags of spice and whatever credits the smugglers have with them. Jabba's goons will hold the smugglers prisoner for several hours, until just before dawn, when a small sail barge approaches. On it is Jabba himself, who is curious as to why the operation is taking so long. Then he laughs, ridiculing the smugglers—they have fallen for a con. Dwess had no other spice, and has simply taken their money. He releases the smugglers, encouraging them to hunt down Dwess and get their revenge, for he has made a fool of them all. If the characters ask around town, especially in the Mos Eisley Cantina, they will learn that a Rodian con man with a battered freighter lifted off a few

hours ago, destination unknown.

A Rebel Agent

The characters are investigated by Lieutenant Harburik, under suspicion of being Rebel Alliance agents. They must find some way to prove that they are innocent of the charges.

Episode One: The characters encounter one of their acquaintances in Mos Eisley, who warns them that something is up with the local Prefect, and it seems to involve them. He advises them to keep their heads low, and to try to find out what is going on; he says that they aren't advised to leave since the militia and even the stormtroopers based on the planet are probably trailing them.

He suggests that they go to the Mos Eisley Cantina and try to meet Beeyon Nace, a regular there who works for the government and seems easily bought for information.

Episode Two: Venturing to the cantina, they have a variety of "typical" street encounters, such as a firefight breaking out between rival thugs, a Jawa who tries to sell them an obviously malfunctioning Droid, and a thief who tries to



steal some credits while they are distracted by a street performer.

Once they get to the cantina, they can meet Nace easily, and he seems interested in talking to them as long as they are supplying drinks. They can quietly pump Nace for information: interspersed with ramblings he will let slip that the Prefect thinks that Voren Na'al, a researcher for the Rebel Alliance, is back on the planet. He thinks there's a reward worth several thousand credits on his head. The Prefect believes that one of the characters is Na'al, and Nace obliviously describes Na'al's companions, giving a complete description of all of the other characters. He says that the Prefect is trying to decode a datatape that Na'al left behind on a previous trip — at this point there is no hard evidence against the people the Prefect is seeking, but he figures he should capture and interrogate them now, hoping that they'll confess and he won't have to have the tapes decoded. The tapes are currently at the Regional Government Offices (location 11).

Nace will ask the characters for a ride off this miserable dust-ball, showing enthusiasm for being taken to almost any other world. The episode concludes when the Tatooine militia wanders into the Cantina and saunters over to the bar. The bartender shrugs, but a short alien with long, pointed ears points directly toward the characters. It's time for a fast exit ...

Episode Three: The characters should have concluded that they will have to break into or go to the Regional Government Offices. If they go during the day, there are three lazy clerks who pay the characters no attention unless they try to go into Prefect Talmont's office. They will try to stop them, but have no weapons and no alarms to sound, so the characters will certainly be able to force their way in.

If the characters try to sneak in under cover of night, no one works there. The door has an alarm and requires an Easy *security* total to open (failing the roll triggers the alarm). The can also pry

To: Prefect Talmont

From: Lieutenant Harburik

Subject: Apprehending and detaining suspect subversive #354

Sir, the investigation continues. The subject and his friends will no doubt be apprehended shortly.

The other disk contains the captured encoded datadisk which we believe to be from the subject. Translation efforts on our part have so far proven fruitless, although once we crack the code, no doubt we will have the evidence to convict him.

To: Lieutenant Harburik

From: Police Officer Dokus

Subject: Apprehending and detaining suspected subversive #354

Pursuant to your orders, the apartment was searched. Apparently the subject knew he was targeted for interrogation, because there was evidence of a hasty departure. The apartment itself revealed no clues as to his current whereabouts, although our informants place him as an active member of the Rebel Alliance.

The landlady has been thoroughly questioned. She has no information regarding the target's mission or destination.

All may not be lost, however. One of my officers located a datapad on which several files had been erased. We managed to extract most of the files using standard recovery protocols. However, the contents of the files were coded; we are currently attempting to unravel the codes. I'm certain that these files contain the evidence we require. I have enclosed copies of the files for your perusal.

Imperial Intelligence knows something of the author of these files, Voren Na'al. According to their records, Na'al served for several years as a reporter for the Galactic News Service. He is now assistant to the Rebellion's Master Historian, Arhul Hextrophon. Na'al has been reporting on the traitors intimately involved in the Incident at Yavin.

To: Police Officer Dokus

From: Lieutenant Harburik

Subject: Apprehending and detaining suspected subversive #354

Officer, this datatape may be of some use to us. Our encryptors are currently trying to determine the underlying codes to extract the sensitive information we require.

Good work!



To: Lieutenant Harburik
From: Prefect Talmont
Subject: Search for suspect subversive #354
 Harburik, this tape is garbage. The traitor obviously left behind this tape in a foolish attempt to mislead the Empire. Your investigators clumsily blamed several innocent persons. I want them disciplined.

Consider yourself fortunate that you are serving under the command of such an astute bureaucrat as myself; one who is not quite as gullible as you.

Destroy all copies of this nonsense, or I will make sure that this information is placed in your permanent record. It would be a shame to see you stuck on this planet forever.



open the windows with a Very Easy *Dexterity* total; there are no alarms on them.

When they break into Prefect Talmont's office, they will easily find a pair of datadisks, both labeled "V. Na'al Investigation," on his desk.

The first disk contains the memos regarding the Voren Na'al incident (see page 88).

The characters should try to alter the information — it's suggested that they choose something humorous, such as a recipe database. At the very least, it must be something so simple that it proves that the characters aren't Rebel sympathizers. Altering the information requires a Moderate *computer programming/repair* total, although the characters will have to keep low when militia patrols stop by to check on the building. The scene in which they are altering the information should be tense and dramatic, but not too dangerous.

Episode Four: The characters find out from Beeyon Nace or other contacts on the street that Prefect Talmont has realized that this was a colossal case of mistaken identity and they are no longer wanted for questioning.

They also learn from Nace or some other person involved with the government that what *really* happened is that the information was finally decoded and turned out to be whatever the characters inserted. Additionally, their contact got a copy of the memo Prefect Talmont sent to Harburik (see above).

Scavengers' Race

The characters learn that a modified Corellian Corvette crash landed in the desert during a brutal sandstorm. Notsub Shipping is offering a finders' fee of 5,000 credits to the first individuals who find it — Notsub can only track it down to a 2,000 square kilometer area, and sensor scans aren't able to pick out the ship. The characters will be racing several other groups and possibly

Jawa sandcrawlers for the find.

Episode One: The characters hear of the ship either through contacts they have with Notsub, or from some guards who are off-duty discussing the matter. They learn that the Corvette crashed far out in the desert and that Notsub is quietly sub-contracting groups to find the vessel. Notsub wants to keep the incident from becoming public knowledge for fear that other companies will try to claim it. Notsub will hire the characters, paying a 500 credit search fee, which is theirs to keep, and they will give another 4,500 if they find the ship.

The characters have one night to equip themselves with any gear they think they might need. Notsub will be loading them and three other search groups aboard a search vessel in the morning. If the characters decide to go out on the town, encourage them to have a run-in with another group of revelers — the group turns out to be a rival group of explorers.

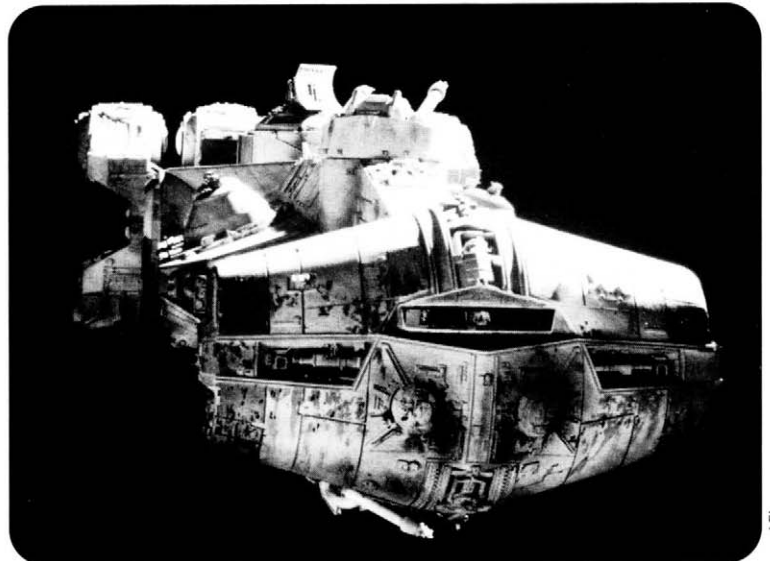



Episode Two: The characters meet at the designated landing bay at Notsub headquarters. All of the characters' gear is stowed aboard a Corvette, along with that of three other groups of rough mercenaries who are also looking for the ship. Each group is given a pair of airspeeders for the survey, in addition to survival gear.

The trip to the search site is a great opportunity to introduce the other search parties. At least one group should be antagonistic and clearly willing to be underhanded to get the prize money, and the Notsub guards refuse to stop the conflict — they don't care *who* or *how* the ship is found as long as it is found.

Once they land and make camp, the search can begin in earnest. However, Tatooine is a big desert. During the day, the characters can have a run-in with a Krayt dragon, or Tusken Raiders or any number of other natural hazards — a sudden

sandstorm could certainly liven things up. Additionally, feel free to introduce new predators to Tatooine — perhaps a Sarlacc type of monster, a sand-snake or other creature could prove exciting!

Eventually, just before a chilling and deadly cold night begins, the characters find the ship. However, they have to return to camp that night. Meanwhile, the rival group has figured out what the characters have done. The characters may choose to watch their rivals, or decide to salvage at night — no matter what, though, they will get no help from their employers unless someone seems ready to damage the ship.

Episode Three: The gamemaster will find the maps of the Corellian Corvette on pages 64 and 65 of *The Rebel Alliance Sourcebook* helpful in running this scene. The Notsub security guards inform the characters that their goal is the forward hold on deck four of the ship, and they must retrieve the gear. The ship's third and fourth decks are buried in the sand, so the characters will have to cut through the hull on the second deck and then make their way down. The guards call for assistance, and explain that cargo haulers will arrive in a few hours — until then, the characters must help retrieve the cargo to get their money.

All of the turbolifts are inactive; they'll often have to use access shafts to get between decks. All of the crewmen were killed in the crash and all on-board Droids have either been damaged beyond repair or ran out of power. When the characters investigate the ship, they face the following obstacles:

- Live cables prove an obstruction. The characters must make Moderate *Dexterity* totals not to touch them or find some way to remove or de-electrify them.
- Clumps of mynocks have attached themselves to the ship, entering through various holes. They need to be flushed out to get to the door on the other end of the hallway (see the *Star Wars Sourcebook* for mynock statistics).
- The way is blocked. They must turn back and find another route.
- A pack of womp rats have formed a den just outside the computer core, and have no desire to leave.

Womp Rat

DEXTERITY 2D
PERCEPTION 1D+1
STRENGTH 2D+1

Move: 5

Size: 2.1 meters long

Attacks:

Claws: 2D+2 damage

Teeth: 3D+1 damage

Ponda Baba

Height: 1.85 meters

Species: Aqualish

Sex: Male

Homeworld: Ando

Age: 29

DEXTERITY 3D+1

Brawling parry 4D+1, melee combat 4D+1

KNOWLEDGE 2D+1

Alien species 3D+2, intimidation 5D

MECHANICAL 3D+2

Astrogation 4D+1, space transports 4D+2, starship gunnery 4D+2

PERCEPTION 3D

STRENGTH 3D

Brawling 5D, stamina 5D

TECHNICAL 2D+2

Space transports repair 3D+2

Story Factors:

Obsessed: Ponda Baba is determined to get revenge against Dr. Evazan for his failed cybernetic experiments on Baba's arm.

Force Sensitive?: No

Force Points: 0

Dark Side Points: 0

Character Points: 12

Move: 10

Equipment: Blaster pistol (4D damage), grenades (5D damage), club (STR+1D damage)

Description: Imposing and intimidating, Ponda Baba dresses in common spacers' garb. Ponda Baba lost his right hand in a battle with Obi-Wan Kenobi; he hasn't yet received a prosthetic replacement, so his arm is a hideous sight. He attempts to conceal his weapons beneath his jacket, hoping to goad others into fights.

Background: Ponda Baba was a long-time companion to the infamous Dr. Evazan. The two had developed quite a reputation as smugglers, and were famous for starting fights with many defenseless foes in cantinas around the galaxy. Evazan's horrible mutilations of his "patients" were famous enough to earn him a death sen-

tence in over a dozen systems, and Evazan's victims are offering a million credit bounty on the doctor's head. Ponda grew to enjoy the notoriety and attention the Doctor's companionship earned — he learned that most people were scared of the doctor due to his reputation and would do anything to get the pair out of their company. Ponda found that he could get what he wanted with little hassle with Evazan at his side.

After Ponda lost his arm, Dr. Evazan attempted to attach a cybernetic replacement, but the operation was a miserable failure. While Dr. Evazan fled the world, Baba spent several weeks recovering from the trauma of the operation. Baba dedicated himself to hunting down and killing Evazan. After several months of unsuccessfully tracking leads, he has finally trailed his former companion back to Tatooine, where he is operating under the false name of Dr. Cornelius.

Personality: Gruff and intimidating. Ponda Baba is always itching for a fight, normally with those who appear smaller and weaker than he. He is greedy, cruel and altogether despicable. Since Ponda cannot speak Basic, he often starts a fight regardless of what response he receives. After his incident with Kenobi, he is now very leery of lightsabers.

Objectives: To hunt down Dr. Evazan and kill him. Nothing else matters at this point. Of course, the million credit bounty on Dr. Evazan's head will be nice too.

A Quote: "Negrh ghogola woldewa!" <<I don't like your face. Want to fight?>>



Combat: These vicious Tatooine natives attack in packs of up to five. The hairy carnivores usually circle once, then lunge. They scatter when a total of three wounds has been inflicted upon the pack as a whole or an *incapacitated* result has been inflicted on any single individual.

- When passing through a large area, noxious gas fills it (attacks with 4D versus *Strength* — on a *wounded* or better result, character is overcome

with nausea for five minutes; trying to do anything other than crawl suffers a penalty of -3D). If any of the characters are overcome with nausea, they are attacked by another pack of womp rats. They can attempt to wait until the fumes disperse, or they can actively try to pump it out. Perhaps they can reach the environmental controls to see if one or two blowers are functional.

When the characters finally arrive at the for-

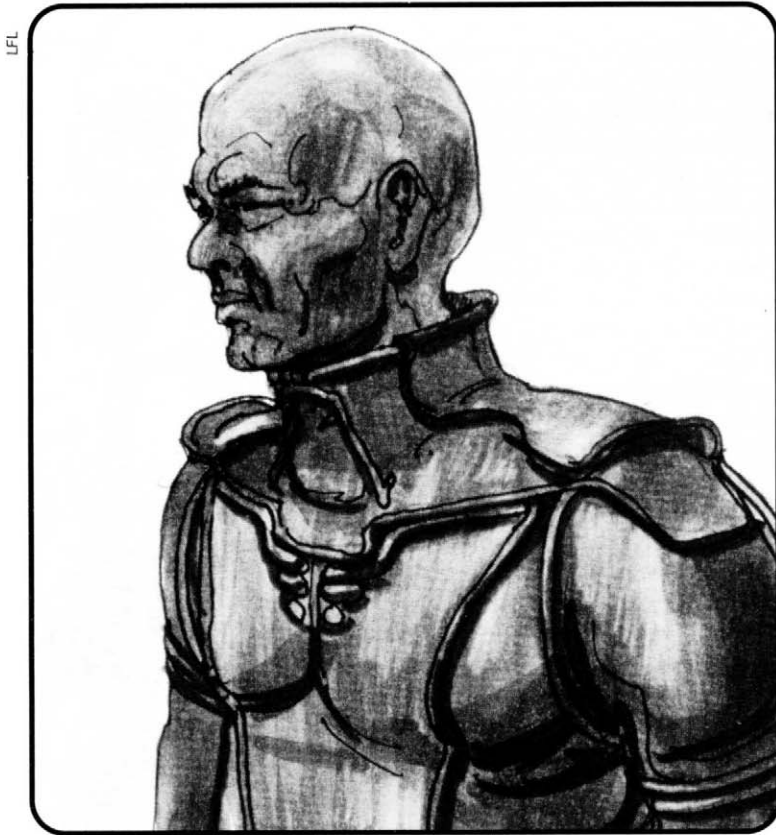

■ Coral Ohah of Sleaf Docking Bay Maintenance

ward hold, they learn that the cargo was a shipment of power fusion crystal chips, used to regulate fusion generators. Removing the chips will be quick and safe, and perhaps there is even a chance for the characters to make amends with their rivals. In addition, Notsub will give a 500 credit bonus to each group which helped unload the chips.

The Edge of Fashion

A friend of the characters, Kieth Cairn, has disappeared after a medical visit to the Cutting Edge clinic. It seems that Doctor Cornelius has slipped up once too often.

Episode One: A friend of the characters named Kieth Cairn calls on them while he is in port. He wants to meet them to discuss a new contract, family business or some other plausible explanation. He explains that he has some things to do before the meeting, including a stop at the Jawa Traders Droid shop, but after that he will meet them. However, he doesn't appear.

The characters will probably turn suspicious and investigate Jawa Traders. There, they will encounter the Squib and Jawa owners of the shop. While the characters are there, Dr. Cornelius will stop by to pick up a few "Droid" parts that will be used for his evil cyborging experiments.

The Doctor will mention to the Jawa that the "messenger" he sent by yesterday was "delightful." If the characters ask, the Jawa will seem evasive about the situation — ultimately, by asking around the city, perhaps street people, shop owners and so forth, they will learn that Kieth was the messenger (he agreed to drop off some parts in order to save a few credits on the deal — it was the Squib's idea). What neither Kieth nor the Squib knew was that Dr. Cornelius would somehow subdue him and perform experiments on him, burying the body in the caves below Mos Eisley.

Episode Two: Eventually the characters learn Dr. Cornelius' street address, and will presumably decide to investigate (the city police have no interest in the case since Kieth wasn't a Tatooine resident).

If the characters come during normal office hours, the receptionist is able to figure out what they were up to, and will only allow them to make an appointment for the next day. If they leave an address, the place they are staying at will be ransacked at some point in the adventure. It is suggested that the group return after hours to investigate. The office shows signs of recent activities: there are stains on smocks and the tools have not been cleaned.

The medical files on the computer relate sto-



■ The infamous Dr. Evazan/Cornelius

Mike Manley

ries of horror. Files have many personal notes scattered throughout, telling how Cornelius disposed of bodies and other gruesome details. The characters can easily find the file dealing with the death of Kieth.

A medical Droid is sitting in a corner, seemingly deactivated. But it suddenly comes to life and begins prepping for an operation. Taking a closer look, it is obvious that the Droid's olfactory and visual electronics have been ripped out of its head, but it is ready to go after the characters.

Episode Three: The characters have discovered the gruesome truth — what they want to do about the goings-on is their business. The police, upon hearing proof, will opt to investigate. Meanwhile, Dr. Cornelius will attempt to hunt them down — a night-time fight in the alleys of Mos Eisley would make a suitable dramatic conclusion. For added suspense, Ponda Baba, Dr. Cornelius' former Aqualish companion, confronts the doctor in the interest of revenge.

A Bith Saved Is A Bith Learned

A Sleeft Docking Bay Maintenance freighter was checked out by a Bith named Angor Farn. He accidentally got the wrong ship: the cargo is a load of high-quality Droid parts, stolen from one of Armanda Durkin's warehouses by Sleeft. While Sleeft hired Angor to take a cargo of power converters to the Corellian system, he hit the jackpot with this load of Droid parts. Angor Farn has not only found the parts, but has decided to skip town with them.

To do that, he needs to change the transponder signal. Thus, he is visiting the Dim-U monastery. The Sleeft company knows where he went, but not why (they are unaware of the monastery's true nature). Angor has contacted Armanda with an offer to sell the Droid parts in order to get some liquid credits. Armanda suspects that Angor is trying to sell back her own cargo. Angor's ship is stationed at Docking Bay 31 while he waits for the new transponder code or the money from Armanda. Armanda is playing the scene cautiously because she knows that she can't openly buy the parts from Angor without alerting Sleeft that she is involved in piracy and purchasing black market parts. Armanda also wants to find proof that Sleeft is responsible for these actions

against her.

Episode One: Coral Ohah, one of the directors of Sleeft Docking Bay Maintenance, contacts the characters. Coral tells them a high-level corporate partner of Sleeft has been kidnapped, a Bith named Angor Farn. Because of the nonviolent, pacifistic nature of Biths, he clearly will not attempt to escape — and might actually impede his own rescue in the hopes of working out an equitable and peaceful arrangement. Nevertheless, he is in possession of information which must not fall into the hands of competitors. Coral hints that the competition is notorious for their brainwashing and interrogation techniques.

He is being held at the Dim-U Monastery, possibly without the monastery's knowledge. So Coral wants to hire the characters to infiltrate and comb the place for Angor. Coral will go in with them.

Episode Two: The characters can pose as Bantha purchasers, new converts or perhaps fellow ecology buffs devoted to saving the natural habitat of the Bantha — whatever gets them access to the monastery. Once inside, the characters can split up and wander around, while Coral approaches the abbot. The characters soon discover that there is more to the Dim-U than meets the eye, but soon Coral reappears and herds everyone out. Clearly an assault is warranted: Angor is inside, but will soon be moving. Time is of the essence.

Episode Three: Coral wants to attack an hour later. Depending upon the characters' tactics, the monks and nuns may defend, or simply flee. Drayk destroys the database if it appears to be in jeopardy and takes off. Coral finds Angor, and the characters carry him out. Coral privately debriefs Angor. He learns of the Bith's attempted betrayal, and finds out where the freighter is docked. He also learns that Armanda's security guards are preparing to confiscate the ship since Drayk has probably informed Notsub what Coral has done.

Coral returns to the characters, pays them, and offers another story and another job proposal: the ship is being guarded by the "riff-raff" who originally kidnapped the Bith, and the ship must be retrieved before the valuable cargo can be sold. Of course, the ship is actually being

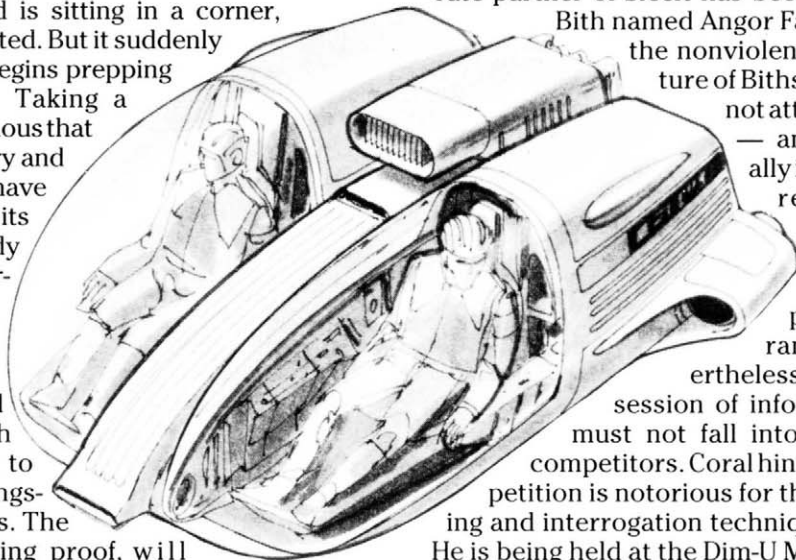

guarded by undercover Notsub guards (Armanda requires undercover guards so she can hide her involvement in this caper). The freighter is about to leave, so the characters must blast into the bay and take off, landing at specific coordinates far to the south of Mos Eisley. They will be met by a squad of Sleet security, who will pay them and take the ship; they will be given a private transport so they can sneak back into Mos Eisley unnoticed.

Episode Four: Unaccompanied by Coral, but with Angor, the characters break into the bay,

but have to fight through the small guard complement and take off without clearance.

Once the craft is airborne, they are attacked by a pair of Mos Eisley's cloud cars, and then after they are fended off, a pair of Notsub Z-95 Headhunters take to the air after them. The characters are likely outgunned and outclassed. Once they are forced down, Angor explains to the characters and Armanda what really happened. Armanda declares that she will take the Droid parts, and the ship as payment. But she offers the characters a cargo run or some other job as a way to repay the deceptions of Coral.

The Saga Continues!

DARK FORCE RISING

S O U R C E B O O K



RR 3 Box 2345 ■ Honesdale, PA 18431

® , ™ & © 1993 Lucasfilm, Ltd. (LFL). All Rights Reserved. Trademarks of LFL used by West End Games under authorization.

SPACE IS BIG. LIFE IS HARD.

On the Frontier. Beyond the Core.

There is Jonn Stryker,
a leader of men, a mercenary without peer,
who fought for power, glory and money.

Until he became the

SOLE SURVIVOR

...and you're happy about it either.

It began with **THE RIVER OF GOD**,
it continues with **SOLE SURVIVOR**.

**West End Games has recreated the universe.
In the Summer of 1993, so will you.**

SHATTERZONE™



®, TM & © 1993 West End Games. All Rights Reserved.

STAR WARS®

GALAXY GUIDE 7 MOS EISLEY

by Martin Wixted

Come explore the infamous pirate spaceport city of Mos Eisley. Pounded by the relentless twin suns of Tatooine, Mos Eisley is host to some of the most famous (or infamous) smugglers and criminals in the galaxy!

Made famous by the exploits of Han Solo and the treachery of Jabba the Hutt, Mos Eisley is the ultimate adventuring locale for fans of the *Star Wars* movies.

This book provides a complete overview of this outlaw city. It contains detailed location descriptions, with maps, gamemaster character descriptions and illustrations. Includes introductory chapters describing the history of Tatooine and Mos Eisley!

A STAR WARS® SUPPLEMENT

For gamemaster and one or more players.
For ages 12 and up.

®, ™ & © 1993 Lucasfilm, Ltd. (LFL). All Rights Reserved.
Trademarks of LFL used by West End Games under authorization.



40069



STAR WARS®

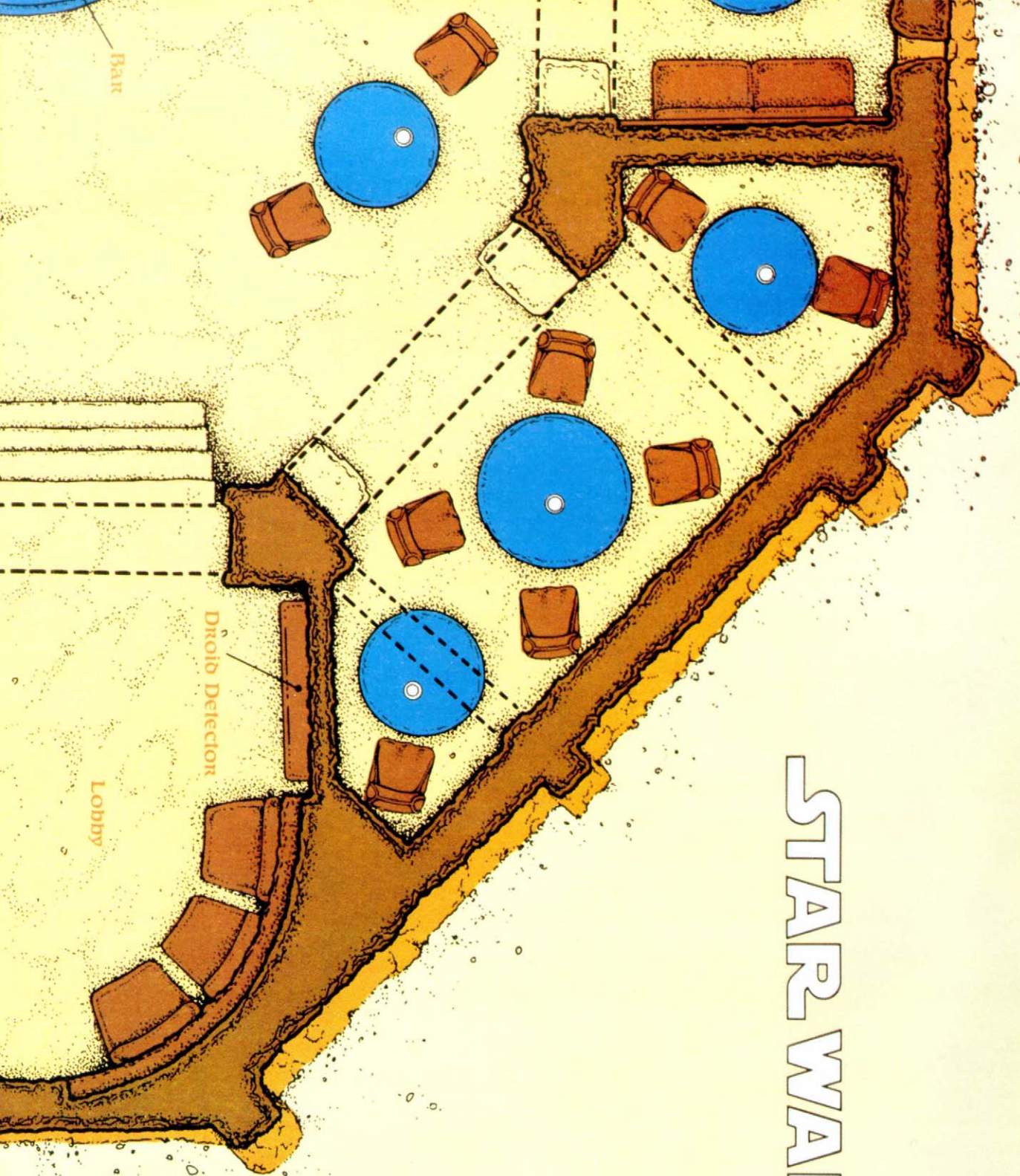

Bar

Droid Detector

Lobby

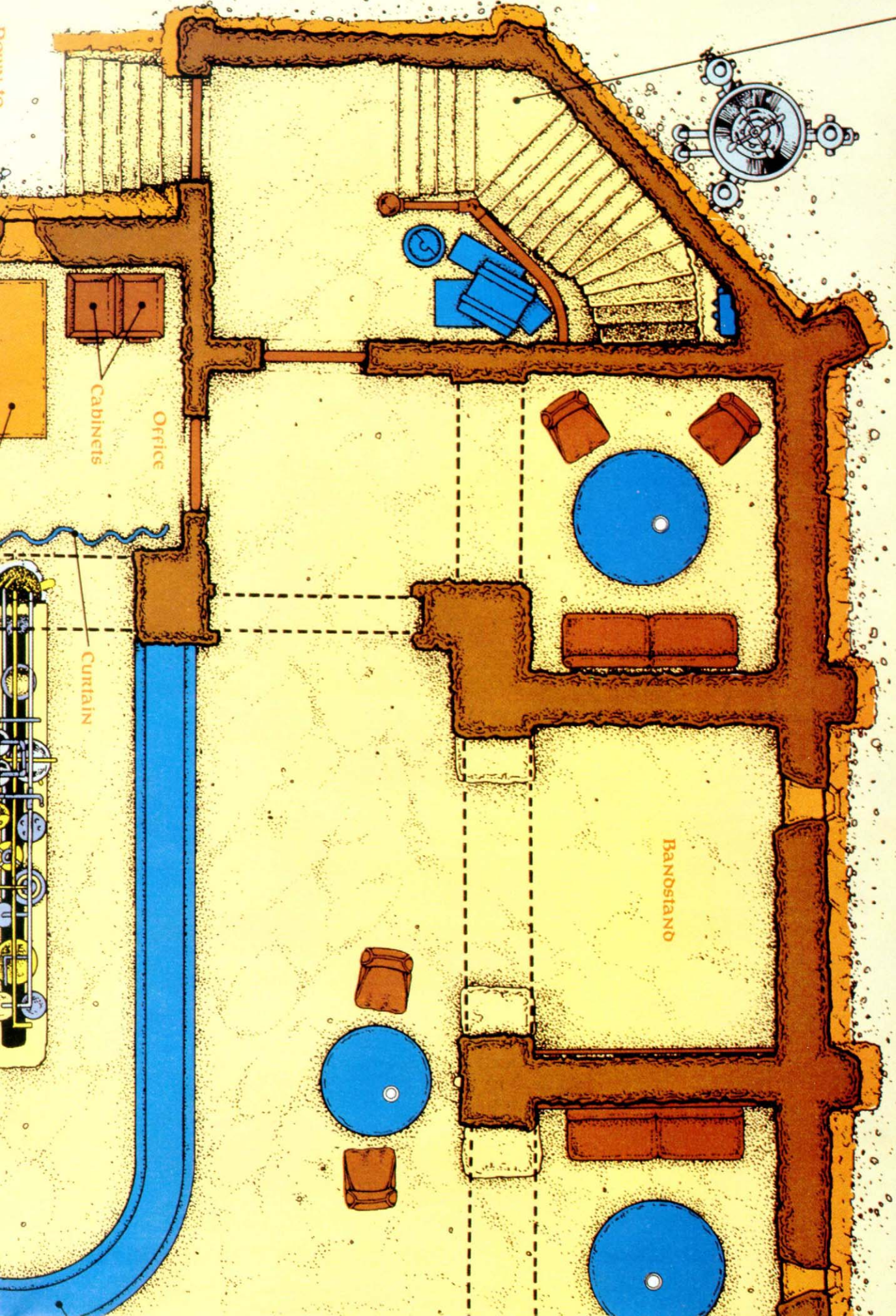

BANDSTAND

Office

Cabinets

Curtain

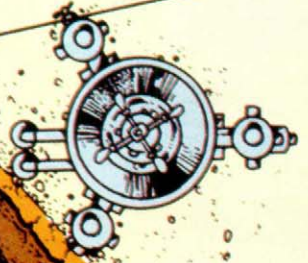

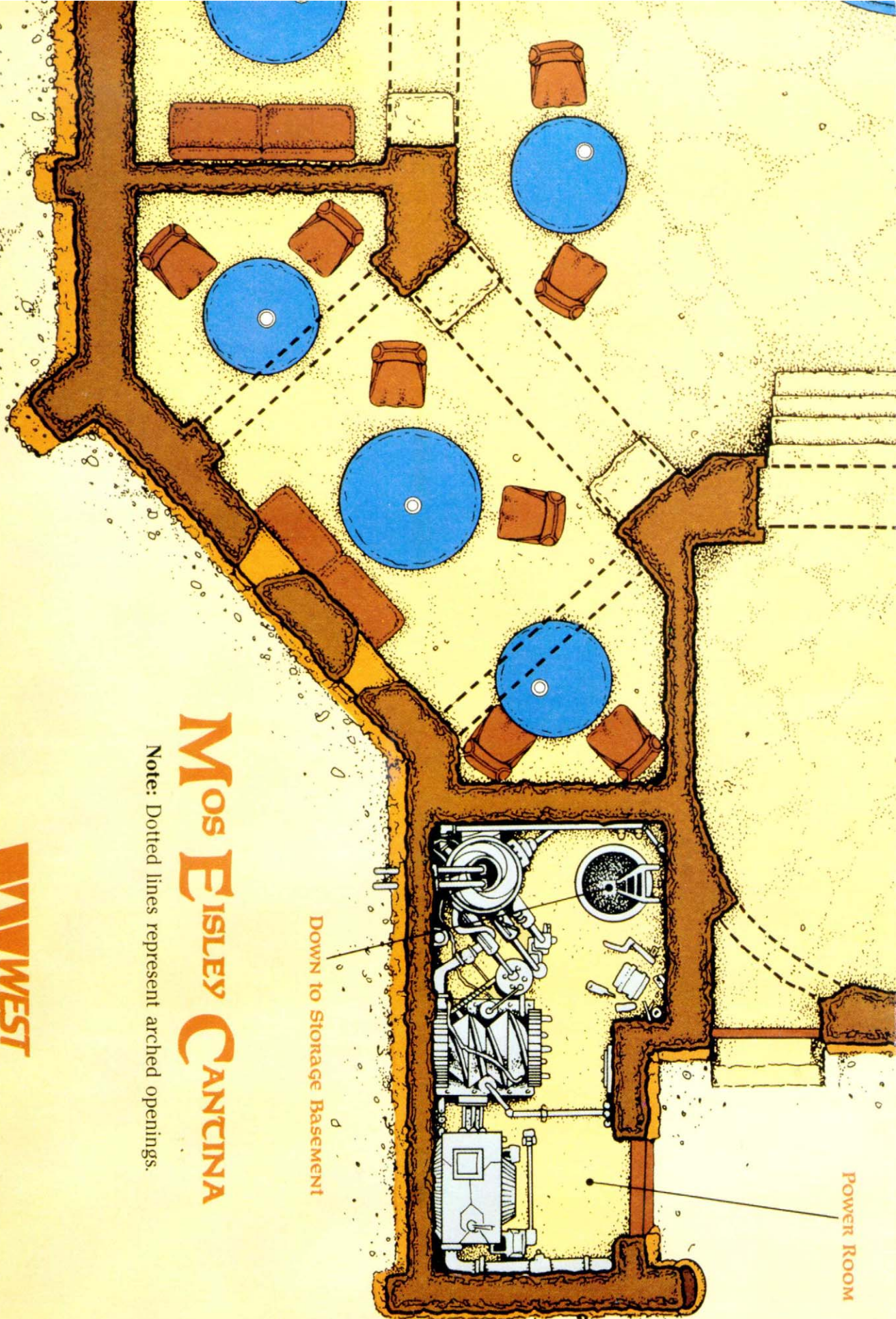

POWER ROOM

DOWN TO Storage Basement

Mos Eisley Cantina

Note: Dotted lines represent arched openings.



Storage
Basement

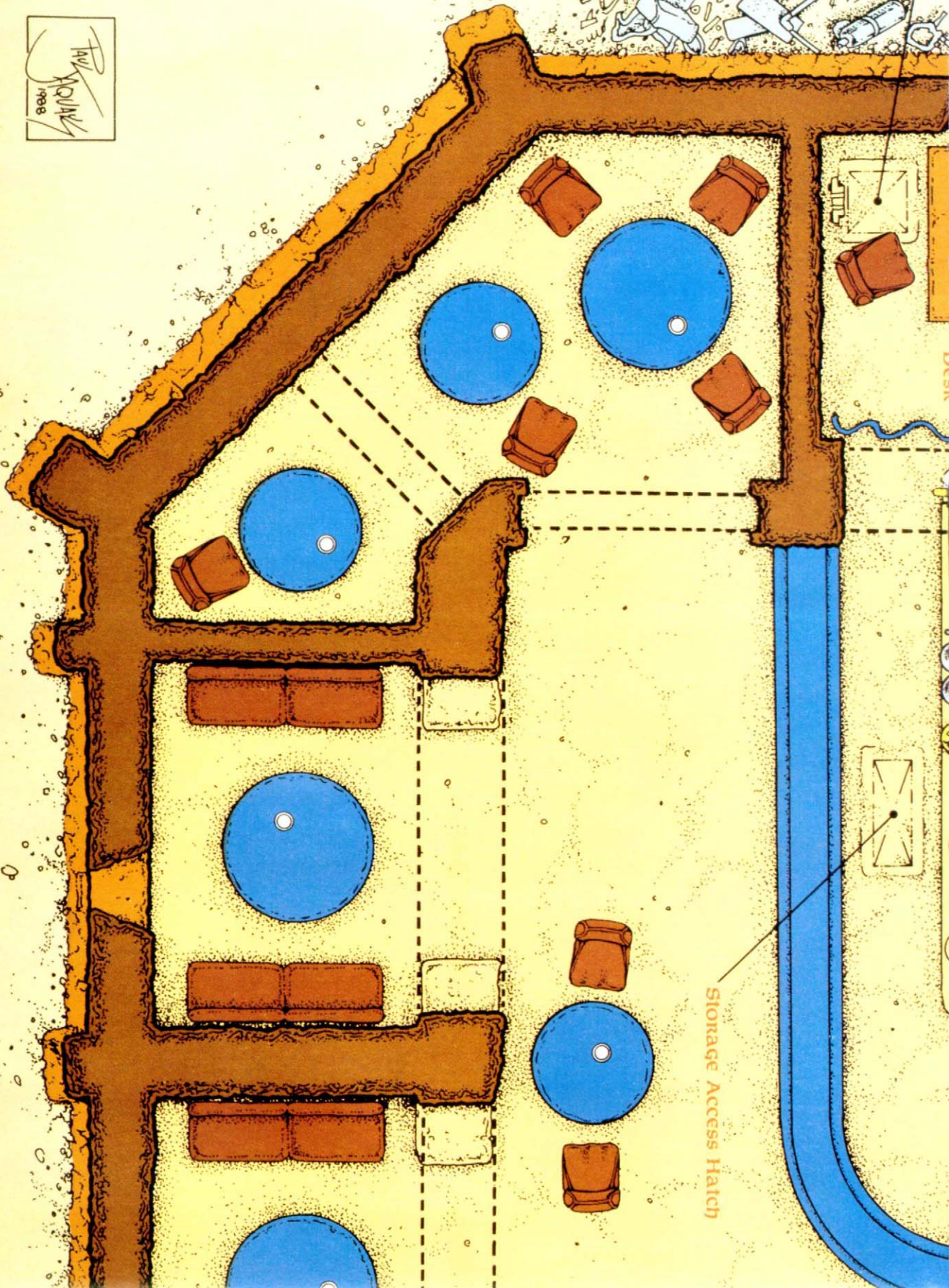

TAV
1998

Storage Access Hatch





-
1. Docking Bay 94
 2. Spaceport Customs
 3. Spaceport Speeders
 4. Lup's General Store
 5. Market Place
 6. Docking Bay 86
 7. Docking Bay 87
 8. Mos Eisley Inn
 9. Tatooine Militia
 10. Dewback Stables
 11. Regional Government Offices
 12. Power Station
 13. Jabba's Townhouse
 14. Street Corner Preacher
 15. Wreckage
 16. Mos Eisley Cantina
 17. Jawa Traders
 18. Heff's Souvenirs
 19. Kayson's Weapon Shop
 20. Dockside Cafe
 21. Docking Bay 92
 22. Spaceport Hotel Complex

Mos Eisley

Central Sector



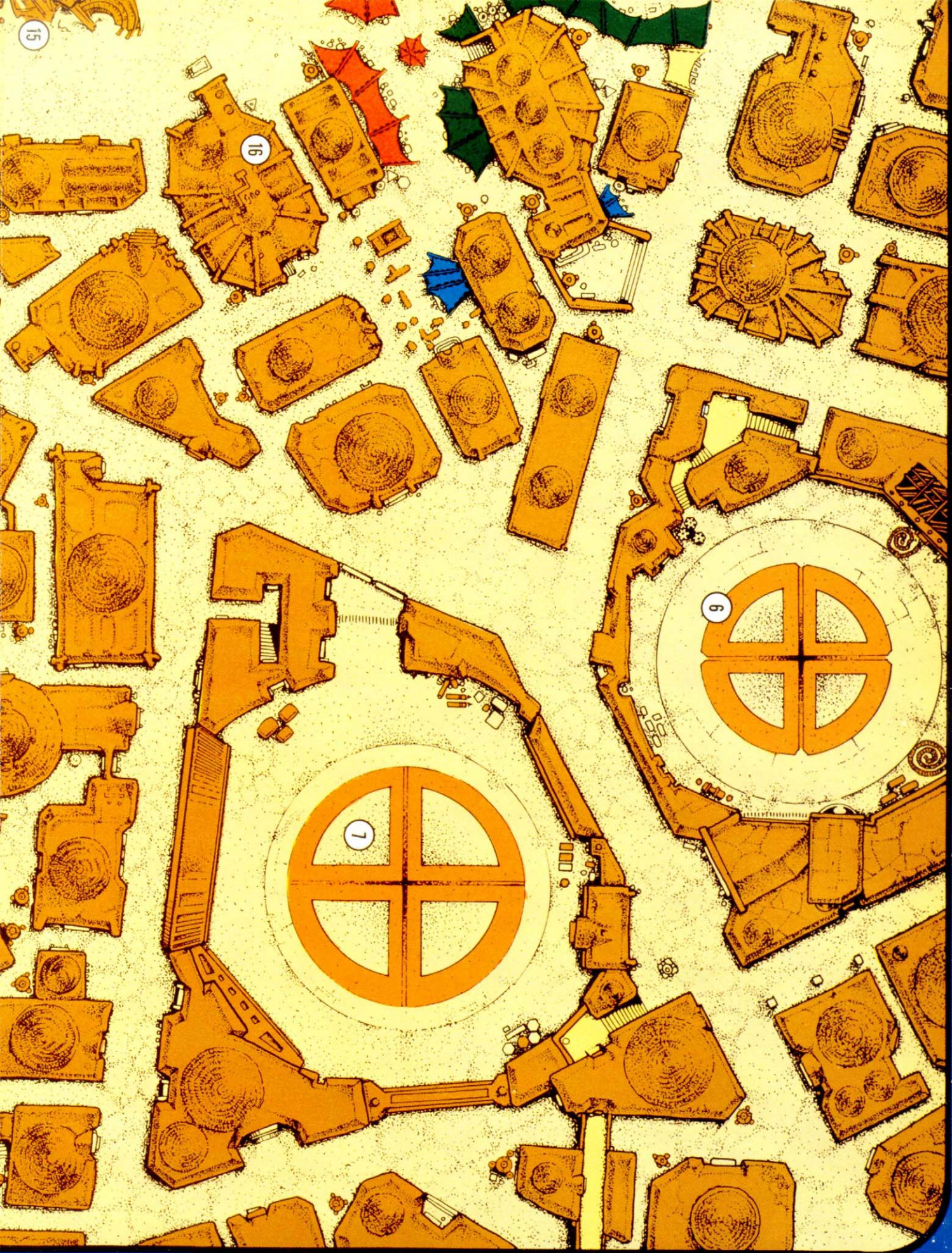

15

16

8

7

STAR WARS[®]

MOS EISLEY

Adventure Set

"Mos Eisley Spaceport. You'll never find a more wretched hive of scum and villainy."

It's a city teeming with danger, filled with shadowy characters who have their own hidden agendas. Smugglers and gangsters wander the streets, while illicit cargoes trade hands in the back corners of docking bays and cantinas.

This desert spaceport city is the ultimate adventuring locale for fans of the *Star Wars* movies. This boxed set is a guide to the hazards and opportunities to be found in Mos Eisley, with numerous adventures, characters and locations for players to explore.

"Only watch your step. This place can be a little rough."

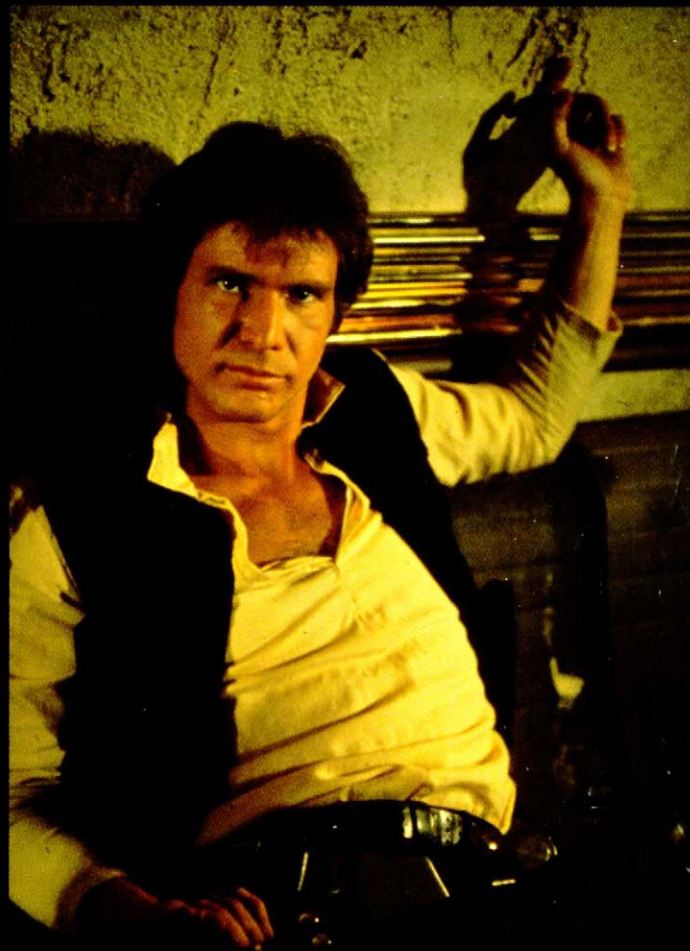

THIS BOXED SET CONTAINS:

- 12 metal miniatures suitable for painting and gaming.
- A 32-page adventure book feature roleplaying adventures.
- *Galaxy Guide 7: Mos Eisley*.
- A full-color map. One side depicts the infamous Mos Eisley Cantina, while the other side features downtown Mos Eisley, including the Cantina, Docking Bay 94 and Jabba the Hutt's Townhouse.
- Six-sided dice.

A STAR WARS[®]

ADVENTURE SUPPLEMENT

For use with the *Star Wars* roleplaying game
and *Star Wars Miniatures Battles*.

